

THIS DRAWING AND SPECIFICATIONS, HEREIN, ARE THE PROPERTY OF INVENTEC CORPORATION AND SHALL NOT BE REPRODUCED, COPIED, OR USED IN WHOLE OR IN PART AS THE BASIS FOR THE MANUFACTURE OR SALE OF ITEMS WITHOUT WRITTEN PERMISSION, INVENTEC CORPORATION, ©2018 ALL RIGHT RESERVED.

NOTES:
1.HSF Property:Comply iSupplier system HSF property attribute up-to-date value.

TENJIN

MV BUILD

2019.5.17

DATE	CHANGE NO.	REV
21-OCT-2002		

DESIGN/DRAWER		XXX	DATE		21-OCT-2002	TITLE		MODEL PROJECT,FUNCTION		
CHECK		EVAN SHIH	SIZE		A3	CODE		MAIN BOARD		
APPROVAL		MORRIS CHANG	PCB PIN		XXXXXXXXXX	PCB VER		XXX		
FILE NAME		TENJIN (20190517) (2) (1).dxf	SHEET		1 of 66	DOC NUMBER		1.310XXXXXXXX-0		
REV			REV		X01	SHEET		1 of 66		

INVENTEC

700 System Block Diagram

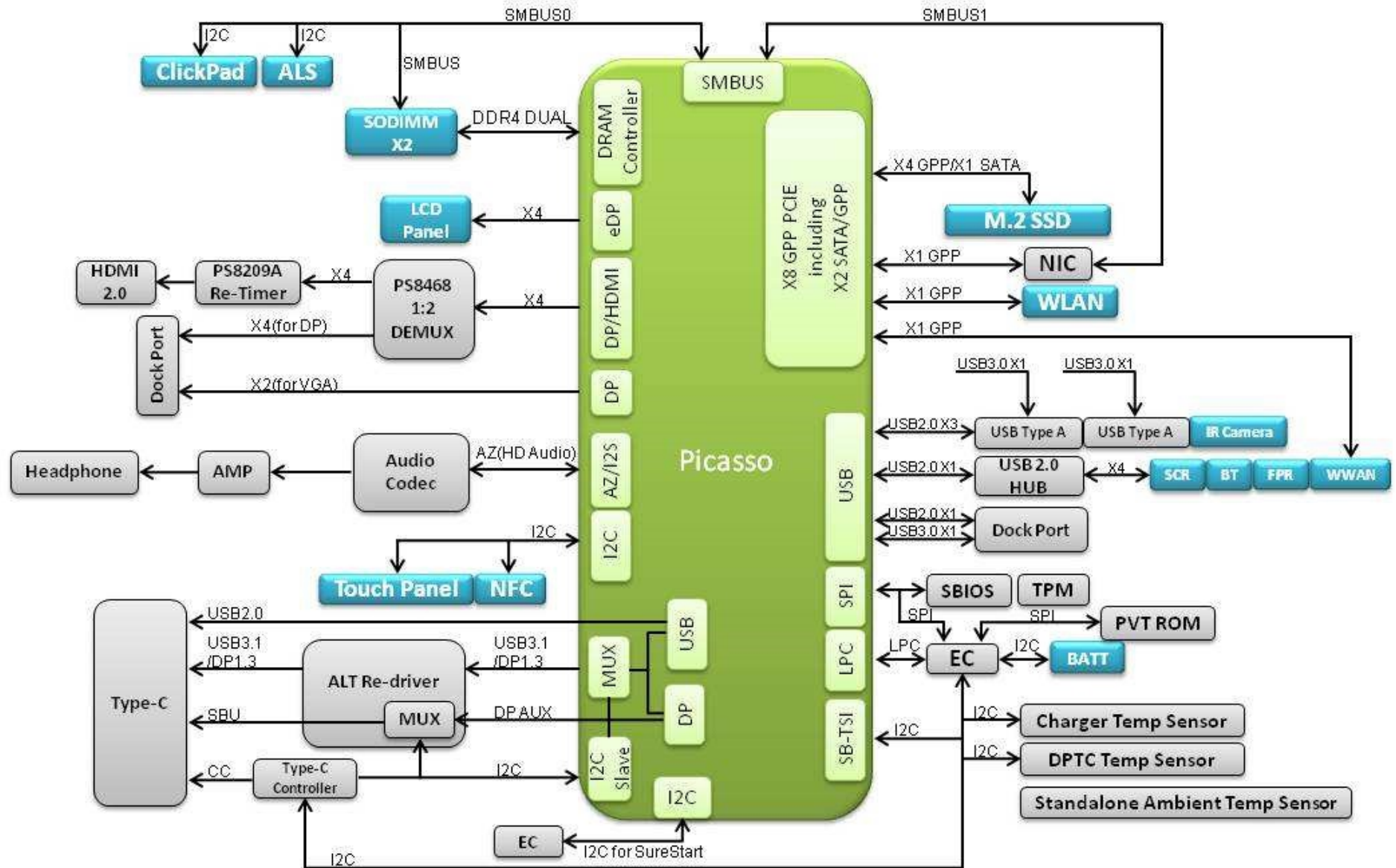

TITLE			
MODEL,PROJECT,FUNCTION			
Block Diagram			
SIZE	CODE	DOC NUMBER	REV
A3	CS	1310xxxxx-0-0	X01
SHEET			REV
1			X01

CHANGE# xxx PCBPN 6Dxxxxxxxxx DATE 21-OCT-2002 PCBVER xxx

TABLE OF CONTENTS

01.PROJECT NAME	30.APU FP5-7	58.POWER BUTTON LED
02.BLOCK DIAGRAM	31.APU FP5-8	59.SMART CARD D/B
03.TABLE OF CONTENTS	32.APU FP5-9	60.SMART CARD LED
04.PROJECT DESIGN INFO.	33.DDR4_SO-DIMM0	61.USB D/B-1
05.BLOCK DIAGRAM_POWER	34.DDR4_SO-DIMM1	62.USB D/B-2
06.SEQUENCE	35.DP DEMUX	63.ALS D/B
07.I2C/SMBUS MAP	36.HDMI CNTR	64.MIC D/B
08.SYSTEM POWER(CHARGER)	37.EDP & WEBCAM	65.SCREW
09.SYSTEM POWER(BARREL/PD SELECTOR)	38.M.2 SSD CNTR	66.EMI & RF SOLUTION
10.SYSTEM POWER(ADP_ID/OCP)	39.USB 2.0 HUB & USB 3.0 RE-DRIVER	
11.SYSTEM POWER(P5V0DS)	40.USB WALK UP0	
12.SYSTEM POWER(P3V3DS)	41.USB-C PD CONTROLLER	
13.SYSTEM POWER(P1V2)	42.USB-C REDRIVER	
14.SYSTEM POWER(P2V5)	43.USB-C CNTR	
15.SYSTEM POWER(P0V9A)	44.FP & PS & NFC CNTR	
16.SYSTEM POWER(P1V8A)	45.BIOS	
17.VCORE CONTROLLER	46.KBC	
18.SYSTEM POWER(VCORE & VCORE_NB)	47.KEYBOARD	
19.NA	48.TPM	
20.DC JACK & BATTERT CNTR.	49.LAN NIC	
21.POWER(SLEEP)	50.TRANSFORMER & RJ45	
22.POWER(SEQUENCE)	51.M.2 WLAN & BT	
23.FAN & THERMAL	52.M.2 WWAN	
24.APU FP5-1	53.DOCK CONNECTOR	
25.APU FP5-2	54.AUDIO CODEC	
26.APU FP5-3	55.SPEAKER & AUDIO JACK	
27.APU FP5-4	56.D/B CNTR & 12S SHUT DOWN	
28.APU FP5-5	57.POWER BUTTON D/B	
29.APU FP5-6		

INVENTEC

TITLE MODEL PROJECT FUNCTION
TABLE OF CONTENTS

SIZE A3	CODE CS	DOC NUMBER 1310xxxxx-0-0	REV X01
SHEET		3 of 66	

CHANGE by	XXX	DATE	21-OCT-2002
PCB P/N	60xxxxxxxxxx	PCB VER	XXX

SIGNAL	VOTAGE	G3	S5	S3	S0	REMARK
P1V5A_RTC	1.5V	O	O	O	O	COIN BATTERY
PVBAT	19V	X	O	O	O	DC-IN ALWAYS
P3V3DS	3.3V	X	O	O	O	DC-IN ALWAYS
P5V0DS	5V	X	O	O	O	DC-IN ALWAYS
P3V3A	3.3V	X	O	O	O	
P1V8A	1.8V	X	O	O	O	
P0V9A	0.9V	X	O	O	O	
P2V5	2.5V	X	X	O	O	
P5V0A_USB	5V	X	X	O	O	
P1V2	1.2V	X	X	O	O	
P5V0S	5V	X	X	X	O	
P3V3S	3.3V	X	X	X	O	
P1V8S	1.8V	X	X	X	O	
P0V9S	0.9V	X	X	X	O	
P0V6S	0.6V	X	X	X	O	
PVCORE_NB	SVC/SVD	X	X	X	O	
PVCORE	SVC/SVD	X	X	X	O	

INTERFACE	PORT ASSIGNMENT
USBC/DP#0	USB TYPE-C
USBC/DP#1	NA
USB3_0#1	WALK UP PORT0
USB3_0#2	WALK UP PORT1
USB3_1#0	DOCK PORT
GPP0	WWAN
GPP1	NIC
GPP2	WLAN
GPP3	NA
GPP4	M.2 SSD
GPP5	M.2 SSD
GPP6	M.2 SSD
GPP7	M.2 SSD
DDI0	EDP
DDI1	HDMI / DOCK PORT
DDI2	DOCK PORT VGA
SATA0	NA
SATA1	M.2 SSD

USB 2.0	PORT ASSIGNMENT
USB2_0#0	USB TYPE-C
USB2_0#1	WALK UP PORT0
USB2_0#2	WALK UP PORT1
USB2_0#3	DOCK PORT
USB2_1#0	USB2.0 HUB
USB2_1#1	CAMERA

INVENTEC

TITLE: MODEL, PROJECT, FUNCTION
Block Diagram

SIZE A3 CODE CS DOC NUMBER 1310xxxx-0-0 REV X01

CHANGE by: XXX DATE: 21-OCT-2002
PCB P/N: 60xxxxxxxxxxx PCB VER: XXX

SHEET 4 of 66

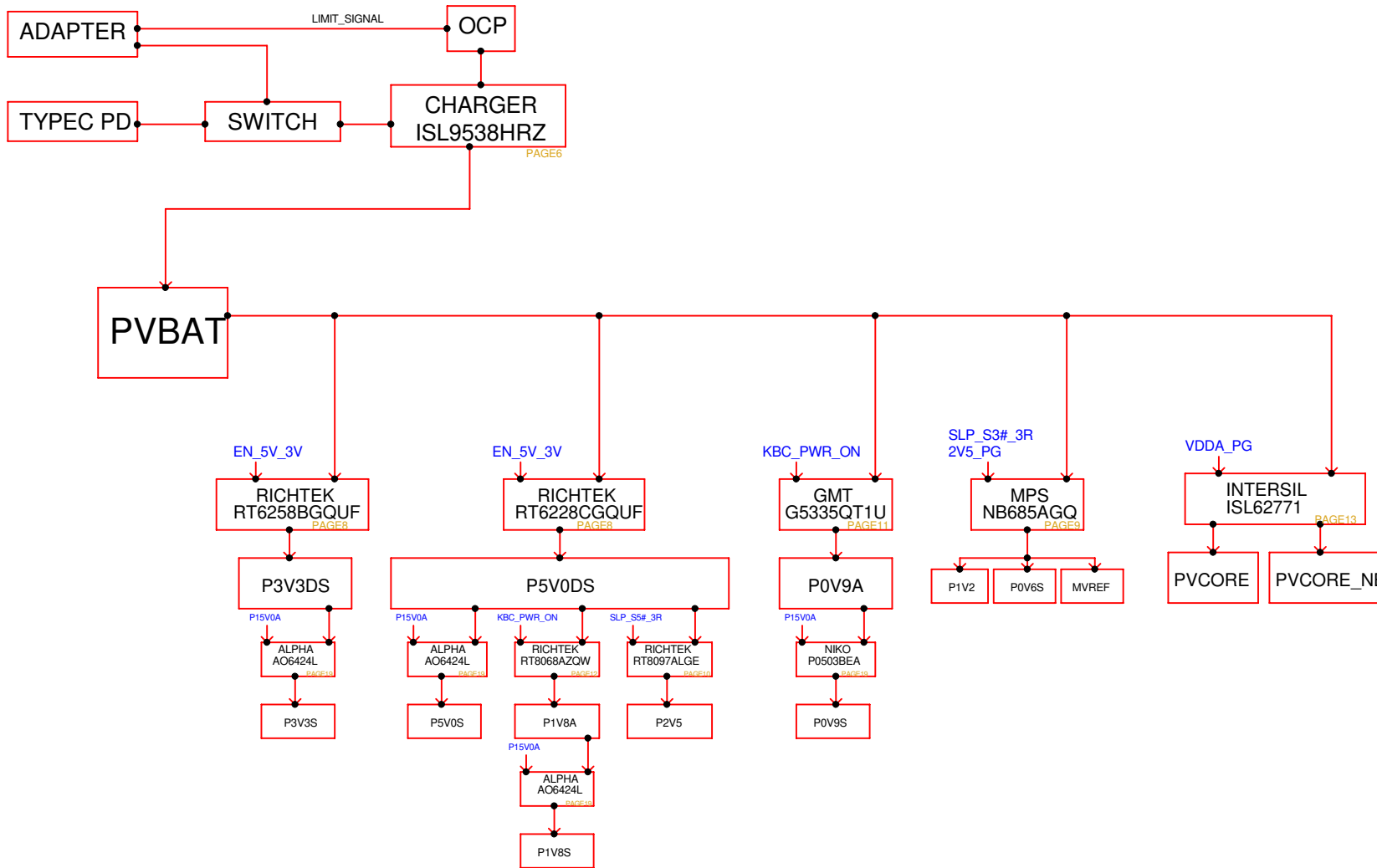

INVENTEC

TITLE			
MODEL PROJECT FUNCTION BLOCK DIAGRAM POWER			
SIZE A3	CODE CS	DOC NUMBER 1310xxxxx-0-0	REV X01
SHEET		5 of 66	

CHANGE by	XXX	DATE	21-OCT-2002
PCB P/N	60xxxxxxxxxx	PCB VER	XXX

D
C
B
A

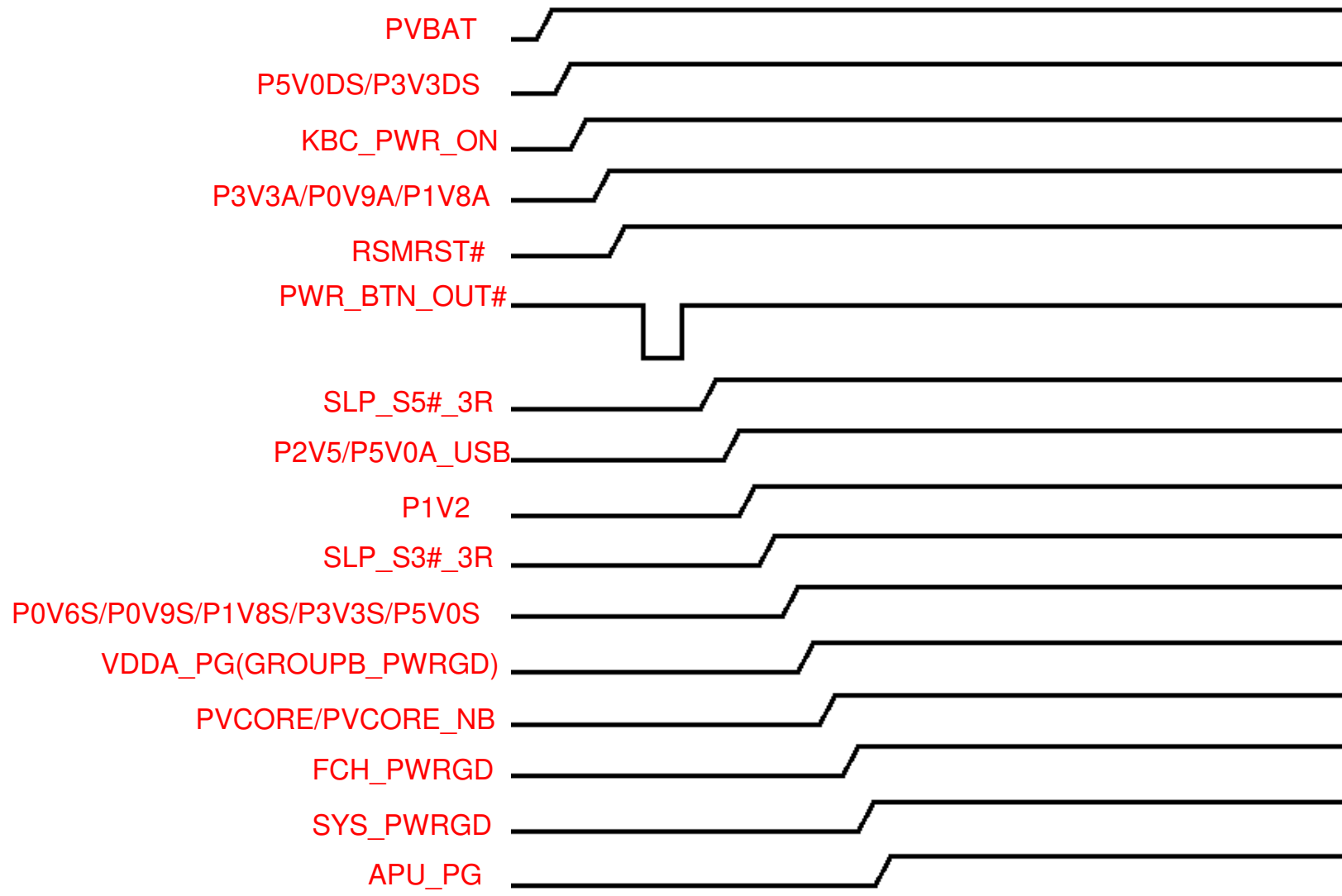

INVENTEC

TITLE			
MODEL,PROJECT,FUNCTION SEQUENCE			
SIZE A3	CODE CS	DOC.NUMBER 1310xxxx-0-0	REV X01
SHEET 6 of 66			

CHANGE by	XXX	DATE	21-OCT-2002
PCB P/N	60xxxxxxxxxx	PCB VER	XXX

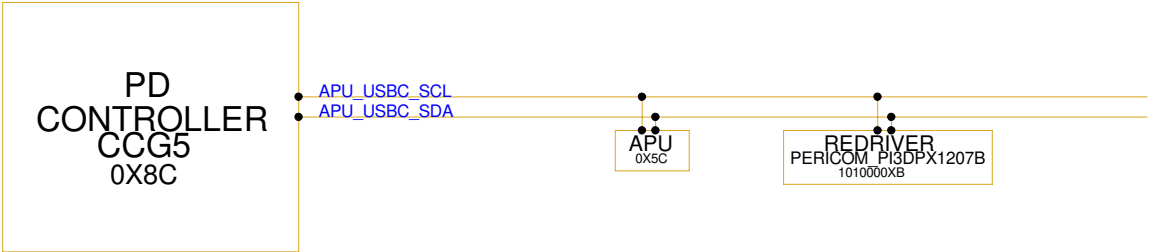
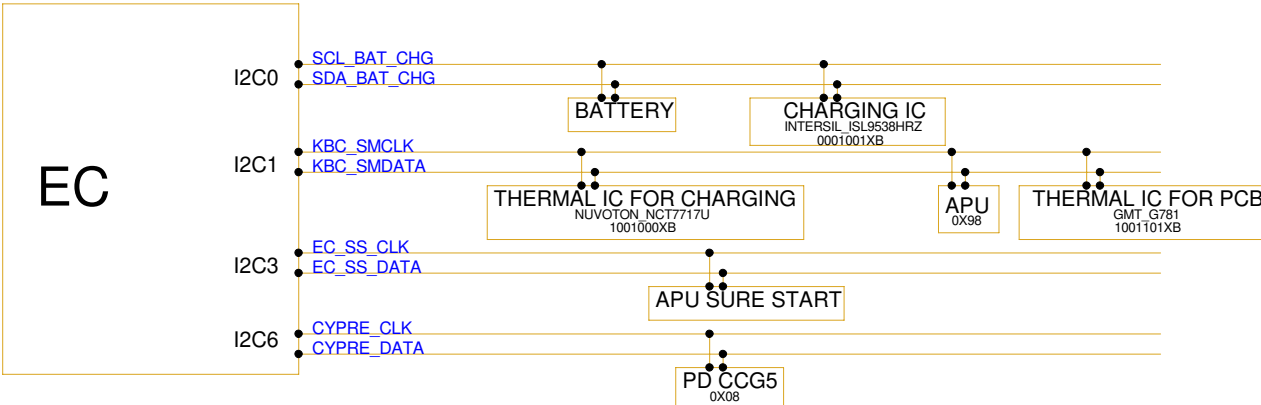
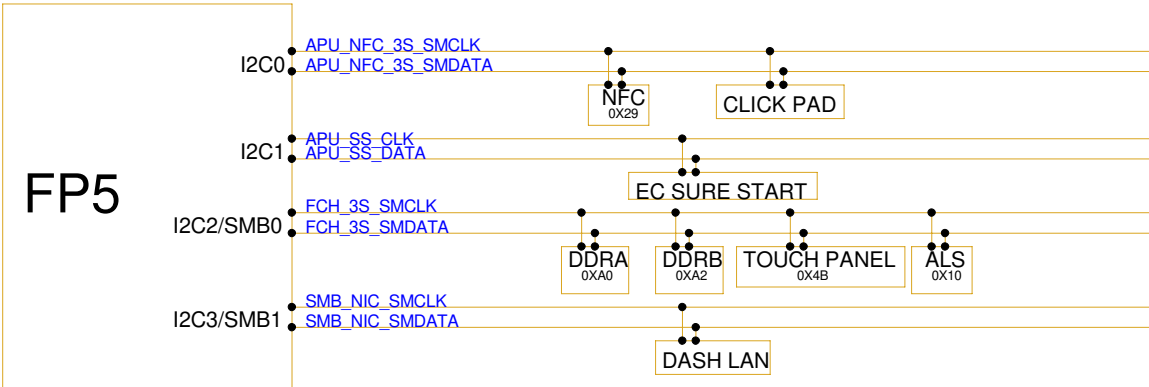

INVENTEC			
TITLE MODEL,PROJECT,FUNCTION Block Diagram			
SIZE A3	CODE CS	DOC NUMBER 1310XXXX-0-0	REV X01
CHANGE by XXX		DATE 21-OCT-2002	
PCB P/N 60XXXXXXXXXX		PCB VER XXX	
SHEET 7 of 66			

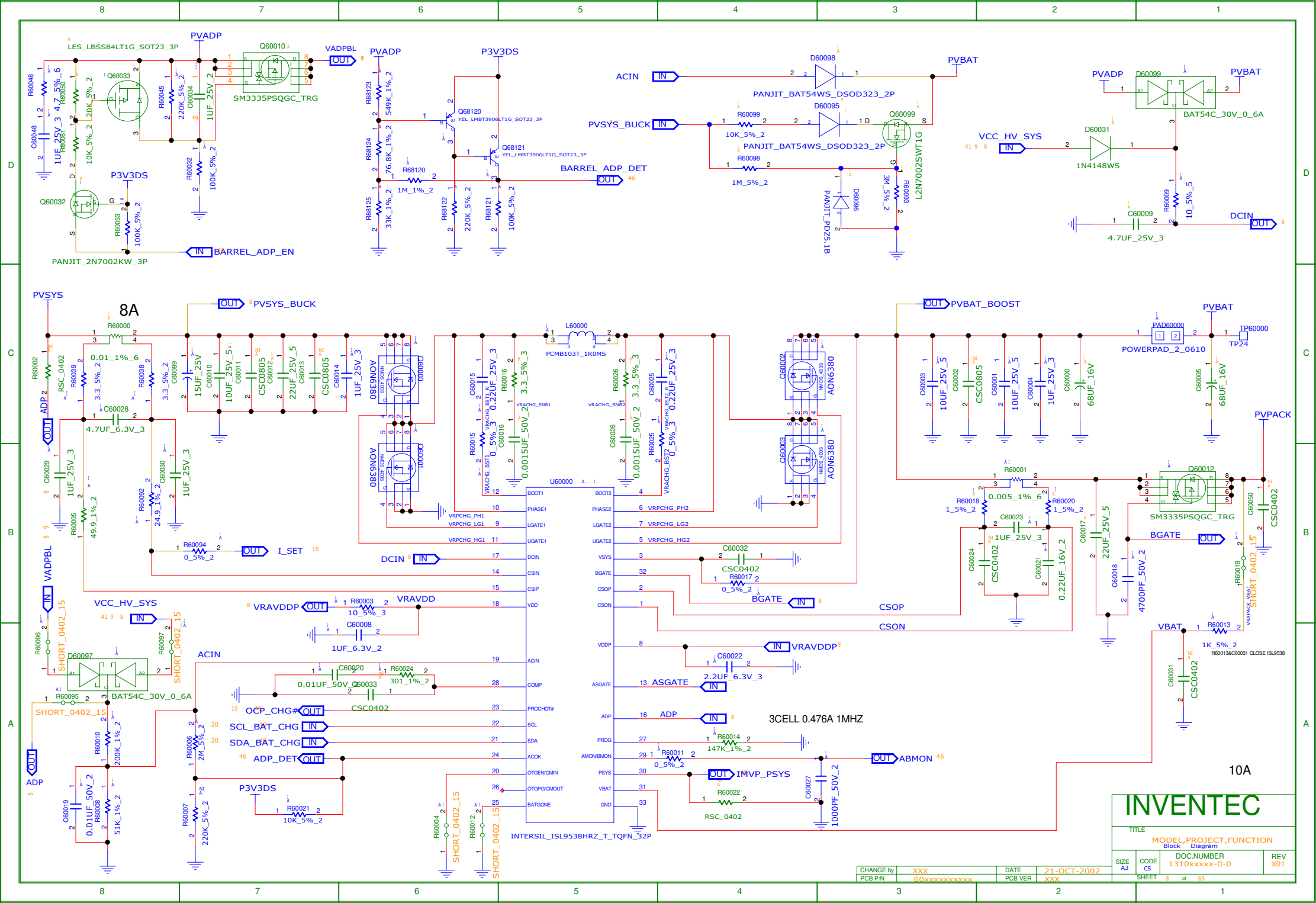

INVENTEC

TITLE			
MODEL,PROJECT,FUNCTION			
Block Diagram			
SIZE	CODE	DOC NUMBER	REV
A3	CS	1310xxxx-0-0	X01
SHEET		8 of 66	

CHANGE by	XXX	DATE	21-OCT-2002
PCB P/N	60xxxxxxxxxxx	PCB VER	XXX

10A

3CELL 0.476A 1MHZ

INTERSIL_ISL9538HRZ_T_TQFN_32P

SM3335PSQGC_TRG

PANJIT_2N7002KW_3P

SM3335PSQGC_TRG

LES_LBSS84LT1G_SOT23_3P

Q60010

Q60032

Q60033

Q60034

Q60035

Q60036

Q60037

Q60038

Q60039

Q60040

Q60041

Q60042

Q60043

Q60044

Q60045

Q60046

Q60047

Q60048

Q60049

Q60050

Q60051

Q60052

Q60053

Q60054

Q60055

Q60056

Q60057

Q60058

Q60059

Q60060

Q60061

Q60062

Q60063

Q60064

Q60065

Q60066

Q60067

Q60068

Q60069

Q60070

Q60071

Q60072

Q60073

Q60074

Q60075

Q60076

Q60077

Q60078

Q60079

Q60080

Q60081

Q60082

Q60083

Q60084

Q60085

Q60086

Q60087

Q60088

Q60089

Q60090

Q60091

Q60092

Q60093

Q60094

Q60095

Q60096

Q60097

Q60098

Q60099

Q60100

Q60101

Q60102

Q60103

Q60104

Q60105

Q60106

Q60107

Q60108

Q60109

Q60110

Q60111

Q60112

Q60113

Q60114

Q60115

Q60116

Q60117

Q60118

Q60119

Q60120

Q60121

Q60122

Q60123

Q60124

Q60125

Q60126

Q60127

Q60128

Q60129

Q60130

Q60131

Q60132

Q60133

Q60134

Q60135

Q60136

Q60137

Q60138

Q60139

Q60140

Q60141

Q60142

Q60143

Q60144

Q60145

Q60146

Q60147

Q60148

Q60149

Q60150

Q60151

Q60152

Q60153

Q60154

Q60155

Q60156

Q60157

Q60158

Q60159

Q60160

Q60161

Q60162

Q60163

Q60164

Q60165

Q60166

Q60167

Q60168

Q60169

Q60170

Q60171

Q60172

Q60173

Q60174

Q60175

Q60176

Q60177

Q60178

Q60179

Q60180

Q60181

Q60182

Q60183

Q60184

Q60185

Q60186

Q60187

Q60188

Q60189

Q60190

Q60191

Q60192

Q60193

Q60194

Q60195

Q60196

Q60197

Q60198

Q60199

Q60200

Q60201

Q60202

Q60203

Q60204

Q60205

Q60206

Q60207

Q60208

Q60209

Q60210

Q60211

Q60212

Q60213

Q60214

Q60215

Q60216

Q60217

Q60218

Q60219

Q60220

Q60221

Q60222

Q60223

Q60224

Q60225

Q60226

Q60227

Q60228

Q60229

Q60230

Q60231

Q60232

Q60233

Q60234

Q60235

Q60236

Q60237

Q60238

Q60239

Q60240

Q60241

Q60242

Q60243

Q60244

Q60245

Q60246

Q60247

Q60248

Q60249

Q60250

Q60251

Q60252

Q60253

Q60254

Q60255

Q60256

Q60257

Q60258

Q60259

Q60260

Q60261

Q60262

Q60263

Q60264

Q60265

Q60266

Q60267

Q60268

Q60269

Q60270

Q60271

Q60272

Q60273

Q60274

Q60275

Q60276

Q60277

Q60278

Q60279

Q60280

Q60281

Q60282

Q60283

Q60284

Q60285

Q60286

Q60287

Q60288

Q60289

Q60290

Q60291

Q60292

Q60293

Q60294

Q60295

Q60296

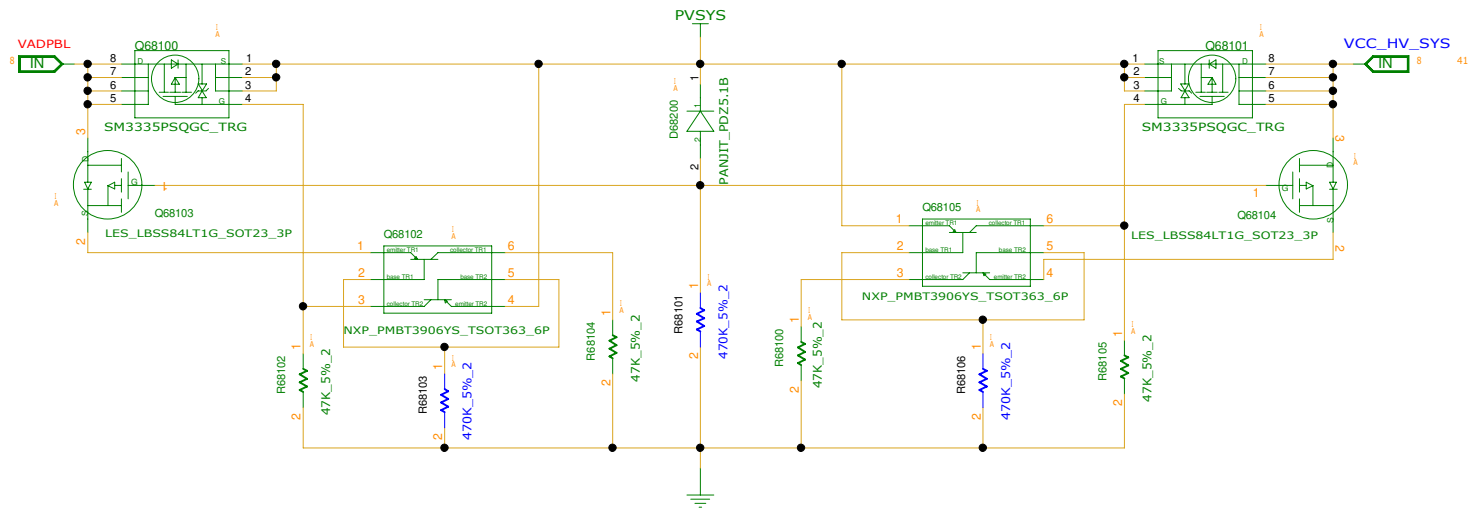

INVENTEC

TITLE			
MODEL, PROJECT, FUNCTION			
Block Diagram			
SIZE	CODE	DOC NUMBER	REV
A3	CS	1310xxxxx-0-0	X01
CHANGE by		DATE	21-OCT-2002
PCB P/N		PCB VER	XXX
SHEET		9 of 66	

CHANGE by	XXX	DATE	21-OCT-2002
PCB P/N	60xxxxxxxxxxx	PCB VER	XXX

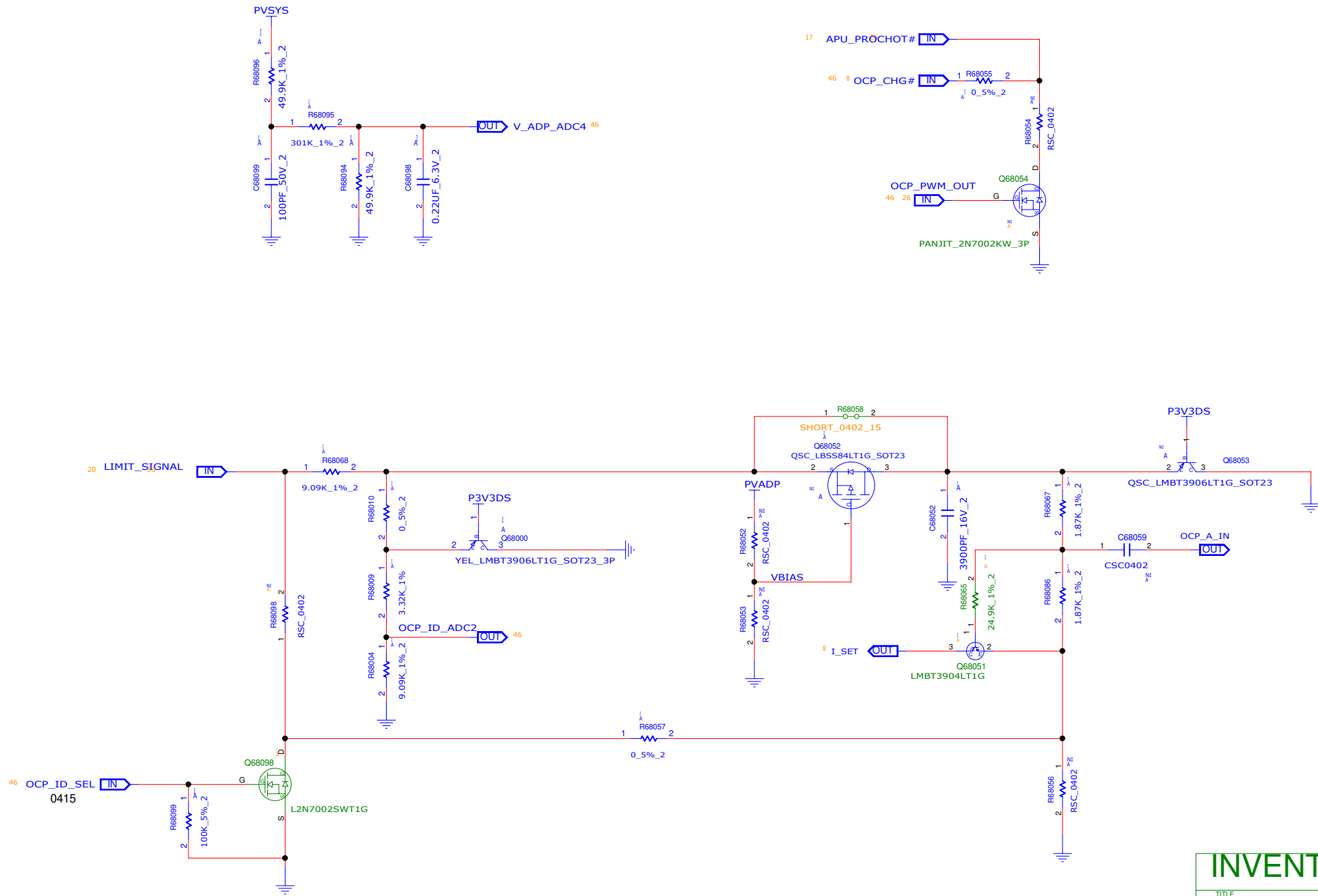

INVENTEC

TITLE			
MODEL, PROJECT, FUNCTION			
Block Diagram			
SIZE	CODE	DOC NUMBER	REV
A3	CS	1310xxxxx-0-0	X01
SHEET		10 of 66	

CHANGE by	XXX	DATE	21-OCT-2002
PCB P/N	60xxxxxxxxxxx	PCB VER	XXX

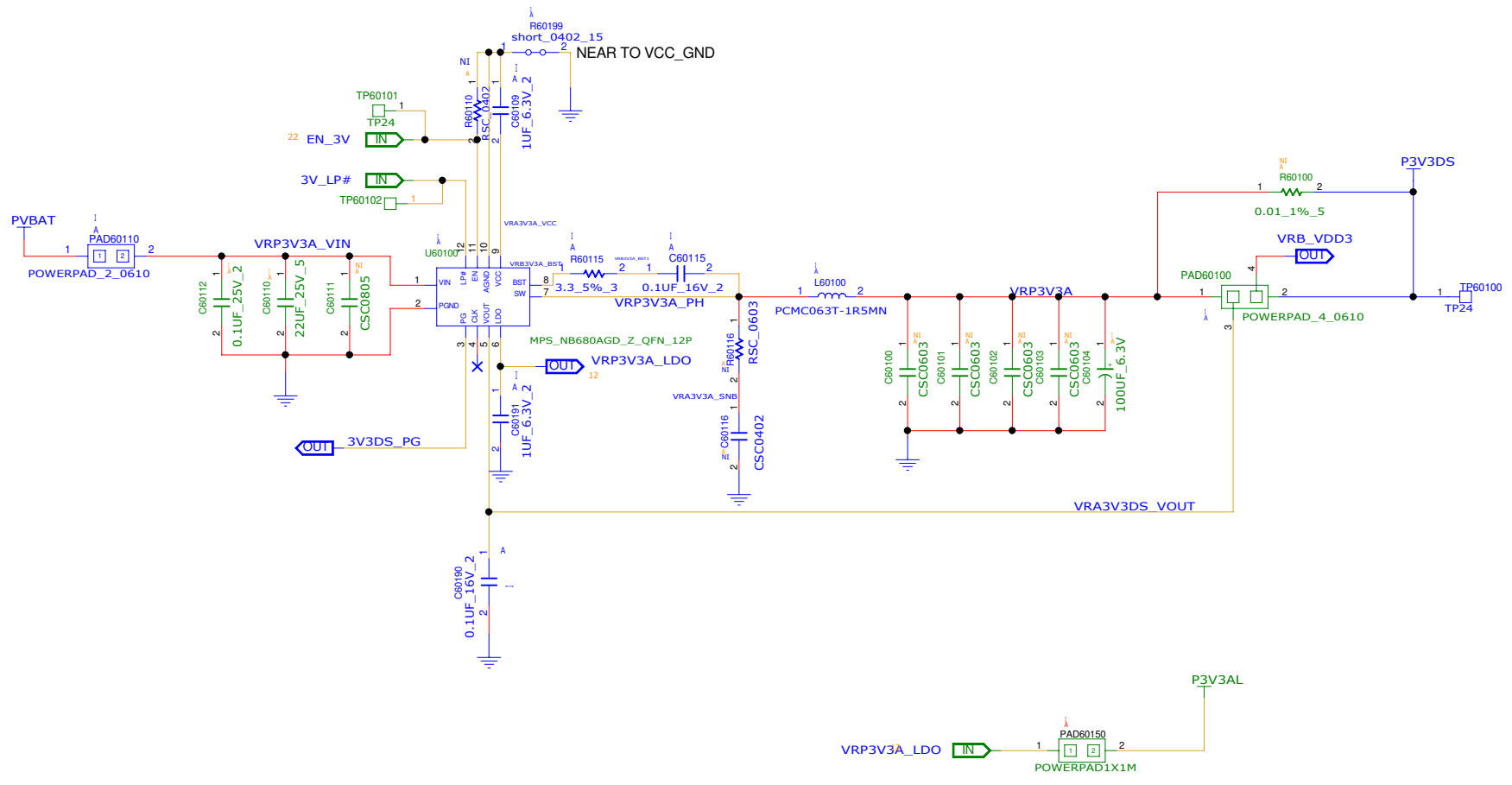

INVENTEC

TITLE			
MODEL, PROJECT, FUNCTION			
Block Diagram			
SIZE	CODE	DOC NUMBER	REV
A3	CS	1310xxxxx-0-0	X01
SHEET		12 of 66	

CHANGE by	XXX	DATE	21-OCT-2002
PCB P/N	60xxxxxxxxxxx	PCB VER	XXX

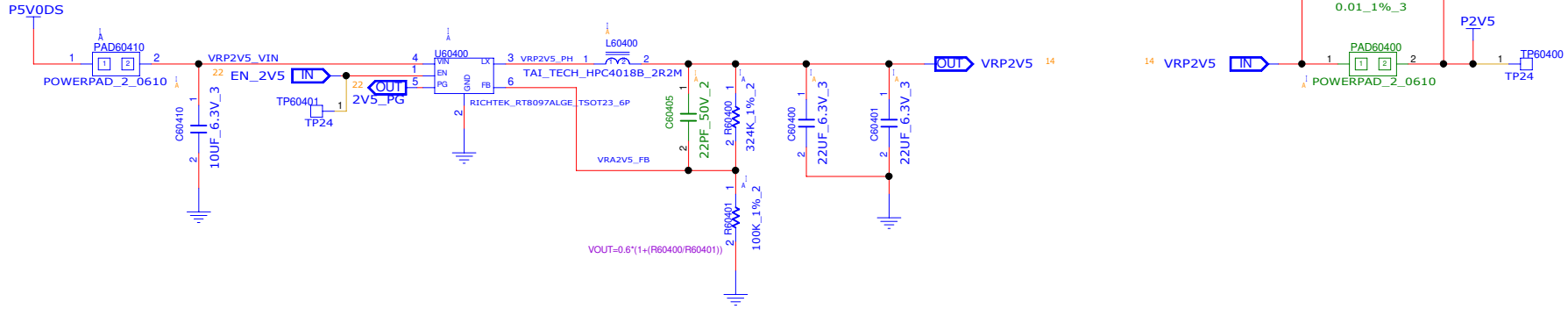

INVENTEC

TITLE			
MODEL, PROJECT, FUNCTION			
Block Diagram			
SIZE	CODE	DOC NUMBER	REV
A3	CS	1310xxxx-0-0	X01
SHEET		14 of 66	

CHANGE by	XXX	DATE	21-OCT-2002
PCB P/N	60xxxxxxxxxx	PCB VER	XXX

F_{SW}=500KHZ
 $VO = ((R60700/R60701)+1) * 0.8$

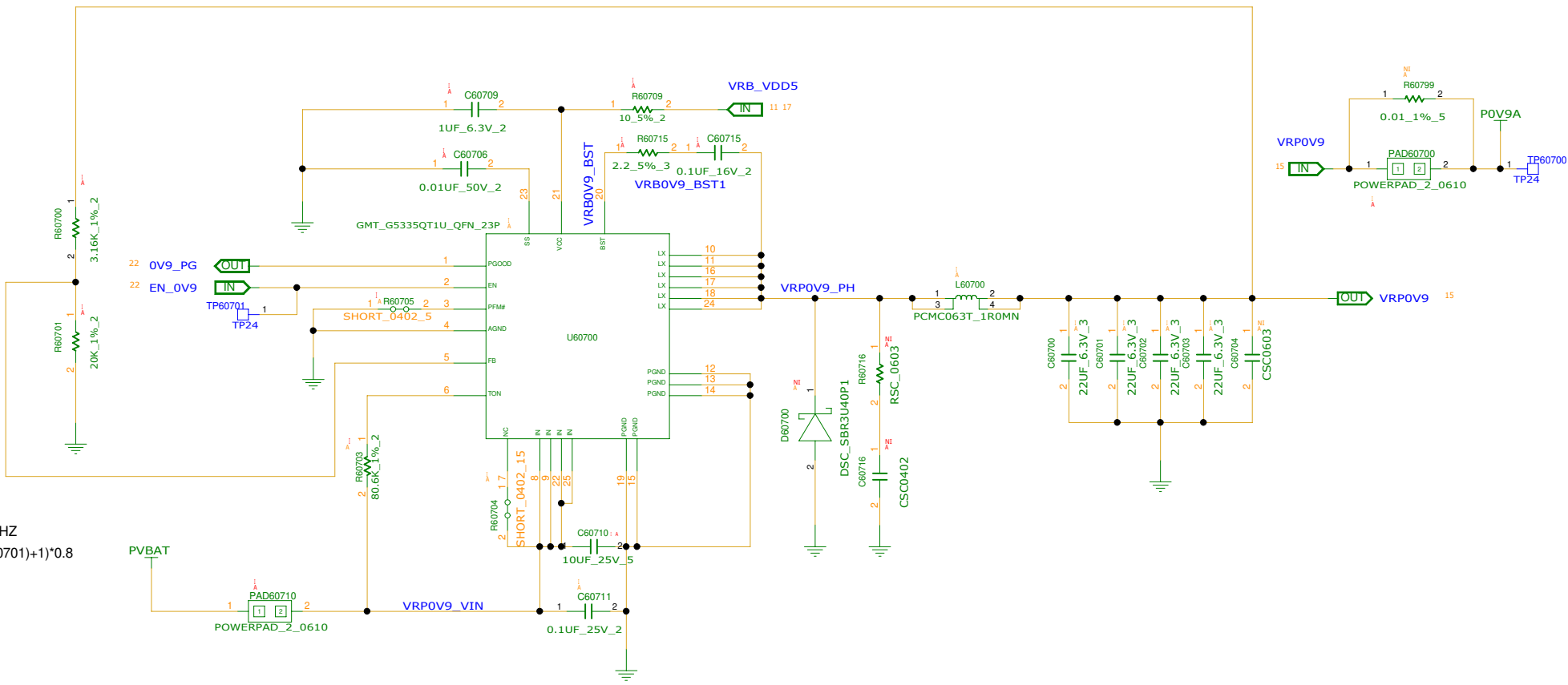

INVENTEC

TITLE: MODEL, PROJECT, FUNCTION
 Block Diagram

DOC NUMBER: 1310xxxx-0-0
 REV: X01

SIZE: A3
 CODE: CS
 SHEET: 15 of 66

CHANGE by	XXX	DATE	21-OCT-2002
PCB P/N	60xxxxxxxxxx	PCB VER	XXX

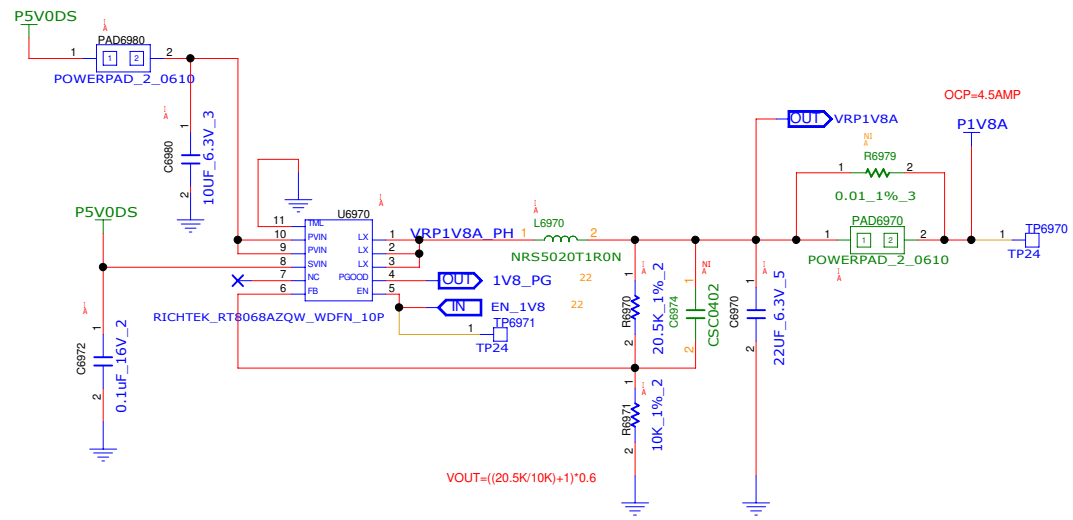

INVENTEC

TITLE			
MODEL, PROJECT, FUNCTION			
Block Diagram			
SIZE	CODE	DOC NUMBER	REV
A3	CS	1310xxxx-0-0	X01
SHEET		16 of 66	

CHANGE by	XXX	DATE	21-OCT-2002
PCB P/N	60xxxxxxxxxx	PCB VER	XXX

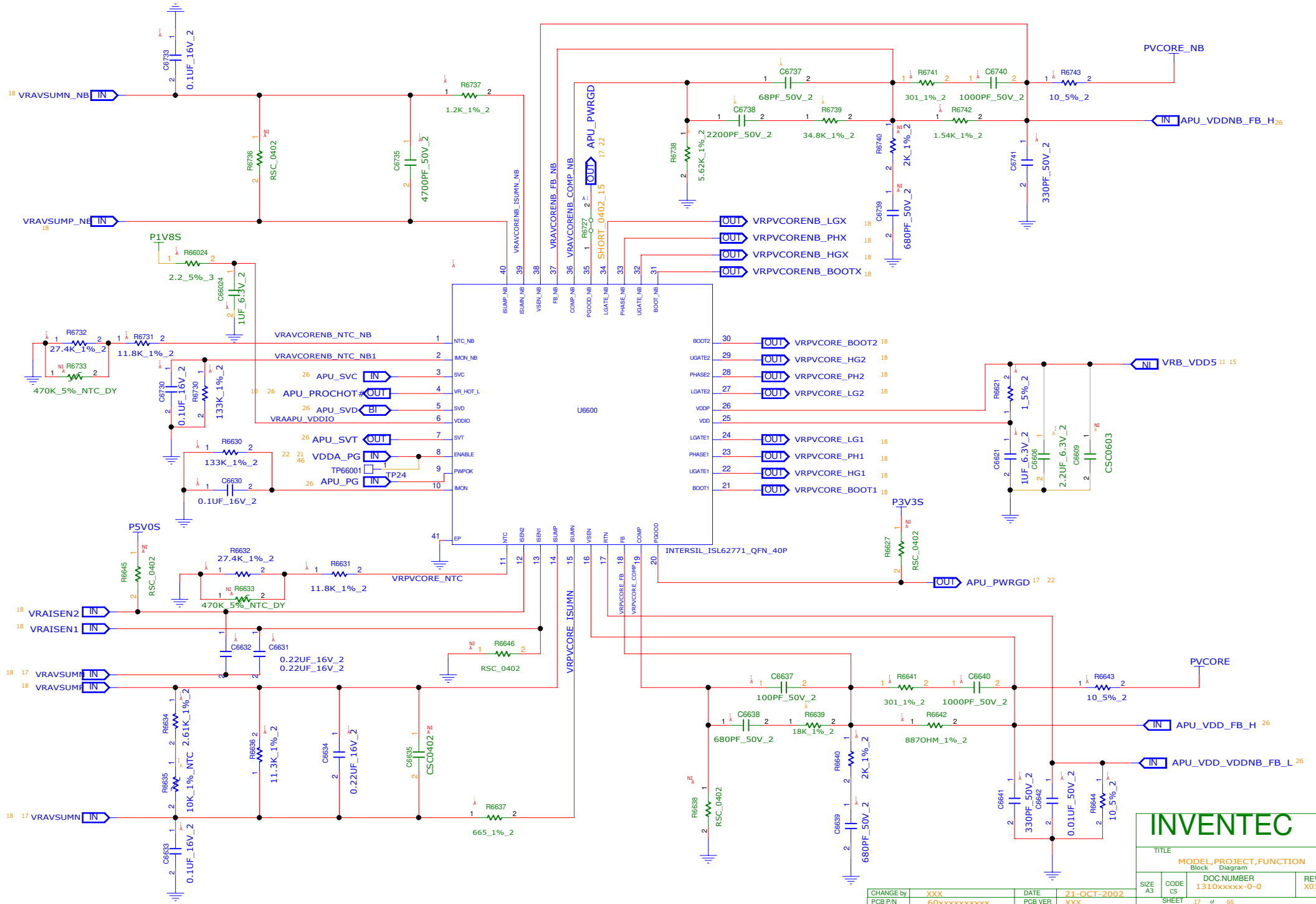

INVENTEC

TITLE			
MODEL,PROJECT,FUNCTION			
Block Diagram			
SIZE A3		CODE CS	REV X01
SHEET 17 of 66		DOC NUMBER 1310XXXX-0-0	

CHANGE by	XXX	DATE	21-OCT-2002
PCB P/N	60XXXXXXXXXX	PCB VER	XXX

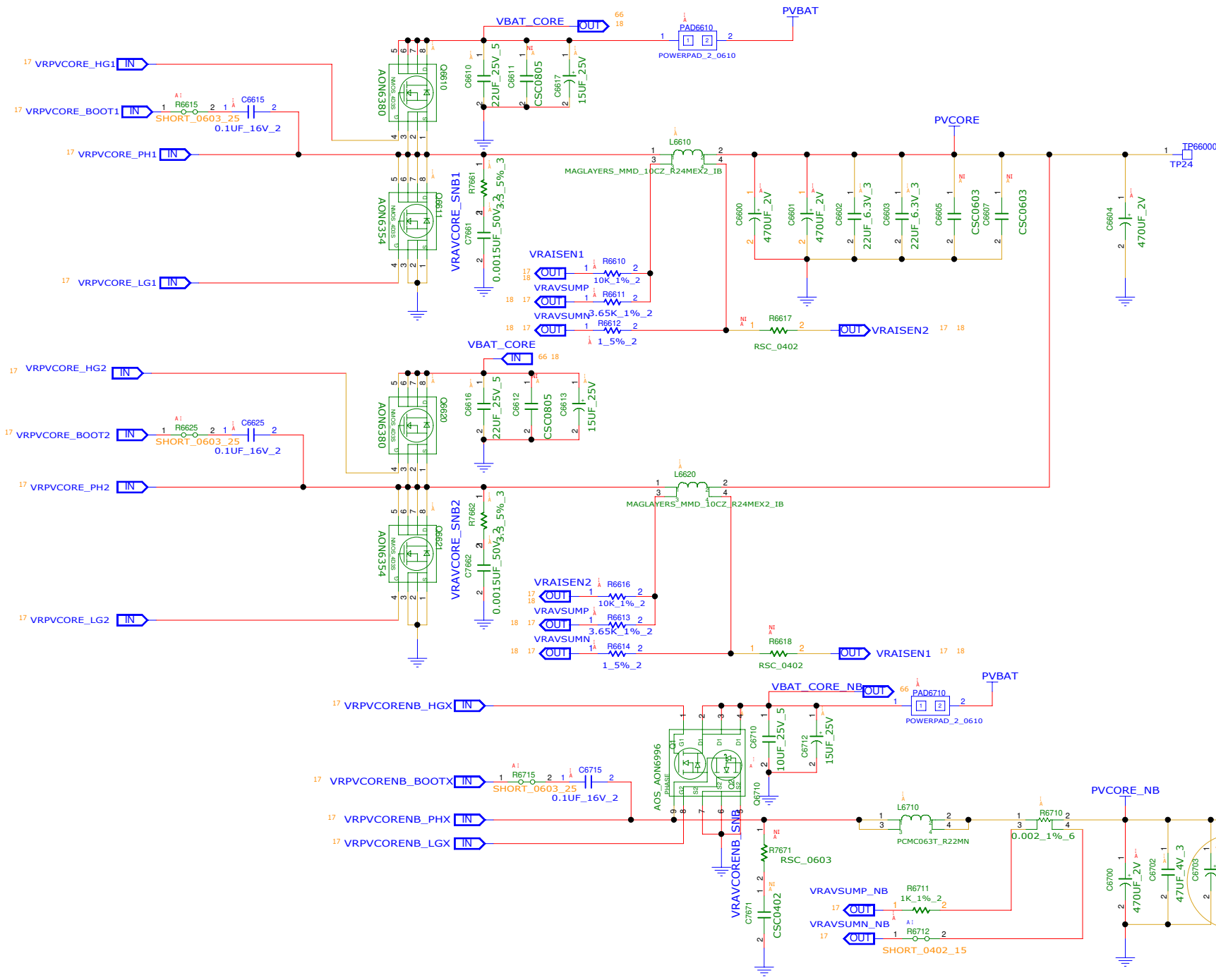

CLOSE TO CPU

INVENTEC

TITLE			
MODEL, PROJECT, FUNCTION			
Block Diagram			
SIZE	CODE	DOC NUMBER	REV
A3	CS	1310xxxx-0-0	X01
SHEET		18 of 66	

CHANGE by	XXX	DATE	21-OCT-2002
PCB P/N	60xxxxxxxxxxx	PCB VER	XXX

NA

INVENTEC

CHANGE by	XXX	DATE	21-OCT-2002	SIZE A3	CODE CS	DOC NUMBER	REV
PCB P/N	60xxxxxxxxxx	PCB VER	XXX	SHEET	19 of 66	1310xxxxx-0-0	X01

TITLE
MODEL,PROJECT,FUNCTION
NA

SIZE A3
CODE CS
SHEET 19 of 66

DOC NUMBER
1310xxxxx-0-0
REV
X01

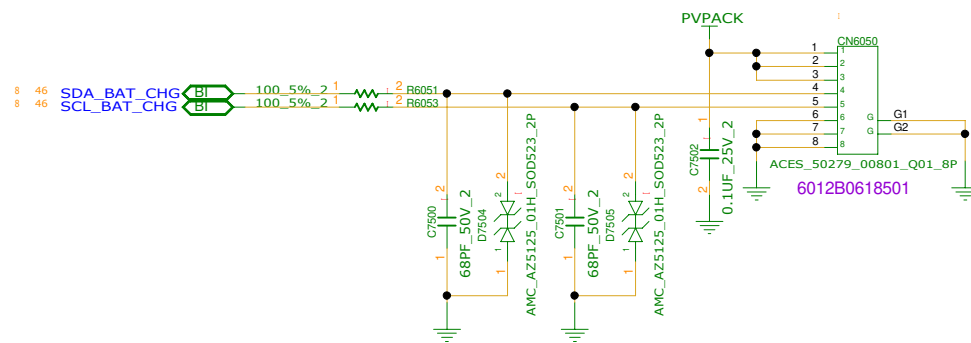
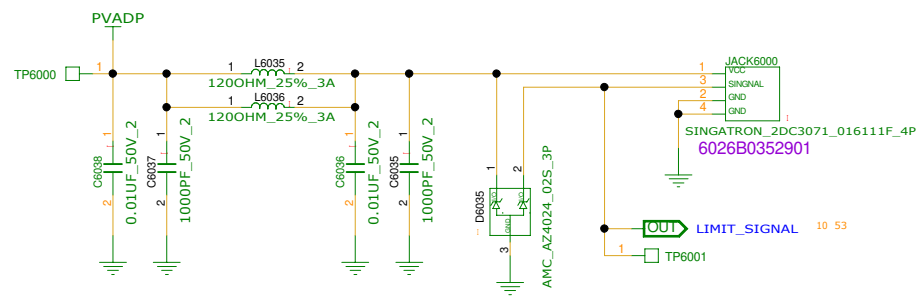

INVENTEC

TITLE			
MODEL PROJECT FUNCTION			
DC JACK & BATTERY CNTR			
SIZE A3	CODE CS	DOC NUMBER 1310xxxx-0-0	REV X01
SHEET 20 of 66			

CHANGE by	XXX	DATE	21-OCT-2002
PCB P/N	60xxxxxxxxxx	PCB VER	XXX

REFERENCE NUMBER : 7000~7350

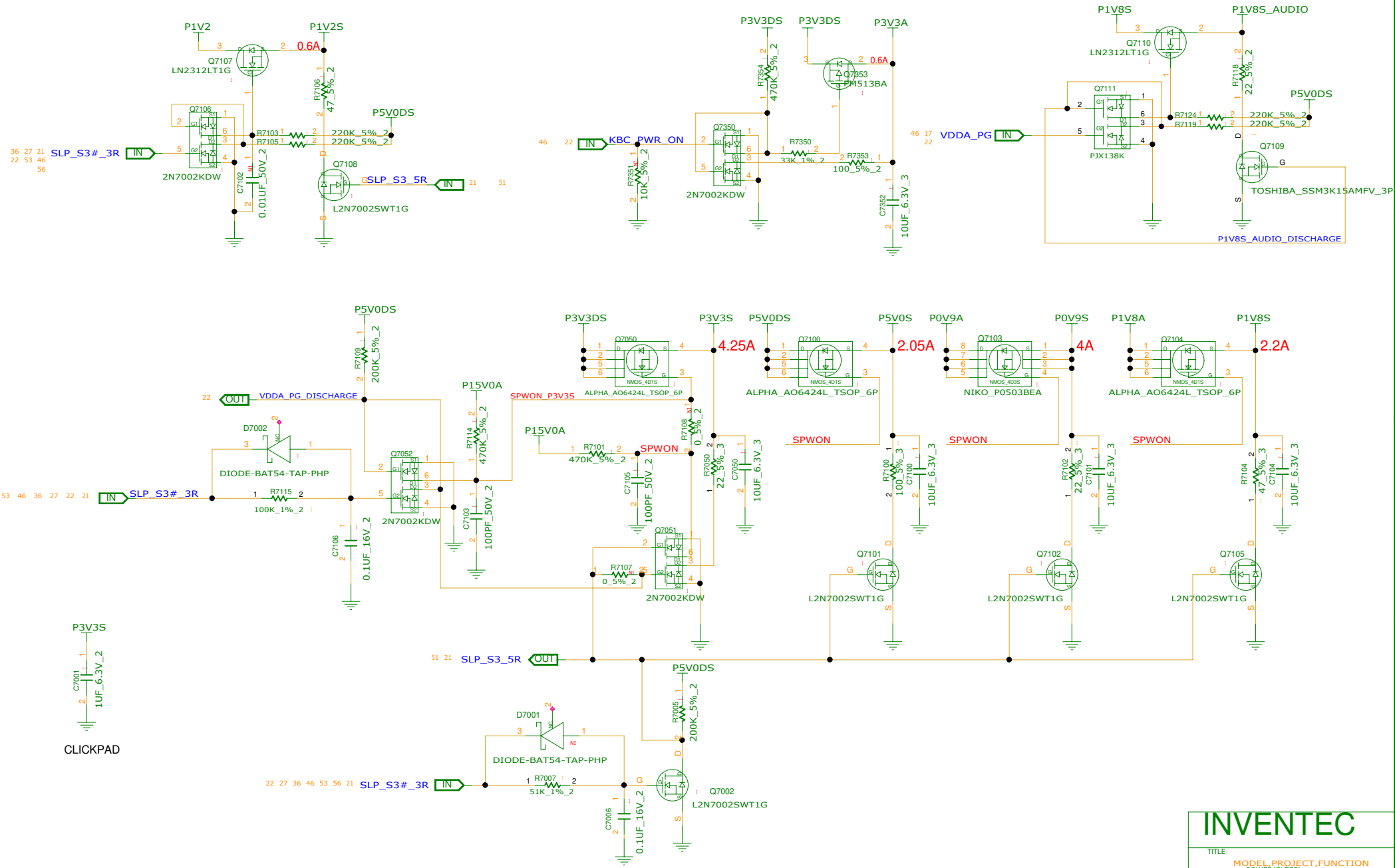

INVENTEC

TITLE			
MODEL PROJECT,FUNCTION			
POWER(SLEEP)			
DOC NUMBER			
1310xxxxx-0-0			
SIZE	CODE	REV	
A3	CS	X01	
SHEET		21 of 66	

CHANGE by	XXX	DATE	21-OCT-2002
PCB P/N	60xxxxxxxxxxx	PCB VER	XXX

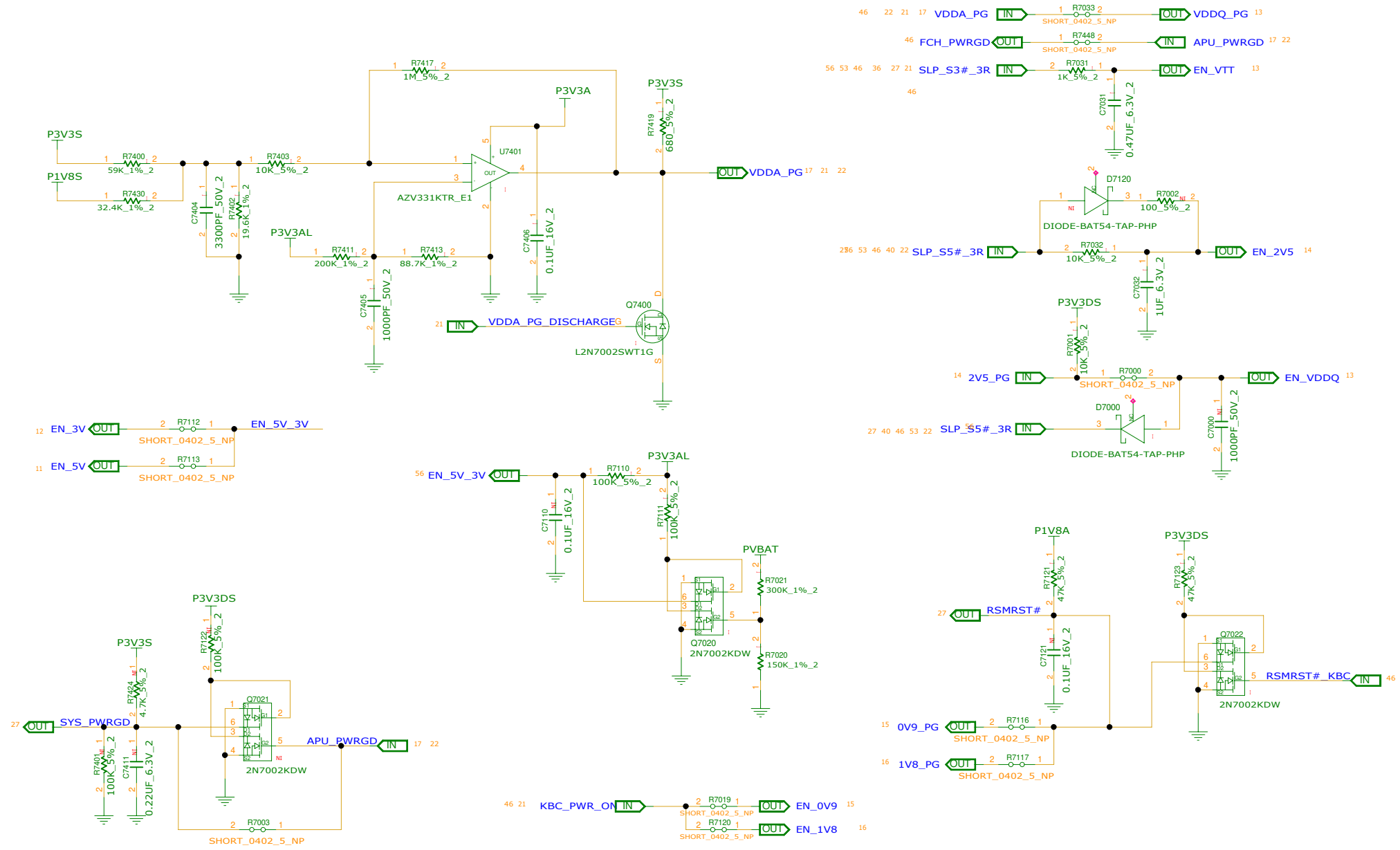

INVENTEC

TITLE			
MODEL PROJECT FUNCTION			
POWER SEQUENCE			
SIZE	CODE	DOC NUMBER	REV
A3	CS	1310xxxxx-0-0	X01
SHEET 22 of 66			

CHANGE by	XXX	DATE	21-OCT-2002
PCB P/N	60xxxxxxxxxxx	PCB VER	XXX

REFERENCE NUMBER:4300~4349

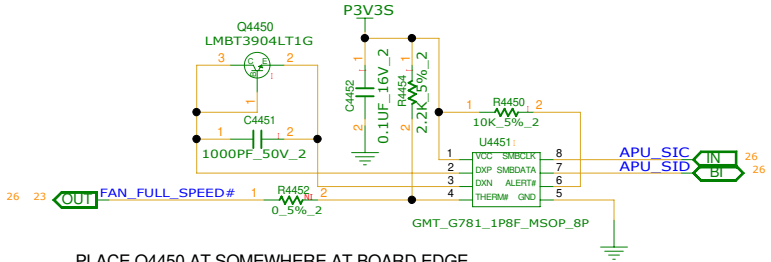
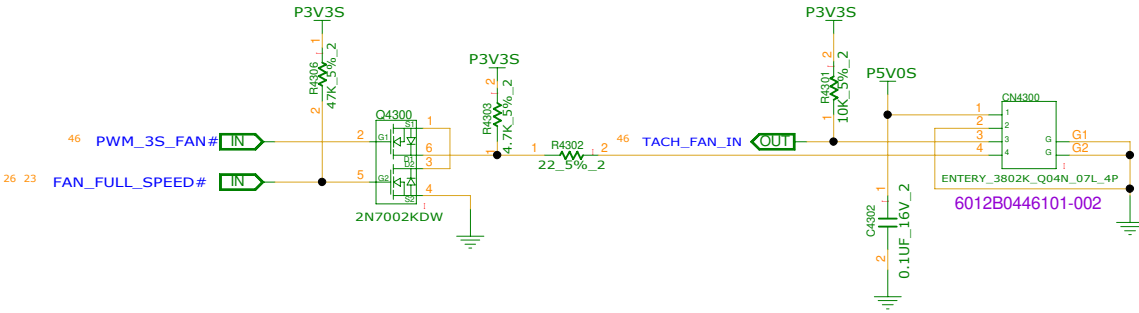

PLACE Q4450 AT SOMEWHERE AT BOARD EDGE

PLACE U4451 AT BOTTOM SIDE AND CLOSED TO CPU
BUT NOT INTERFERE WITH HIGH SPEED ROUTINGS

REFERENCE NUMBER:4450~4499

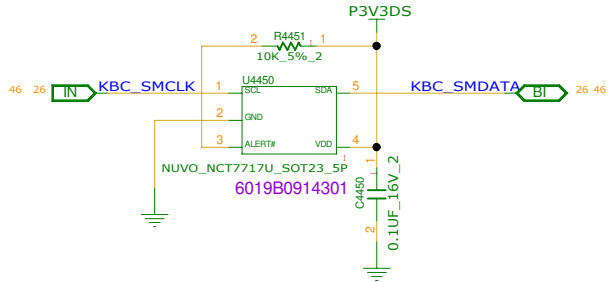

INVENTEC

TITLE			
MODEL,PROJECT,FUNCTION			
FAN & THERMAL			
SIZE	CODE	DOC NUMBER	REV
A3	CS	1310xxxxx-0-0	X01
SHEET		23 of 66	

CHANGE by	XXX	DATE	21-OCT-2002
PCB P/N	60xxxxxxxxxxx	PCB VER	XXX

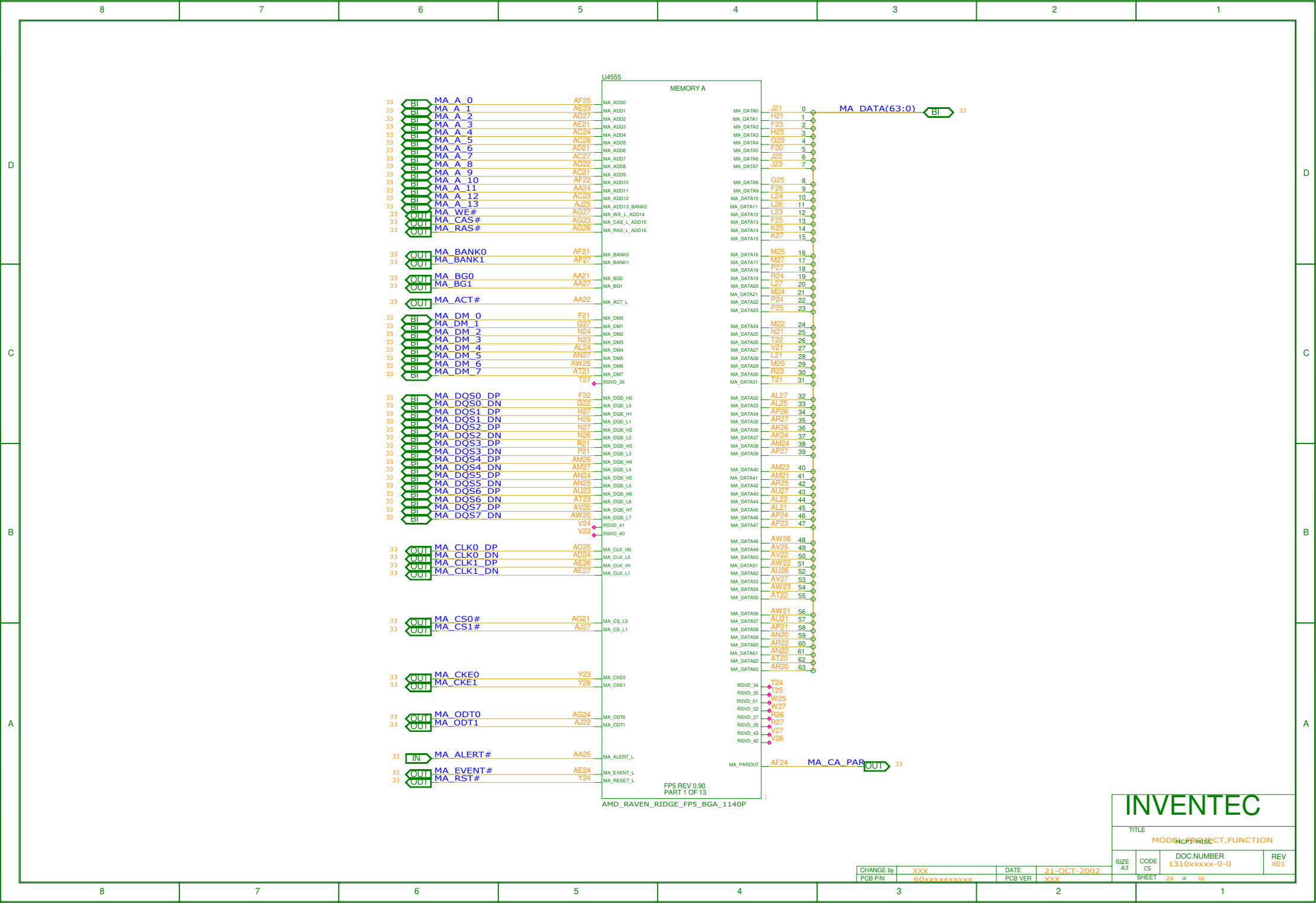

U4555
MEMORY A

33	BI	MA_A 0	AF25	MA_ADD0	MA_DATA0	J21	0	MA_DATA(63:0)	BI	33
33	BI	MA_A 1	AE23	MA_ADD1	MA_DATA1	H21	1			
33	BI	MA_A 2	AD27	MA_ADD2	MA_DATA2	F23	2			
33	BI	MA_A 3	AE21	MA_ADD3	MA_DATA3	H23	3			
33	BI	MA_A 4	AC24	MA_ADD4	MA_DATA4	G20	4			
33	BI	MA_A 5	AC26	MA_ADD5	MA_DATA5	F20	5			
33	BI	MA_A 6	AD21	MA_ADD6	MA_DATA6	J22	6			
33	BI	MA_A 7	AC27	MA_ADD7	MA_DATA7	J23	7			
33	BI	MA_A 8	AD22	MA_ADD8						
33	BI	MA_A 9	AC21	MA_ADD9						
33	BI	MA_A 10	AF22	MA_ADD10	MA_DATA8	G25	8			
33	BI	MA_A 11	AA24	MA_ADD11	MA_DATA9	F26	9			
33	BI	MA_A 12	AC23	MA_ADD12	MA_DATA10	L24	10			
33	BI	MA_A 13	AJ25	MA_ADD13_BANK2	MA_DATA11	L26	11			
33	OUT	MA_WE#	AG27	MA_WE_L_ADD14	MA_DATA12	L23	12			
33	OUT	MA_CAS#	AG23	MA_CAS_L_ADD15	MA_DATA13	F25	13			
33	OUT	MA_RAS#	AG26	MA_RAS_L_ADD16	MA_DATA14	K25	14			
					MA_DATA15	K27	15			
33	OUT	MA_BANK0	AF21	MA_BANK0	MA_DATA16	M25	16			
33	OUT	MA_BANK1	AF27	MA_BANK1	MA_DATA17	M27	17			
33	OUT	MA_BG0	AA21	MA_BG0	MA_DATA18	P27	18			
33	OUT	MA_BG1	AA27	MA_BG1	MA_DATA19	R24	19			
33	OUT	MA_ACT#	AA22	MA_ACT_L	MA_DATA20	L27	20			
					MA_DATA21	M24	21			
33	BI	MA_DM 0	F21	MA_DM0	MA_DATA22	P24	22			
33	BI	MA_DM 1	G27	MA_DM1	MA_DATA23	F25	23			
33	BI	MA_DM 2	N24	MA_DM2						
33	BI	MA_DM 3	N23	MA_DM3	MA_DATA24	M22	24			
33	BI	MA_DM 4	AL24	MA_DM4	MA_DATA25	N21	25			
33	BI	MA_DM 5	AN27	MA_DM5	MA_DATA26	T22	26			
33	BI	MA_DM 6	AW25	MA_DM6	MA_DATA27	V21	27			
33	BI	MA_DM 7	AT21	MA_DM7	MA_DATA28	L21	28			
			T27	RSVD_36	MA_DATA29	M20	29			
					MA_DATA30	R23	30			
					MA_DATA31	T21	31			
33	BI	MA_DQS0 DP	F23	MA_DQS_H0	MA_DATA32	AL27	32			
33	BI	MA_DQS0 DN	G22	MA_DQS_L0	MA_DATA33	AL25	33			
33	BI	MA_DQS1 DP	H27	MA_DQS_H1	MA_DATA34	AP26	34			
33	BI	MA_DQS1 DN	H26	MA_DQS_L1	MA_DATA35	AR27	35			
33	BI	MA_DQS2 DP	N27	MA_DQS_H2	MA_DATA36	AK26	36			
33	BI	MA_DQS2 DN	N26	MA_DQS_L2	MA_DATA37	AK24	37			
33	BI	MA_DQS3 DP	R21	MA_DQS_H3	MA_DATA38	AM24	38			
33	BI	MA_DQS3 DN	F21	MA_DQS_L3	MA_DATA39	AP27	39			
33	BI	MA_DQS4 DP	AM26	MA_DQS_H4						
33	BI	MA_DQS4 DN	AM27	MA_DQS_L4	MA_DATA40	AM23	40			
33	BI	MA_DQS5 DP	AN24	MA_DQS_H5	MA_DATA41	AM21	41			
33	BI	MA_DQS5 DN	AN25	MA_DQS_L5	MA_DATA42	AR25	42			
33	BI	MA_DQS6 DP	AU23	MA_DQS_H6	MA_DATA43	AU27	43			
33	BI	MA_DQS6 DN	AT23	MA_DQS_L6	MA_DATA44	AL22	44			
33	BI	MA_DQS7 DP	AV20	MA_DQS_H7	MA_DATA45	AL21	45			
33	BI	MA_DQS7 DN	AW20	MA_DQS_L7	MA_DATA46	AP24	46			
			V24	RSVD_41	MA_DATA47	AP23	47			
			V23	RSVD_40						
33	OUT	MA_CLK0 DP	AD25	MA_CLK_H0	MA_DATA48	AW26	48			
33	OUT	MA_CLK0 DN	AD24	MA_CLK_L0	MA_DATA49	AV25	49			
33	OUT	MA_CLK1 DP	AE26	MA_CLK_H1	MA_DATA50	AV22	50			
33	OUT	MA_CLK1 DN	AE27	MA_CLK_L1	MA_DATA51	AW22	51			
					MA_DATA52	AU26	52			
					MA_DATA53	AV27	53			
					MA_DATA54	AW23	54			
					MA_DATA55	AT22	55			
33	OUT	MA_CS0#	AG21	MA_CS_L0	MA_DATA56	AW21	56			
33	OUT	MA_CS1#	AJ27	MA_CS_L1	MA_DATA57	AU21	57			
					MA_DATA58	AP21	58			
					MA_DATA59	AN20	59			
					MA_DATA60	AR22	60			
					MA_DATA61	AN22	61			
					MA_DATA62	AT20	62			
					MA_DATA63	AR20	63			
33	OUT	MA_CKE0	Y23	MA_CKE0	RSVD_34	T24				
33	OUT	MA_CKE1	Y26	MA_CKE1	RSVD_35	T25				
					RSVD_51	W25				
					RSVD_52	W27				
					RSVD_27	R26				
					RSVD_28	R27				
					RSVD_43	V26				
					RSVD_42	V26				
33	IN	MA_ALERT#	AA25	MA_ALERT_L	MA_PAROUT	AF24				
33	OUT	MA_EVENT#	AE24	MA_EVENT_L						
33	OUT	MA_RST#	Y24	MA_RESET_L						

FP5 REV 0.90
PART 1 OF 13

AMD_RAVEN_RIDGE_FP5_BGA_1140P

INVENTEC

TITLE: **MODEM PCIE**
MODE: **MODEM PCIE, FUNCTION**

SIZE A3 CODE CS DOC NUMBER 1310XXXX-0-0 REV X01

CHANGE by: XXX DATE: 21-OCT-2002
PCB P/N: 60XXXXXXXXXX PCB VER: XXX

SHEET 24 of 66

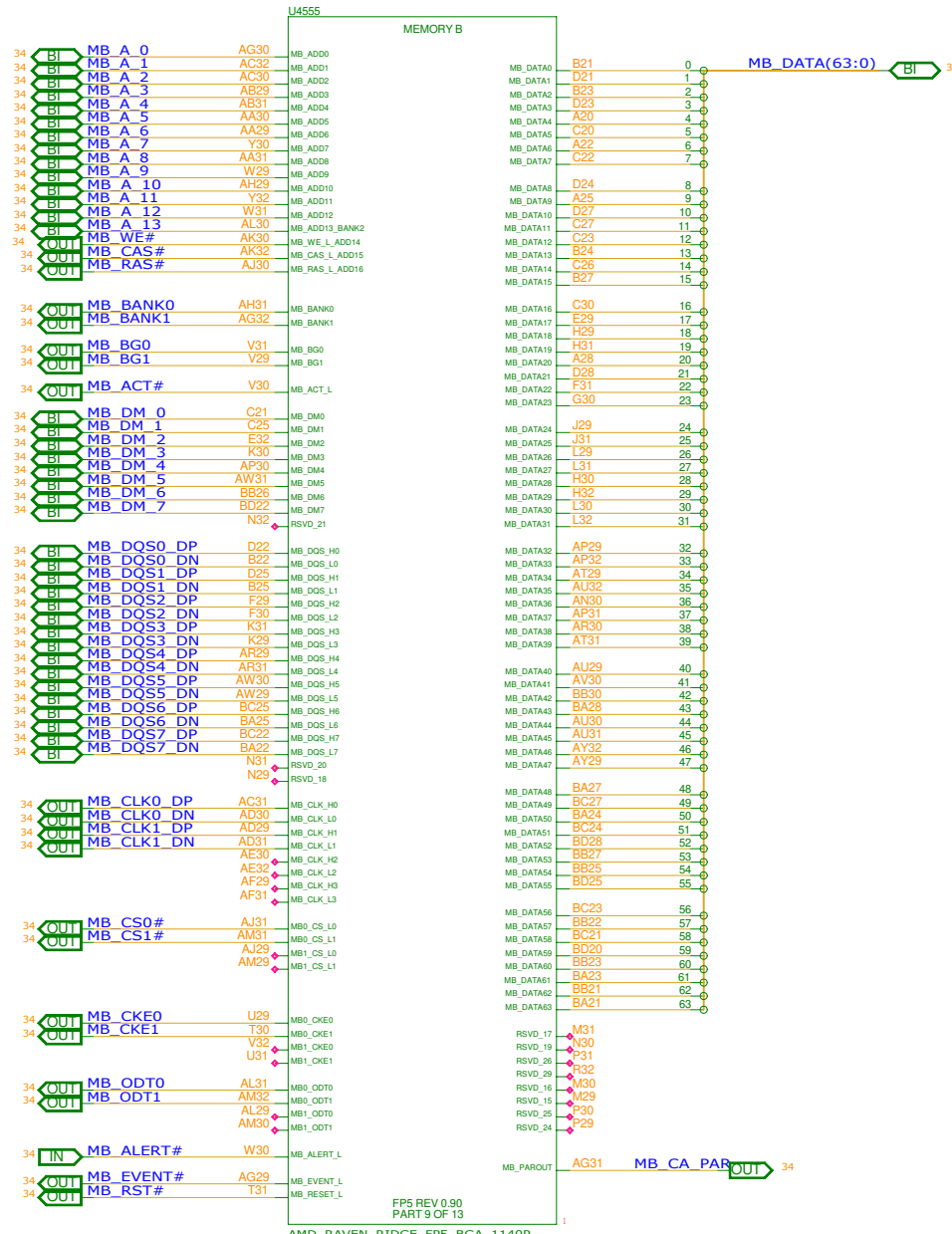

FPS REV 0.90
PART 9 OF 13
AMD_RAVEN_RIDGE_FPS_BGA_1140P

INVENTEC

TITLE
MCP2542 USB & SYSTEM SEQUENCE

SIZE A3 CODE CS DOC NUMBER 1310xxxx-0-0 REV X01
SHEET 25 of 66

CHANGE by	XXX	DATE	21-OCT-2002
PCB P/N	60xxxxxxxxxx	PCB VER	XXX

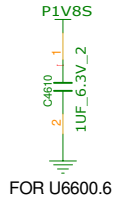
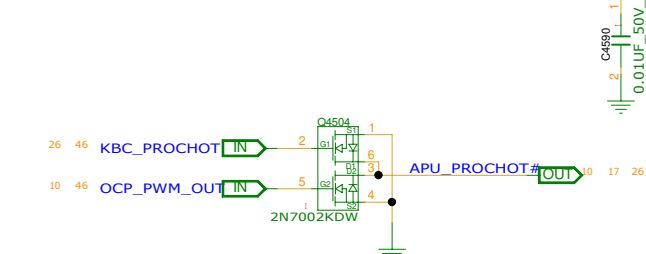
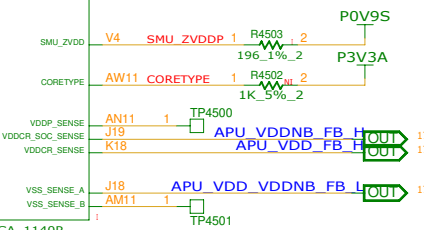
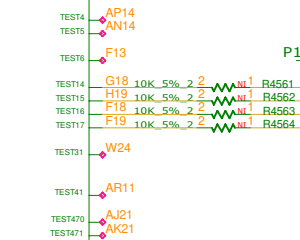
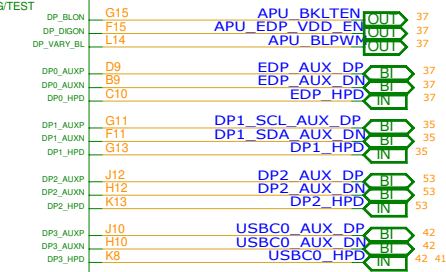
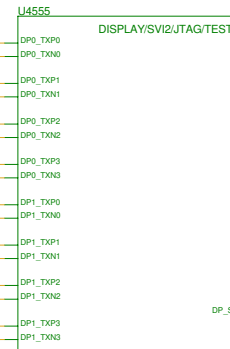
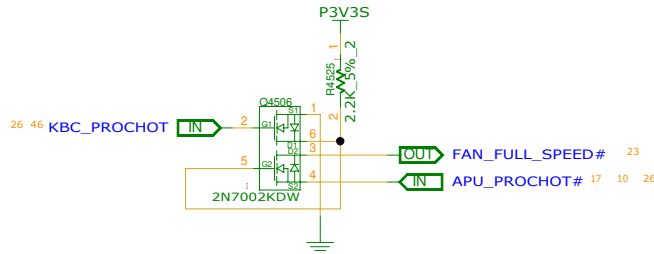
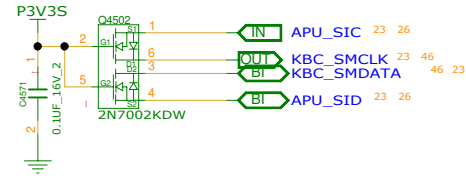
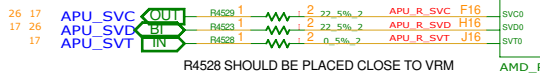
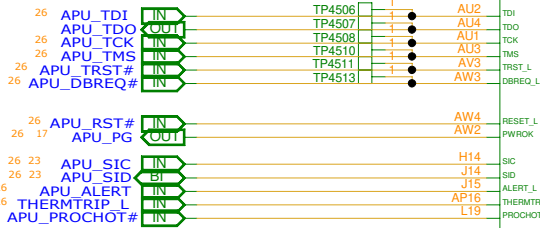
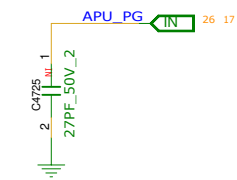
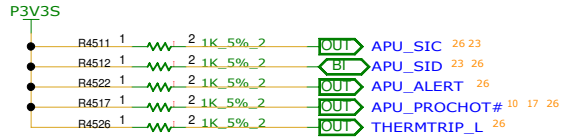
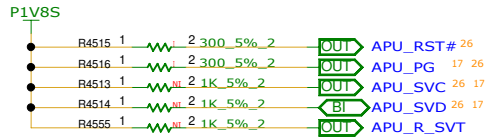
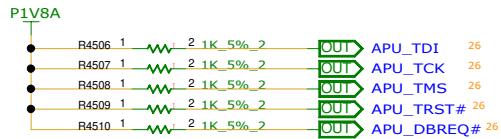

PU FOR INTERNAL PD FOR CUSTOMER

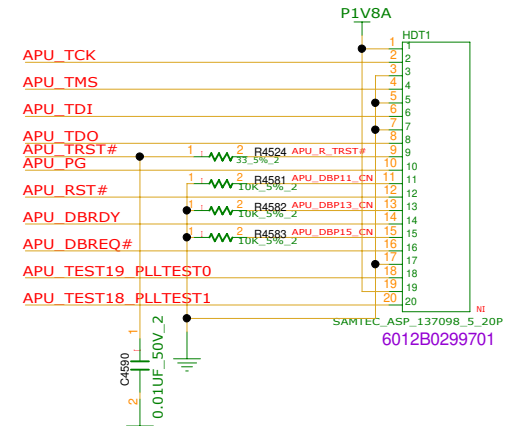

INVENTEC			
TITLE MODEL, PROJECT, FUNCTION Block Diagram			
SIZE A3	CODE CS	DOC NUMBER 1310xxxx-0-0	REV X01
CHANGE by PCB P/N		DATE PCB VER	21-OCT-2002 XXX
SHEET		26 of 66	

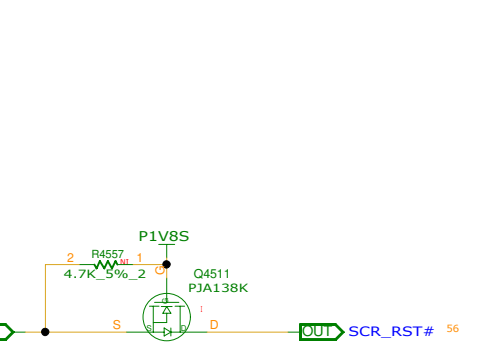
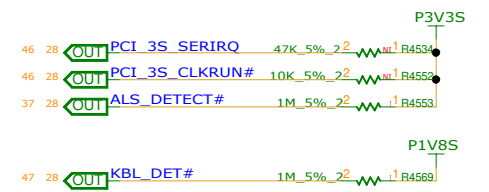
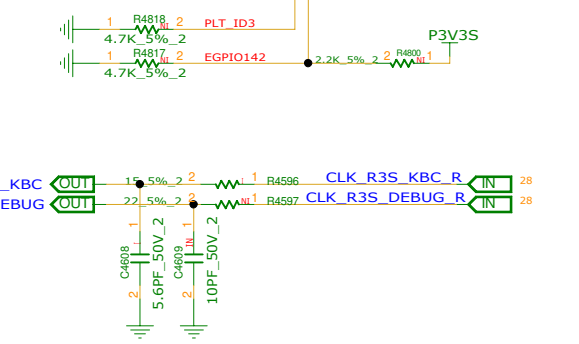
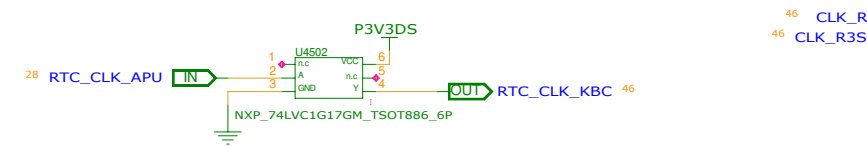
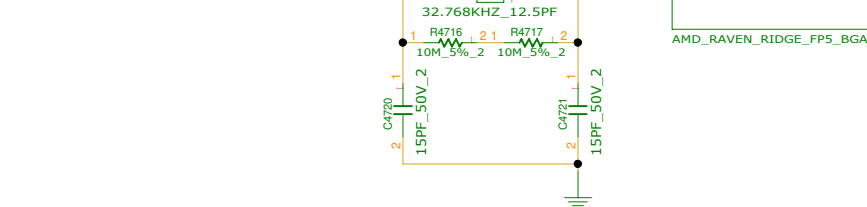
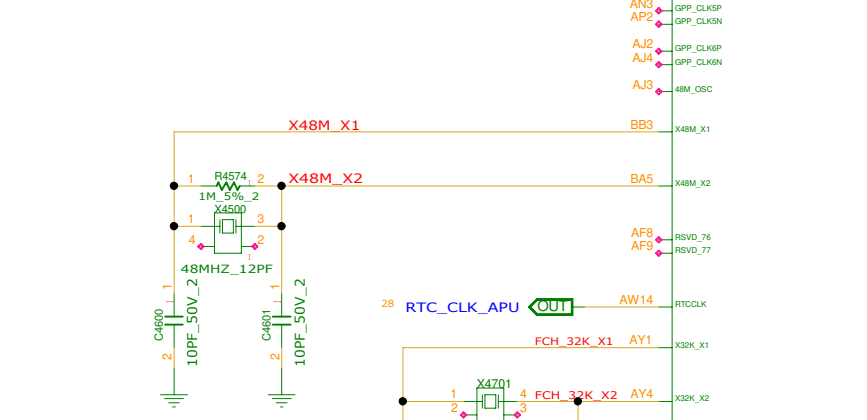
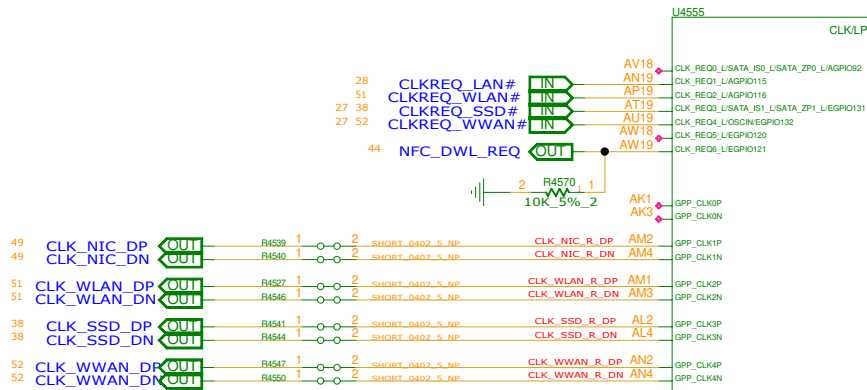
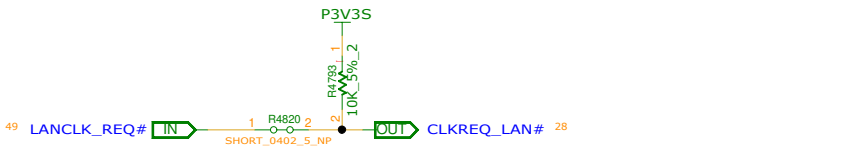

PLATFORM ID	P_ID1 EGPIO141 INTERNAL PD	P_ID2 EGPIO142 INTERNAL PH	P_ID3 EGPIO143 INTERNAL PH
LLARGA13"	0	0	1
TENJIN 14"	0	1	0
TENJIN 15"	0	1	1

INVENTEC

TITLE: MODEL,PROJECT,FUNCTION
MCP5-DDR

SIZE A3	CODE CS	DOC NUMBER 1310xxxxx-0-0	REV X01
SHEET 28 of 66			

CHANGE by	XXX	DATE	21-OCT-2002
PCB P/N	60xxxxxxxxxxx	PCB VER	XXX

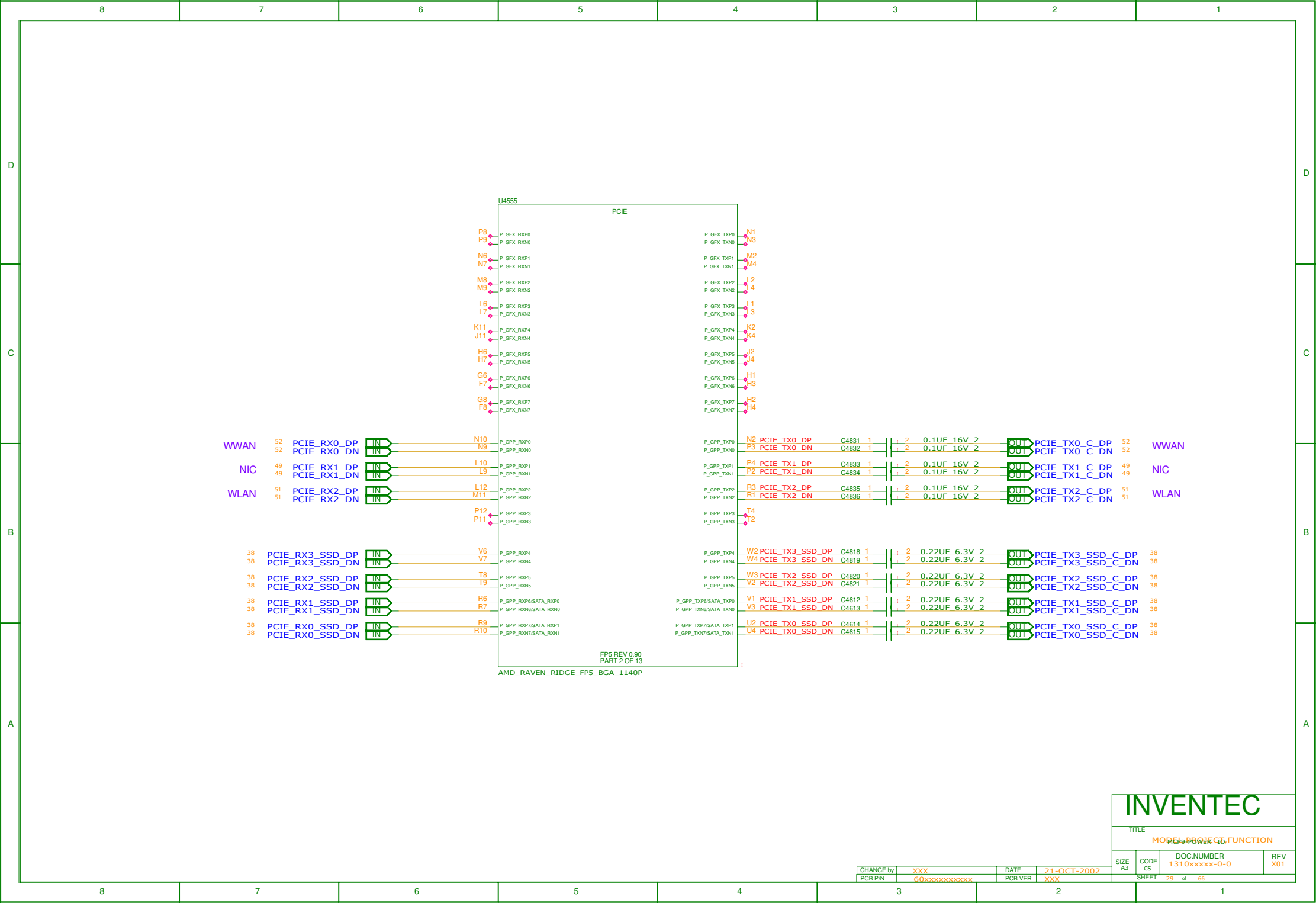

Ref	Component	Value	Part	QTY	Value	Vol	Cur	Dir	Ref	Component	Value	Part	QTY	Value	Vol	Cur	Dir	Ref
52	PCIE_RX0_DP	IN	N10	P_GPP_RXP0	P2	PCIE TX0 DP	C4831	1	1	2	0.1UF	16V	2	OUT	PCIE_TX0_C_DP	52	WWAN	
52	PCIE_RX0_DN	IN	N9	P_GPP_RXN0	P3	PCIE TX0 DN	C4832	1	1	2	0.1UF	16V	2	OUT	PCIE_TX0_C_DN	52	WWAN	
49	PCIE_RX1_DP	IN	L10	P_GPP_RXP1	P4	PCIE TX1 DP	C4833	1	1	2	0.1UF	16V	2	OUT	PCIE_TX1_C_DP	49	NIC	
49	PCIE_RX1_DN	IN	L9	P_GPP_RXN1	P2	PCIE TX1 DN	C4834	1	1	2	0.1UF	16V	2	OUT	PCIE_TX1_C_DN	49	NIC	
51	PCIE_RX2_DP	IN	L12	P_GPP_RXP2	R3	PCIE TX2 DP	C4835	1	1	2	0.1UF	16V	2	OUT	PCIE_TX2_C_DP	51	WLAN	
51	PCIE_RX2_DN	IN	M11	P_GPP_RXN2	R1	PCIE TX2 DN	C4836	1	1	2	0.1UF	16V	2	OUT	PCIE_TX2_C_DN	51	WLAN	
38	PCIE_RX3_SSD_DP	IN	V6	P_GPP_RXP4	W2	PCIE TX3 SSD DP	C4818	1	1	2	0.22UF	6.3V	2	OUT	PCIE_TX3_SSD_C_DP	38		
38	PCIE_RX3_SSD_DN	IN	V7	P_GPP_RXN4	W4	PCIE TX3 SSD DN	C4819	1	1	2	0.22UF	6.3V	2	OUT	PCIE_TX3_SSD_C_DN	38		
38	PCIE_RX2_SSD_DP	IN	T8	P_GPP_RXP5	W3	PCIE TX2 SSD DP	C4820	1	1	2	0.22UF	6.3V	2	OUT	PCIE_TX2_SSD_C_DP	38		
38	PCIE_RX2_SSD_DN	IN	T9	P_GPP_RXN5	V2	PCIE TX2 SSD DN	C4821	1	1	2	0.22UF	6.3V	2	OUT	PCIE_TX2_SSD_C_DN	38		
38	PCIE_RX1_SSD_DP	IN	R6	P_GPP_RXP6/SATA_RXP0	V1	PCIE TX1 SSD DP	C4612	1	1	2	0.22UF	6.3V	2	OUT	PCIE_TX1_SSD_C_DP	38		
38	PCIE_RX1_SSD_DN	IN	H7	P_GPP_RXN6/SATA_RXN0	V3	PCIE TX1 SSD DN	C4613	1	1	2	0.22UF	6.3V	2	OUT	PCIE_TX1_SSD_C_DN	38		
38	PCIE_RX0_SSD_DP	IN	R9	P_GPP_RXP7/SATA_RXP1	U2	PCIE TX0 SSD DP	C4614	1	1	2	0.22UF	6.3V	2	OUT	PCIE_TX0_SSD_C_DP	38		
38	PCIE_RX0_SSD_DN	IN	R10	P_GPP_RXN7/SATA_RXN1	U4	PCIE TX0 SSD DN	C4615	1	1	2	0.22UF	6.3V	2	OUT	PCIE_TX0_SSD_C_DN	38		

FPS REV 0.90
PART 2 OF 13

AMD_RAVEN_RIDGE_FP5_BGA_1140P

INVENTEC

TITLE: **MOBILE POWER CB FUNCTION**

SIZE A3 CODE CS DOC NUMBER 1310XXXX-0-0 REV X01

SHEET 29 of 66

CHANGE by	XXX	DATE	21-OCT-2002
PCB P/N	60XXXXXXXXXX	PCB VER	XXX

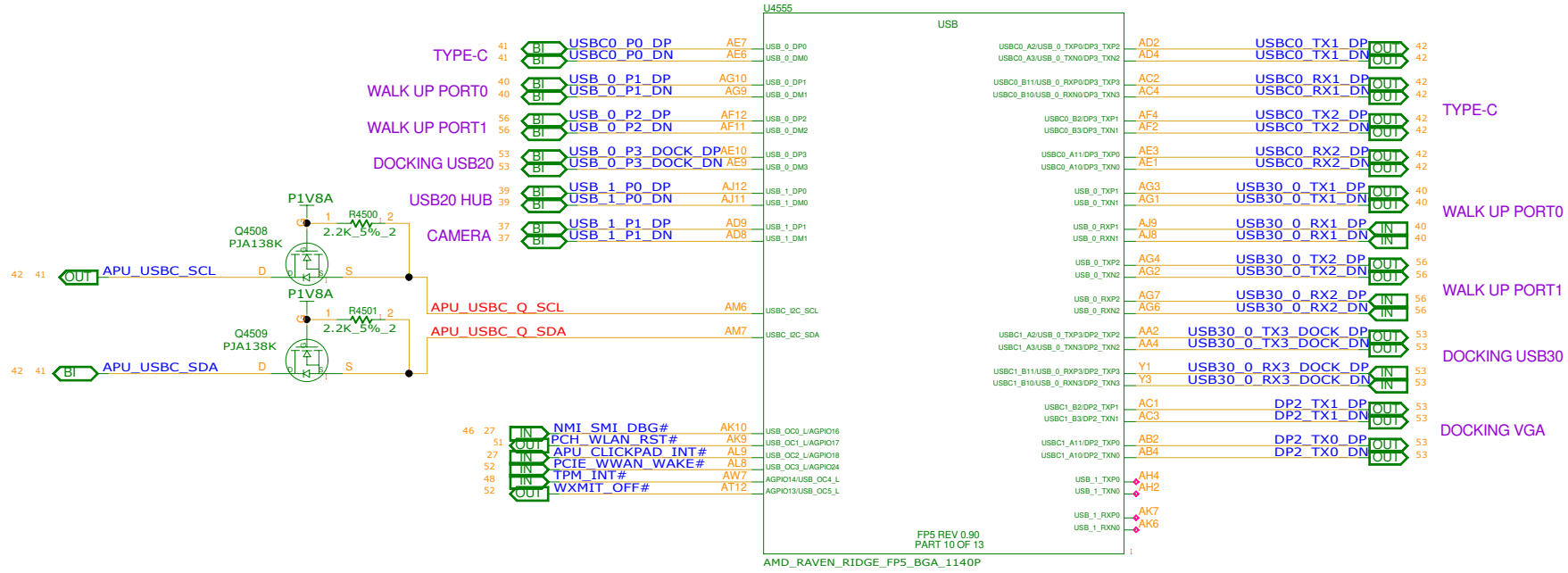

INVENTEC

TITLE: MCHP10 POWER/FUNCTION

SIZE A3 CODE CS DOC NUMBER 1310XXXX-0-0 REV X01

SHEET 30 of 66

CHANGE by	XXX	DATE	21-OCT-2002
PCB P/N	60XXXXXXXXXX	PCB VER	XXX

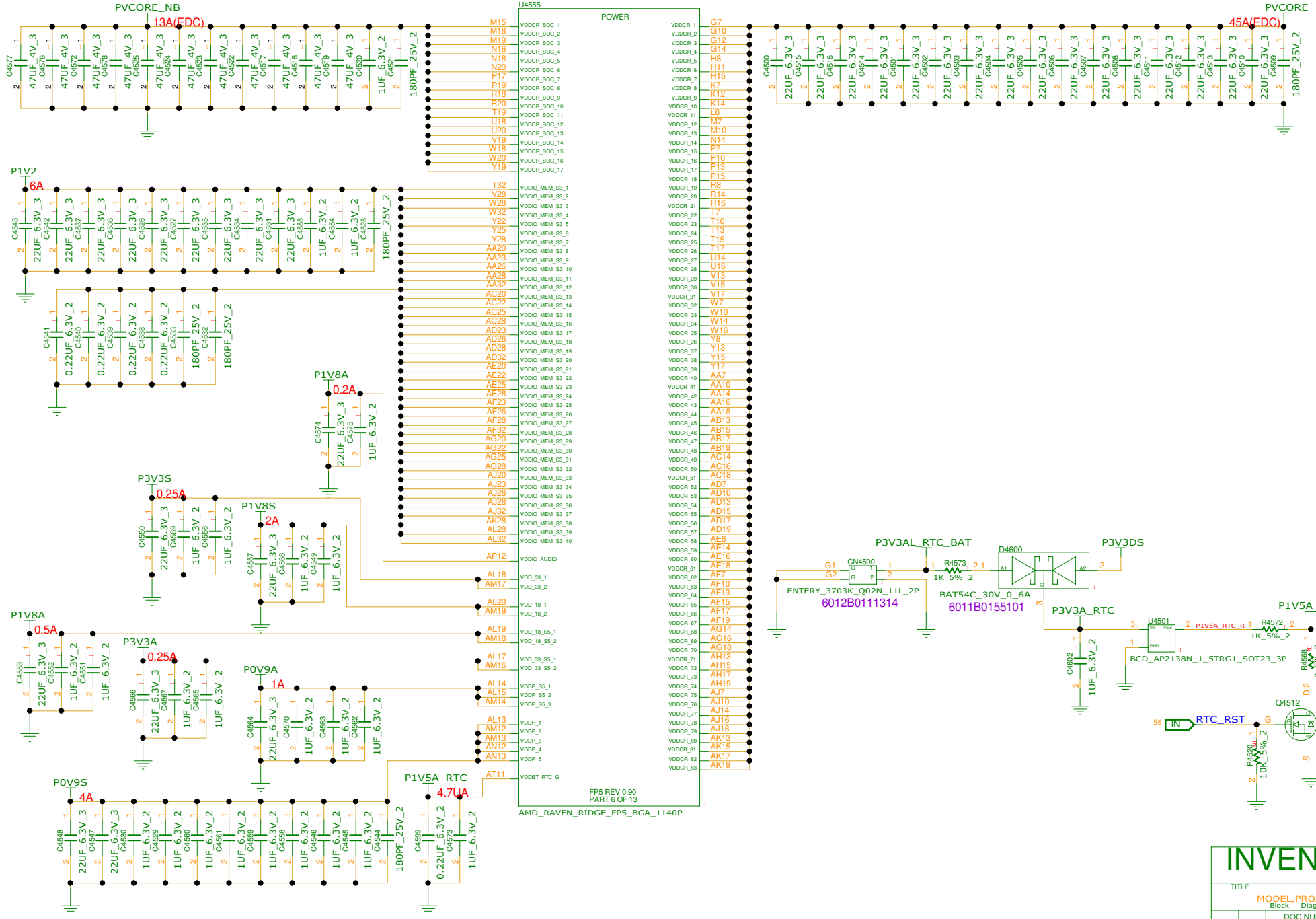

- U4555
- M15 VDDCR_SOC_1
 - M18 VDDCR_SOC_2
 - M19 VDDCR_SOC_3
 - N16 VDDCR_SOC_4
 - N18 VDDCR_SOC_5
 - N20 VDDCR_SOC_6
 - P17 VDDCR_SOC_7
 - R18 VDDCR_SOC_8
 - R19 VDDCR_SOC_9
 - R20 VDDCR_SOC_10
 - T19 VDDCR_SOC_11
 - U18 VDDCR_SOC_12
 - U28 VDDCR_SOC_13
 - V16 VDDCR_SOC_14
 - W18 VDDCR_SOC_15
 - W20 VDDCR_SOC_16
 - Y19 VDDCR_SOC_17
 - T32 VDDIO_MEM_S3_1
 - V28 VDDIO_MEM_S3_2
 - W28 VDDIO_MEM_S3_3
 - W32 VDDIO_MEM_S3_4
 - Y23 VDDIO_MEM_S3_5
 - Y25 VDDIO_MEM_S3_6
 - Y28 VDDIO_MEM_S3_7
 - AA20 VDDIO_MEM_S3_8
 - AA23 VDDIO_MEM_S3_9
 - AA26 VDDIO_MEM_S3_10
 - AA28 VDDIO_MEM_S3_11
 - AA32 VDDIO_MEM_S3_12
 - AC30 VDDIO_MEM_S3_13
 - AC33 VDDIO_MEM_S3_14
 - AC25 VDDIO_MEM_S3_15
 - AC28 VDDIO_MEM_S3_16
 - AD23 VDDIO_MEM_S3_17
 - AD26 VDDIO_MEM_S3_18
 - AD29 VDDIO_MEM_S3_19
 - AD33 VDDIO_MEM_S3_20
 - AE20 VDDIO_MEM_S3_21
 - AE22 VDDIO_MEM_S3_22
 - AE25 VDDIO_MEM_S3_23
 - AE28 VDDIO_MEM_S3_24
 - AF23 VDDIO_MEM_S3_25
 - AF26 VDDIO_MEM_S3_26
 - AF28 VDDIO_MEM_S3_27
 - AF32 VDDIO_MEM_S3_28
 - AG20 VDDIO_MEM_S3_29
 - AG22 VDDIO_MEM_S3_30
 - AG25 VDDIO_MEM_S3_31
 - AG28 VDDIO_MEM_S3_32
 - AJ20 VDDIO_MEM_S3_33
 - AJ23 VDDIO_MEM_S3_34
 - AJ26 VDDIO_MEM_S3_35
 - AJ28 VDDIO_MEM_S3_36
 - AJ32 VDDIO_MEM_S3_37
 - AK28 VDDIO_MEM_S3_38
 - AL28 VDDIO_MEM_S3_39
 - AL32 VDDIO_MEM_S3_40
 - AP12 VDDIO_AUDIO
 - AL18 VDDIO_18_1
 - AM17 VDDIO_18_2
 - AL20 VDDIO_18_5S_1
 - AM19 VDDIO_18_5S_2
 - AL19 VDDIO_33_5S_1
 - AM18 VDDIO_33_5S_2
 - AL17 VDDVP_SS_1
 - AM16 VDDVP_SS_2
 - AL14 VDDVP_SS_3
 - AM15 VDDVP_1
 - AM12 VDDVP_2
 - AM13 VDDVP_3
 - AN12 VDDVP_4
 - AM14 VDDVP_5
 - AT11 VDD0BT_RTC_G

FP5 REV 0.90
PART 6 OF 13
AMD_RAVEN_RIDGE_FP5_BGA_1140P

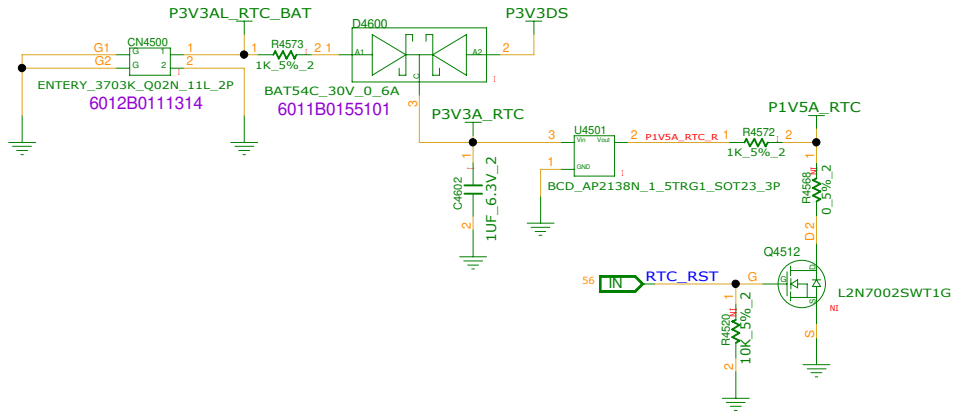

INVENTEC

TITLE				MODEL, PROJECT, FUNCTION	
Block Diagram				DOC NUMBER	
1310xxxx-0-0				REV	
X01				SHEET	
31 of 66					

CHANGE by	XXX	DATE	21-OCT-2002
PCB P/N	60xxxxxxxxxxx	PCB VER	XXX

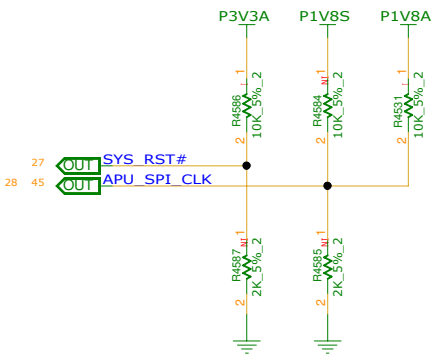

STRAP	DEFINITION
SPL_CLK	1: USE 48MHZ CRYSTAL CLOCK AND GENERATE BOTH INTERNAL AND EXTERNAL CLOCKS(DEFAULT) 0: USE 100MHZ PCIE CLOCK AS REFERENCE CLOCK AND GENERATE INTERNAL CLOCKS ONLY
SYS_RST#	1: NORMAL RESET MODE(DEFAULT) 0: SHORT RESET MODE

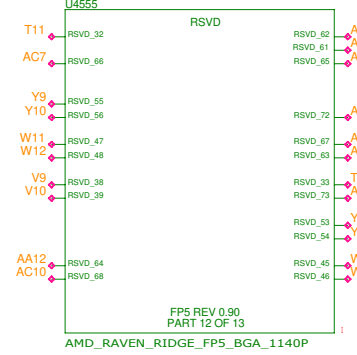
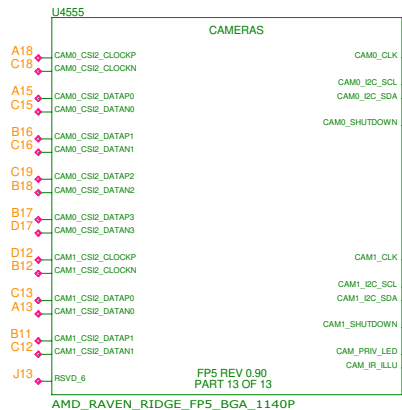
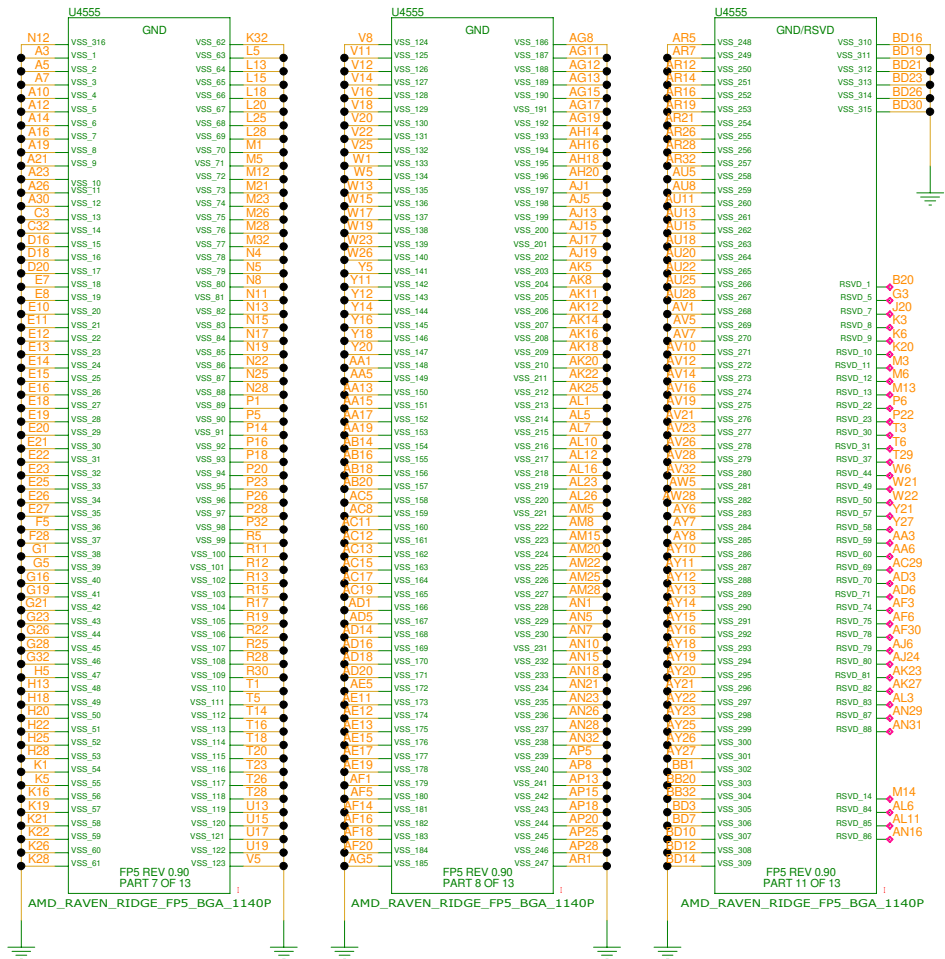

INVENTEC

TITLE: MODEM PCIE CONTROL FUNCTION

SIZE: A3 CODE: CS DOC NUMBER: 1310XXXX-0-0 REV: X01

SHEET: 32 of 66

CHANGE by	XXX	DATE	21-OCT-2002
PCB P/N	60XXXXXXXXXX	PCB VER	XXX

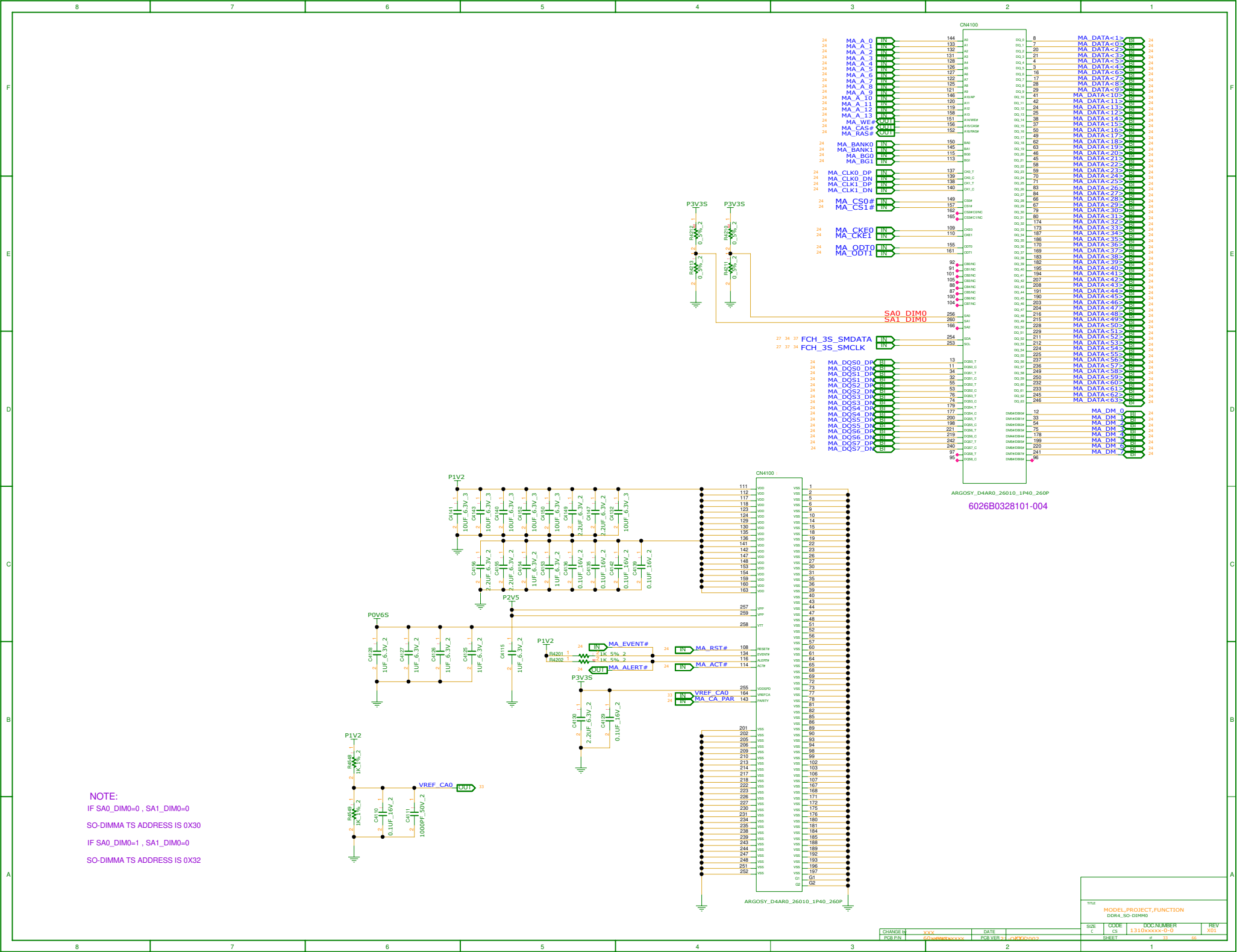

Pin	Signal Name	Direction	Internal Pin	Internal Name
24	MA_A_0	IN	144	AP
24	MA_A_1	IN	133	A1
24	MA_A_2	IN	132	A2
24	MA_A_3	IN	131	A3
24	MA_A_4	IN	128	A4
24	MA_A_5	IN	122	A5
24	MA_A_6	IN	127	A6
24	MA_A_7	IN	125	A7
24	MA_A_8	IN	121	A8
24	MA_A_9	IN	121	A9
24	MA_A_10	IN	146	AI0
24	MA_A_11	IN	120	A11
24	MA_A_12	IN	119	A12
24	MA_A_13	IN	158	A13
24	MA_A_14	IN	151	AI14WEF
24	MA_CAS#	IN	156	AI15CAS
24	MA_RAS#	IN	152	AI15RASP
24	MA_BANK0	IN	150	BA0
24	MA_BANK1	IN	145	BA1
24	MA_BG0	IN	115	BD0
24	MA_BG1	IN	113	BD1
24	MA_CLK0_DP	IN	137	CKL_T
24	MA_CLK0_DN	IN	138	CKL_C
24	MA_CLK1_DP	IN	138	CKL_T
24	MA_CLK1_DN	IN	140	CKL_C
24	MA_CS0#	IN	149	CSM
24	MA_CS1#	IN	157	CSM
24	MA_CS2#	IN	162	CSM
24	MA_CS3#	IN	165	CSM
24	MA_CS4#	IN	109	CSM
24	MA_CS5#	IN	110	CSM
24	MA_CS6#	IN	111	CSM
24	MA_CS7#	IN	155	CSM
24	MA_CS8#	IN	151	CSM
24	MA_CS9#	IN	82	CSM
24	MA_CS10#	IN	91	CSM
24	MA_CS11#	IN	101	CSM
24	MA_CS12#	IN	105	CSM
24	MA_CS13#	IN	88	CSM
24	MA_CS14#	IN	87	CSM
24	MA_CS15#	IN	100	CSM
24	MA_CS16#	IN	104	CSM
24	MA_CS17#	IN	94	CSM
24	MA_CS18#	IN	256	SAD
24	MA_CS19#	IN	166	SAD
24	MA_CS20#	IN	254	SAD
24	MA_CS21#	IN	253	SAD
24	MA_CS22#	IN	13	DS0
24	MA_CS23#	IN	11	DS0
24	MA_CS24#	IN	34	DS0
24	MA_CS25#	IN	32	DS0
24	MA_CS26#	IN	53	DS0
24	MA_CS27#	IN	55	DS0
24	MA_CS28#	IN	76	DS0
24	MA_CS29#	IN	74	DS0
24	MA_CS30#	IN	179	DS0
24	MA_CS31#	IN	177	DS0
24	MA_CS32#	IN	200	DS0
24	MA_CS33#	IN	198	DS0
24	MA_CS34#	IN	221	DS0
24	MA_CS35#	IN	219	DS0
24	MA_CS36#	IN	242	DS0
24	MA_CS37#	IN	240	DS0
24	MA_CS38#	IN	97	DS0
24	MA_CS39#	IN	95	DS0
24	MA_CS40#	IN	12	DM0
24	MA_CS41#	IN	33	DM0
24	MA_CS42#	IN	54	DM0
24	MA_CS43#	IN	75	DM0
24	MA_CS44#	IN	178	DM0
24	MA_CS45#	IN	199	DM0
24	MA_CS46#	IN	200	DM0
24	MA_CS47#	IN	241	DM0
24	MA_CS48#	IN	96	DM0

NOTE:
 IF SA0_DIM0=0, SA1_DIM0=0
 SO-DIMMA TS ADDRESS IS 0X30
 IF SA0_DIM0=1, SA1_DIM0=0
 SO-DIMMA TS ADDRESS IS 0X32

ARGOSY_D4AR0_26010_1P40_260P
 6026B0328101-004

CHANGE#	XXX	DATE	CODE	DOC NUMBER	REV
PCB.P/N	6026B0328101-004	PCB.VER.1	2	1313D000000-010	31
SIZE	C	SHEET	4	31	36

NOTE:
 SO-DIMM SPD ADDRESS IS 0X44
 SO-DIMM TS ADDRESS IS 0X34

REFERENCE NUMBER:4100~4299

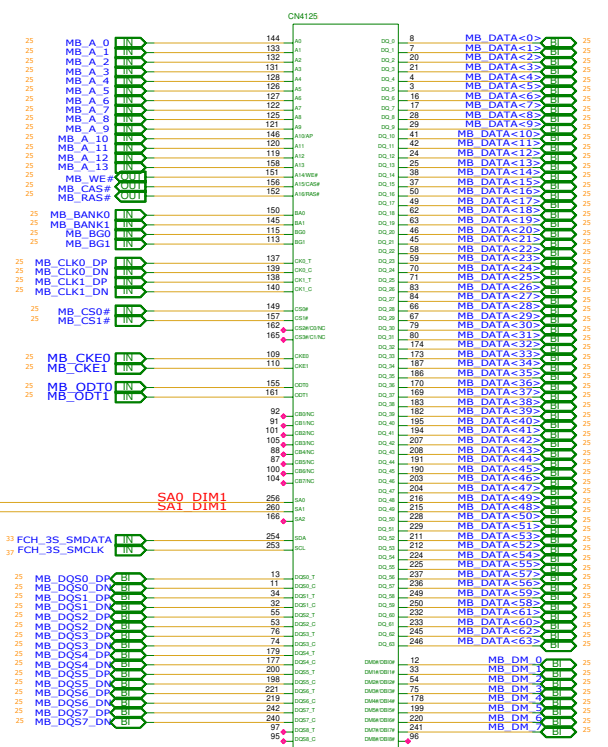
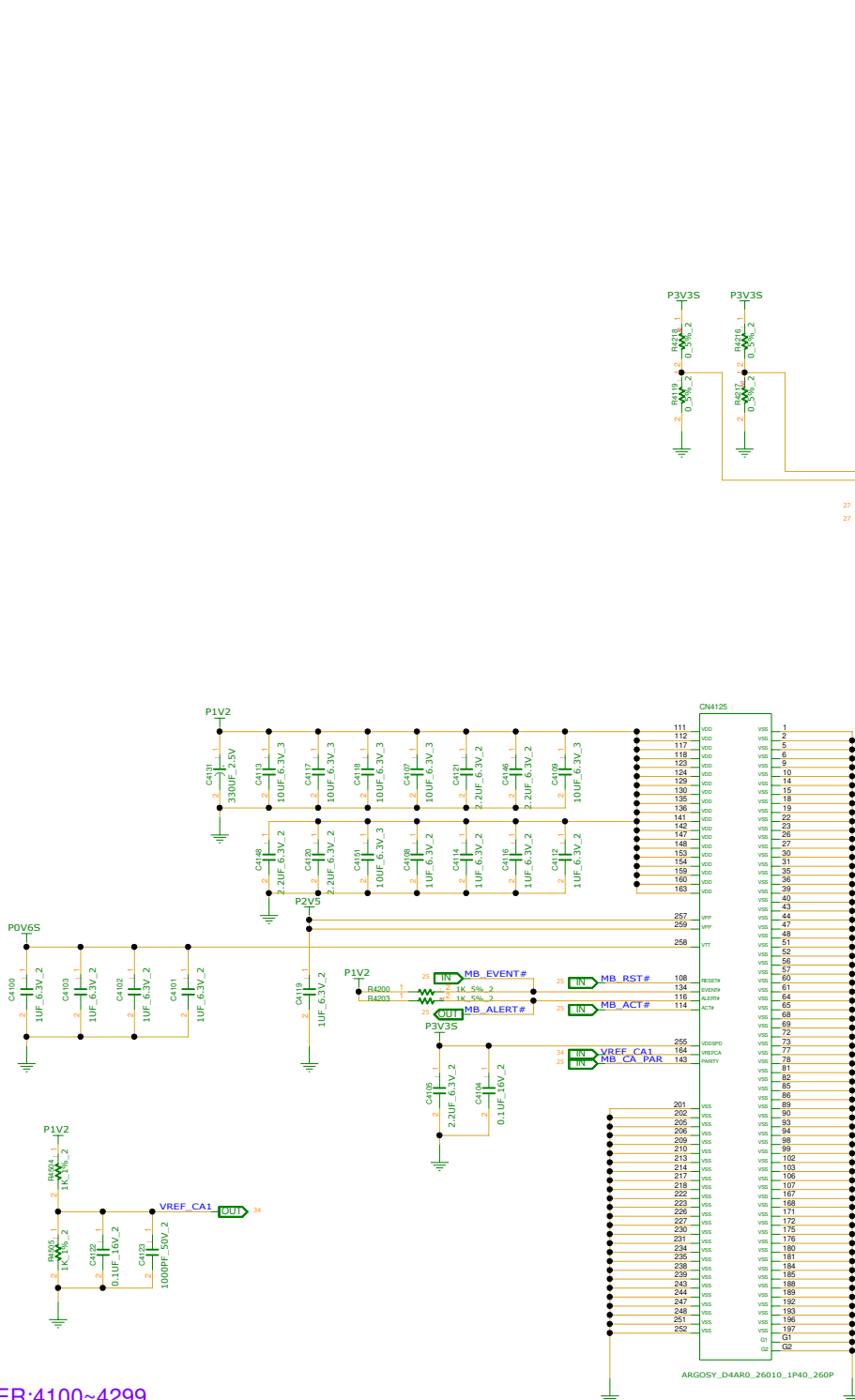

ARGOSY_D4AR0_26010_1P40_260P
 6026B0328101-004

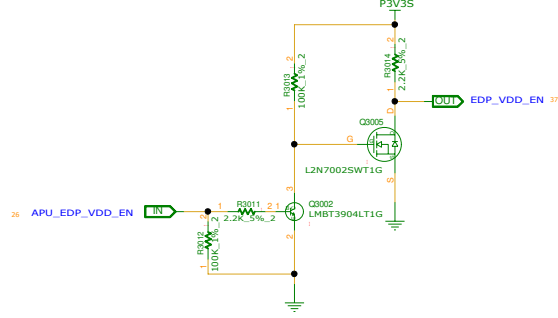
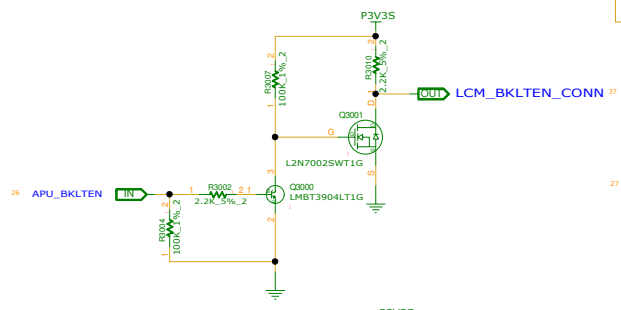
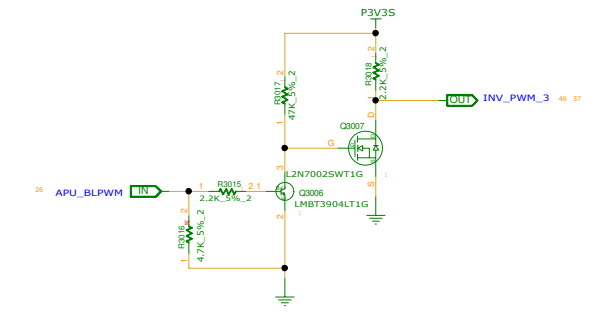
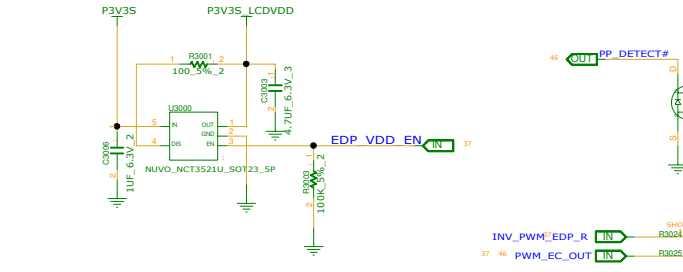

DP TO EDP LEVEL SHIFT

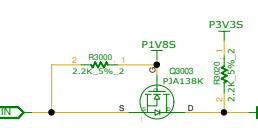
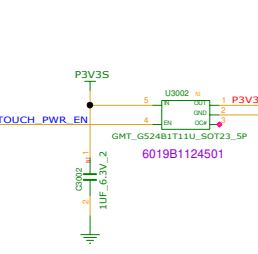
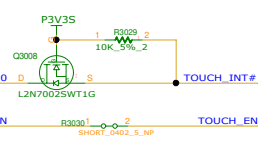
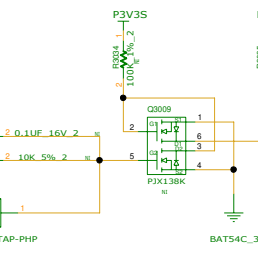
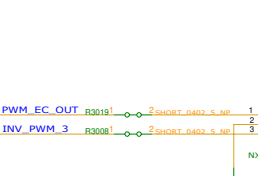
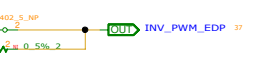
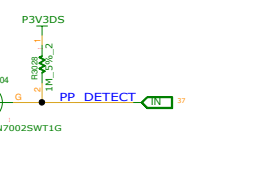

REFERENCE NUMBER:3000~3049

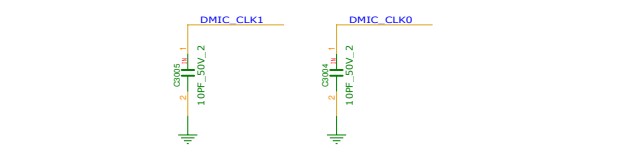
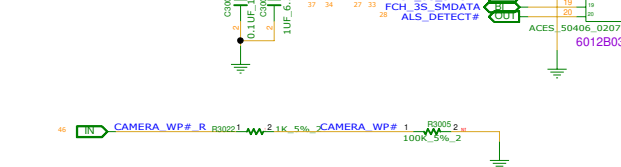
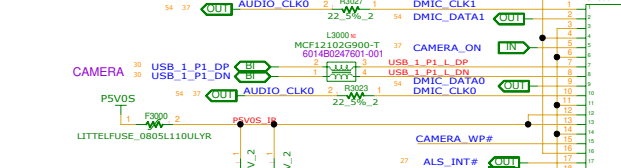
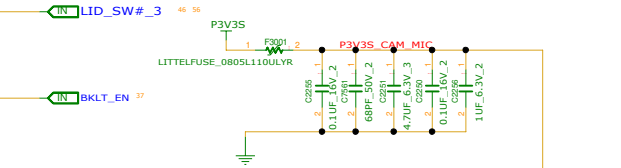
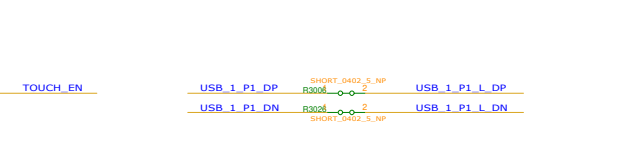
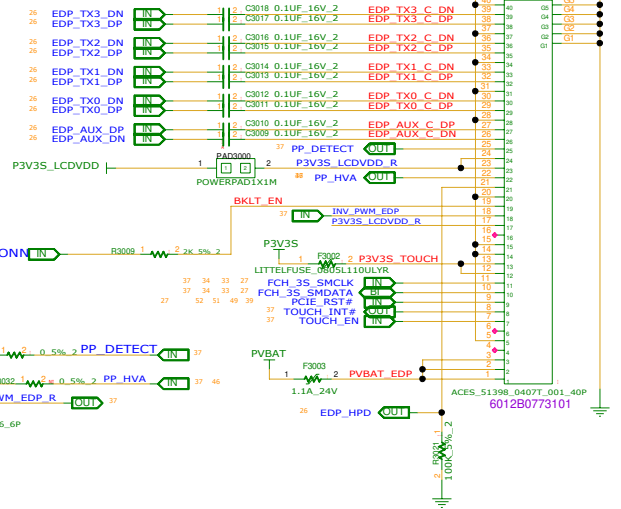

TITLE			
MODEL_PROJECT_FUNCTION			
Block Diagram			
SIZE	CODE	DOCNUMBER	REV
A5	65	1310XXXX-0-0	X01
SHEET	37	of 66	

CHANGE#	XXX	DATE	21-OCT-2002
PCB/PIN	6PXXXXXXXXXX	PCB/VER	XXX

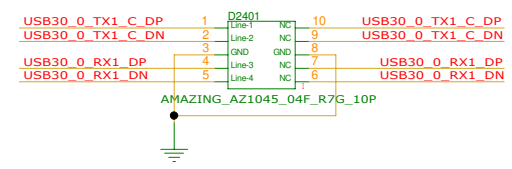
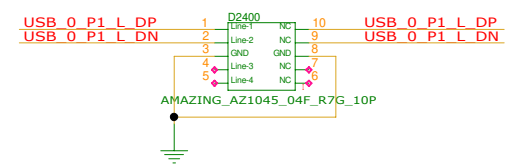
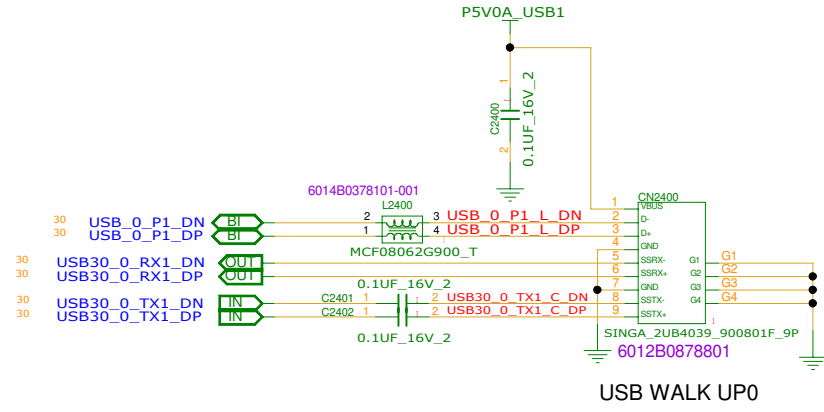
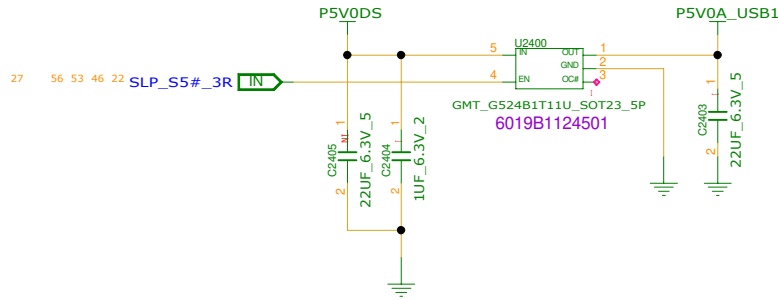

REFERENCE NUMBER:2400~2499

INVENTEC			
TITLE MODEL,PROJECT,FUNCTION USB			
SIZE A3	CODE CS	DOC NUMBER 1310xxxxx-0-0	REV X01
CHANGE by PCB P/N		DATE PCB VER	21-OCT-2002 XXX
SHEET		40 of 66	

CHANGE by	XXX	DATE	21-OCT-2002
PCB P/N	60xxxxxxxxxxx	PCB VER	XXX

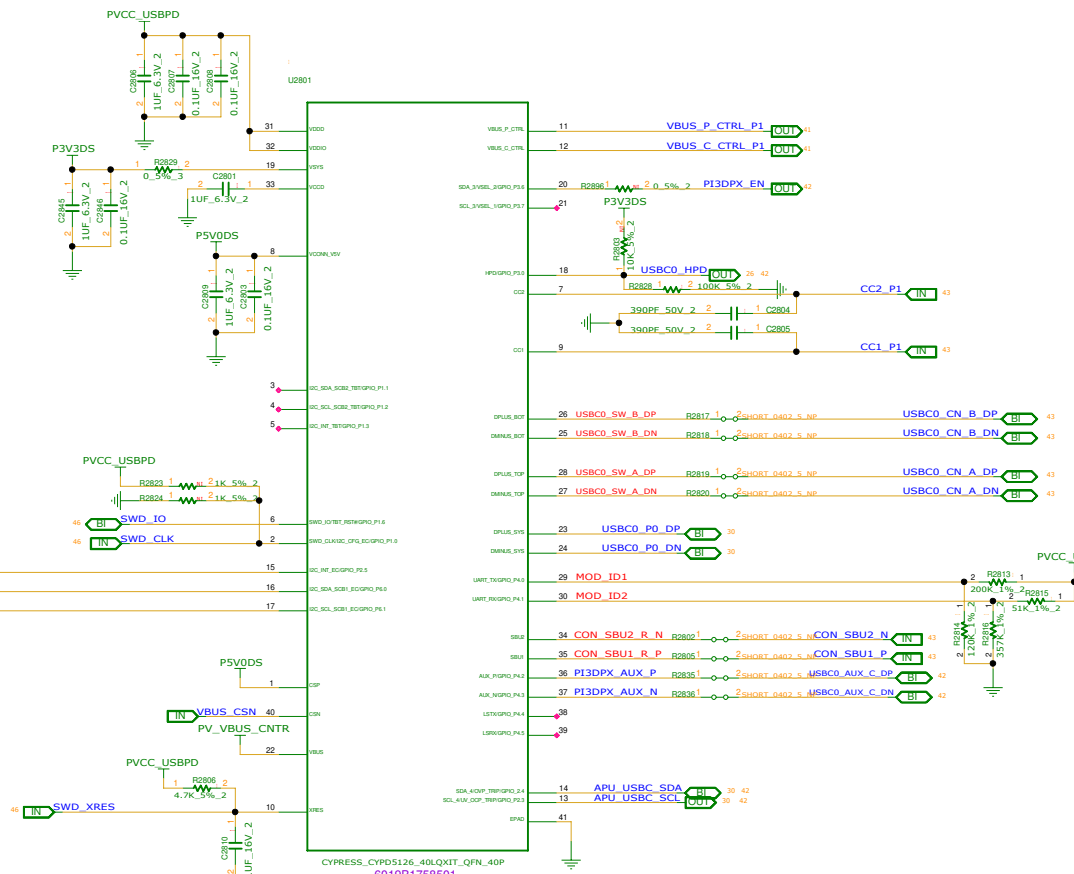

$MOD_ID1 = L3 = 3 \cdot VDD8 / 8 = 1.2375V$
 $MOD_ID2 = L7 = 7 \cdot VDD8 / 8 = 2.8875V$

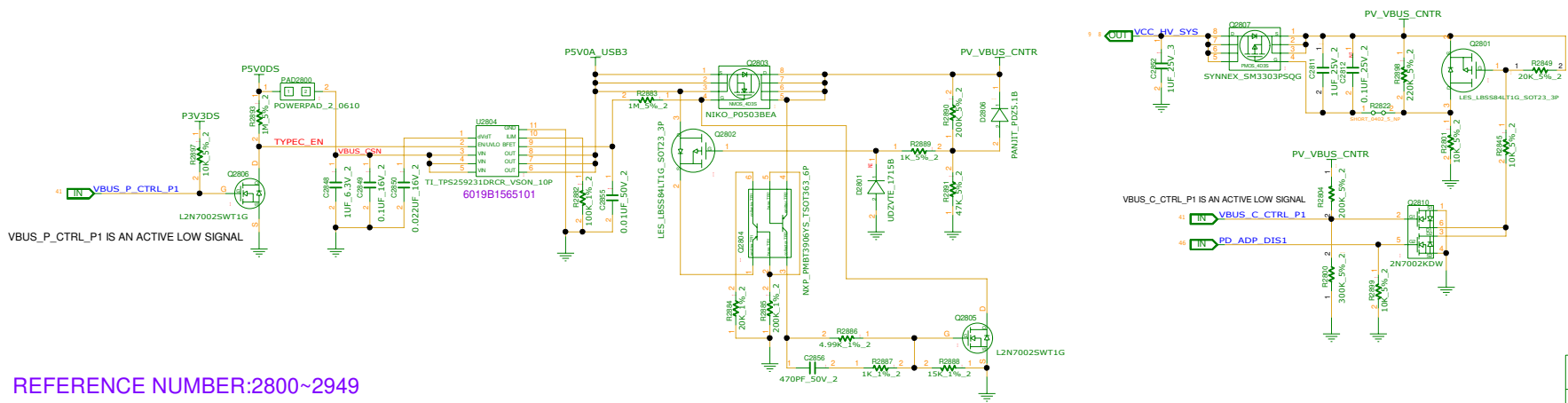

REFERENCE NUMBER:2800~2949
USB-C PD CONTROLLER

CHANGE#	XXX	DATE	21-OCT-2002	TITLE	MODEL,PROJECT,FUNCTION	SIZE	CODE	DOCNUMBER	REV
PCB PIN	60XXXXXXXXXX	PCB VER	XXX	Block Diagram		AS	1310XXXXXX-2-0		X01
SHEET	41						of 66		

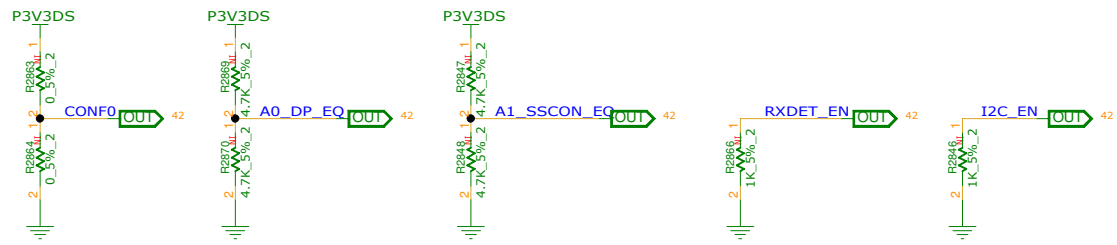
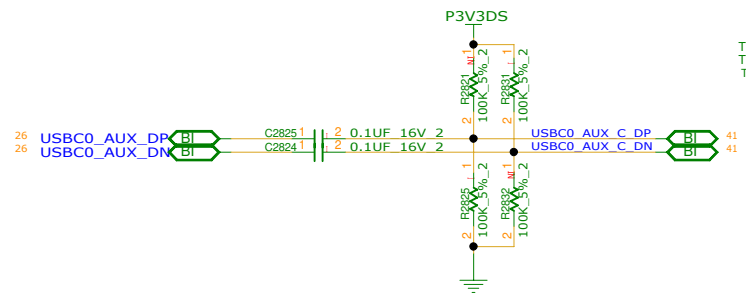
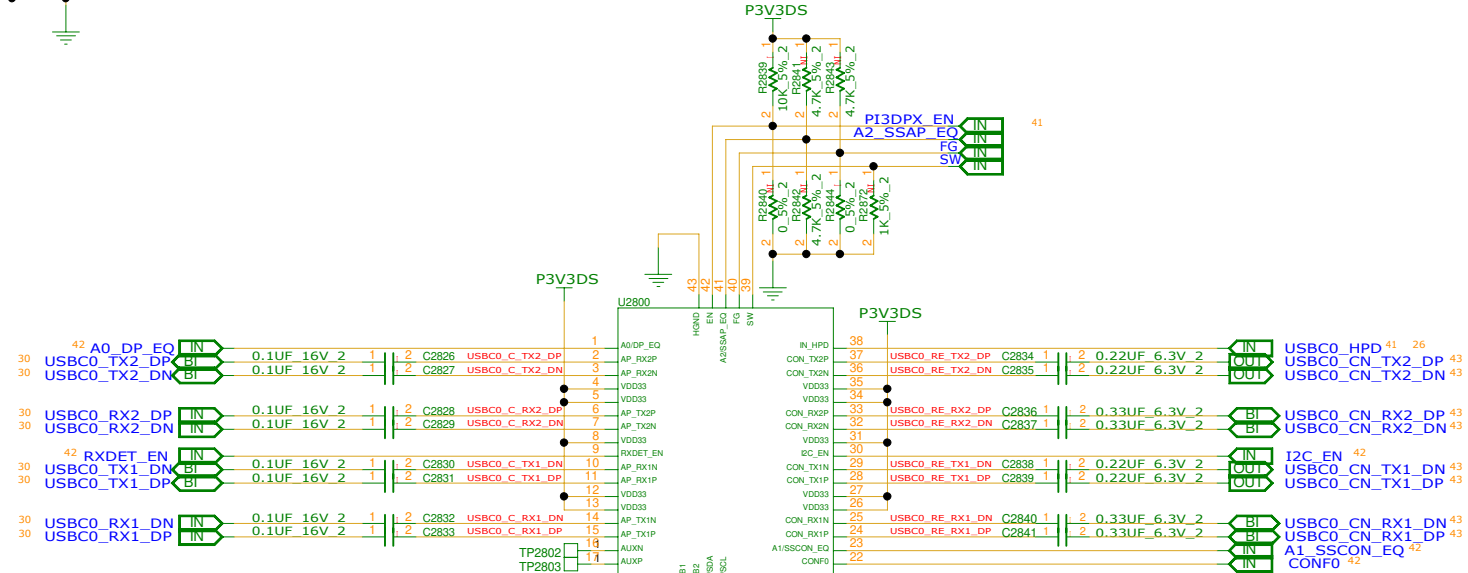
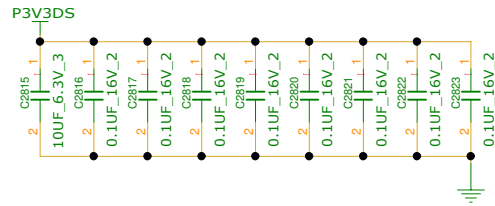

INVENTEC

TITLE: MODEL,PROJECT,FUNCTION
Block Diagram

SIZE A3 CODE CS DOC NUMBER 1310xxxx-0-0 REV X01

SHEET 42 of 66

CHANGE by	XXX	DATE	21-OCT-2002
PCB P/N	60xxxxxxxxxxx	PCB VER	XXX

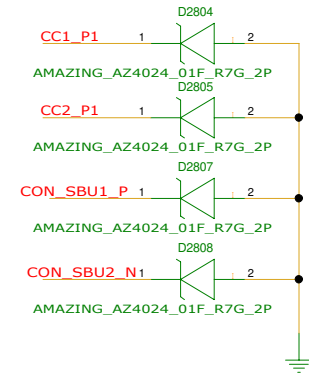
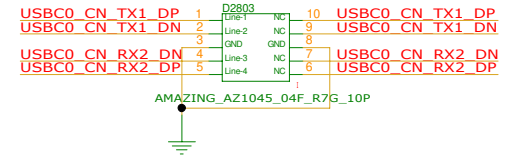
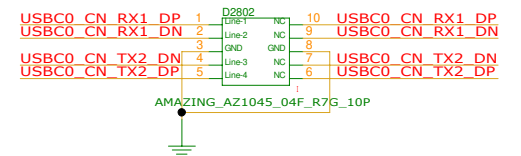
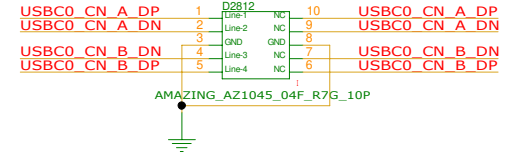
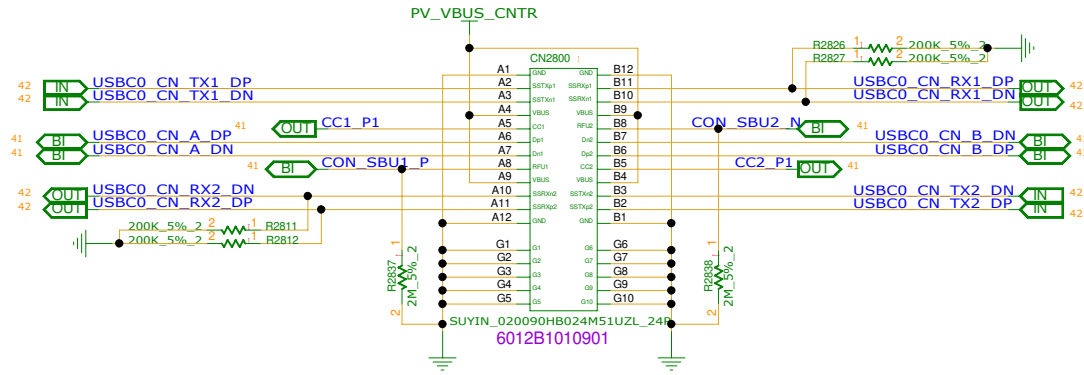
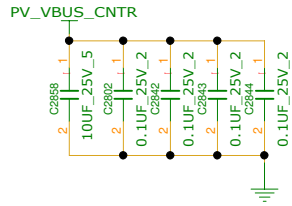

USB TYPE C

REFERENCE NUMBER:2800 ~ 2949

INVENTEC			
TITLE			
MODEL PROJECT FUNCTION			
USB TYPE-C_CNTR			
SIZE	CODE	DOC NUMBER	REV
A3	CS	1310xxxx-0-0	X01
SHEET		43 of 66	

CHANGE by	XXX	DATE	21-OCT-2002
PCB P/N	60xxxxxxxxxx	PCB VER	XXX

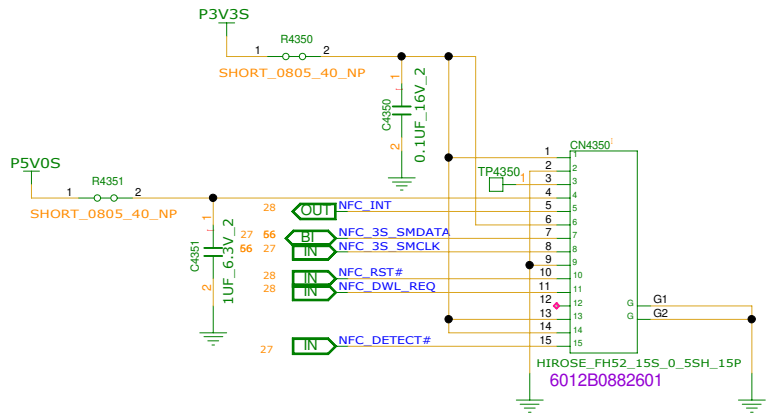

NFC MODULE CNTR

REFERENCE NUMBER : 4350~4399

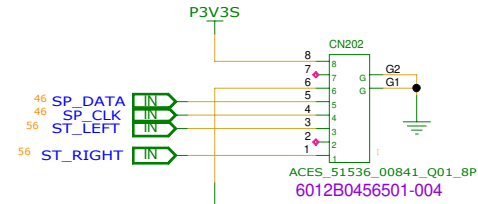

POINT STICK CNTR

REFERENCE NUMBER : 200~299

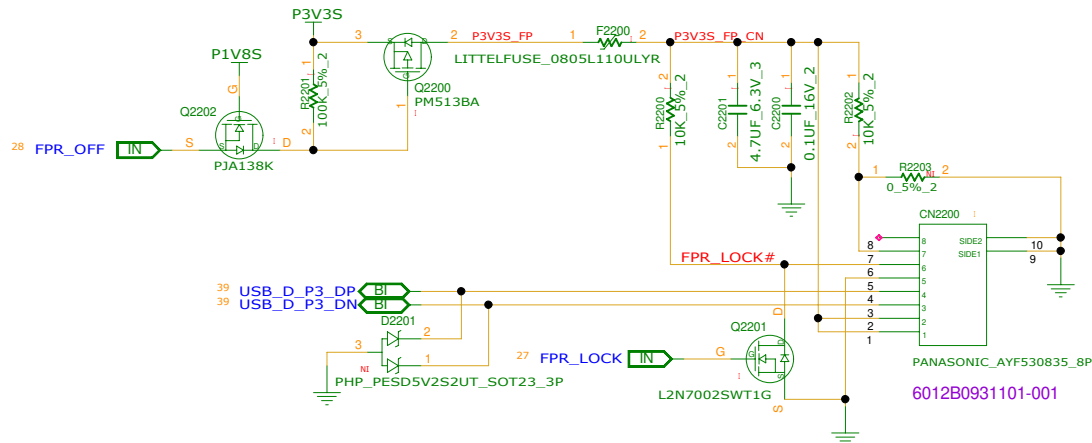

FINGER PRINT CNTR

REFERENCE NUMBER : 2200~2249

INVENTEC			
TITLE MINI PRINTER & NFC FUNCTION			
SIZE A3	CODE CS	DOC NUMBER 1310xxxxx-0-0	REV X01
SHEET 44 of 66			

CHANGE by PCB P/N	XXX 60xxxxxxxxxxx	DATE PCB VER	21-OCT-2002 XXX
----------------------	----------------------	-----------------	--------------------

SPI FLASH

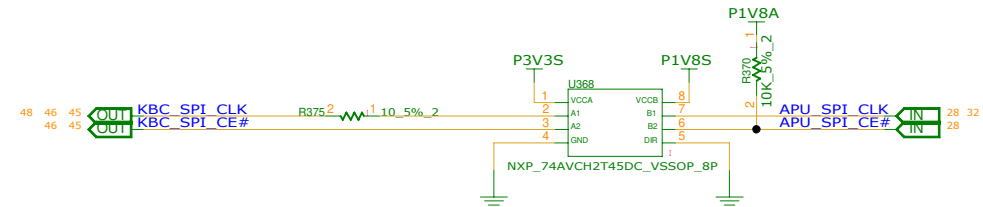
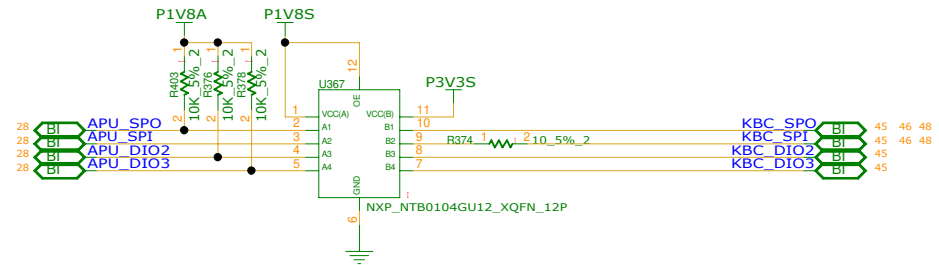
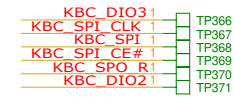
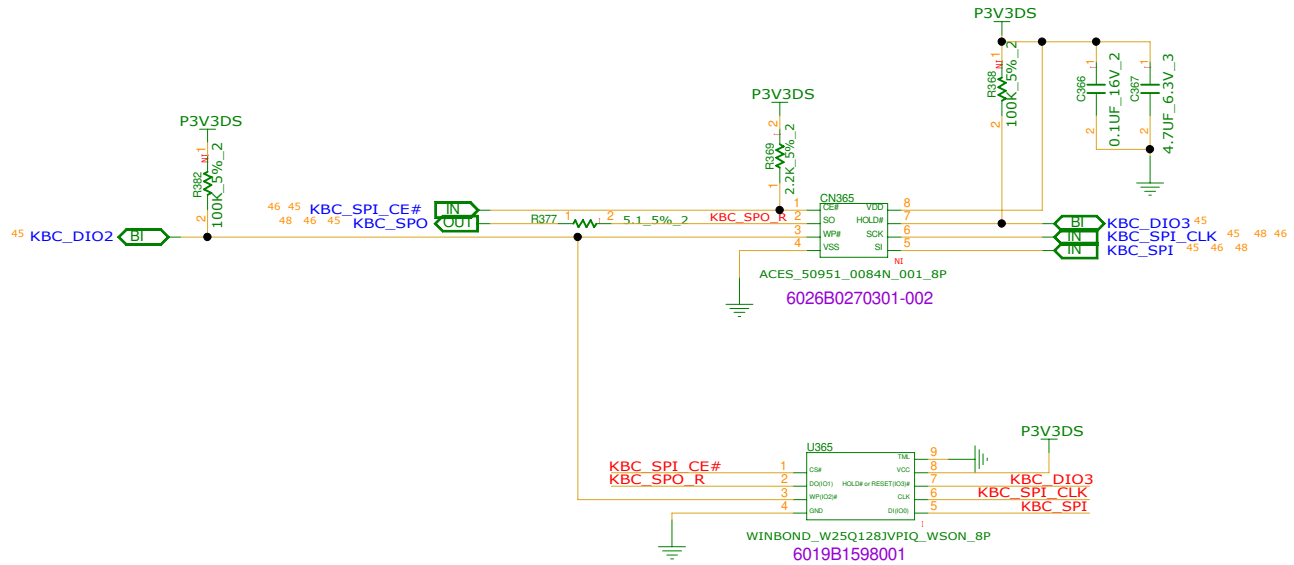

INVENTEC			
TITLE MODEL, PROJECT, FUNCTION			
BIOS			
SIZE A3	CODE CS	DOC NUMBER 1310xxxx-0-0	REV X01
CHANGE by XXX		DATE 21-OCT-2002	
PCB P/N 60xxxxxxxxxxx		PCB VER XXX	
SHEET 45 of 66			

REFERENCE NUMER : 300~399

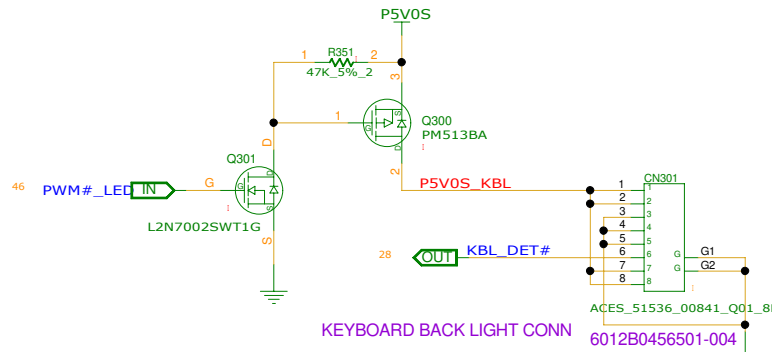
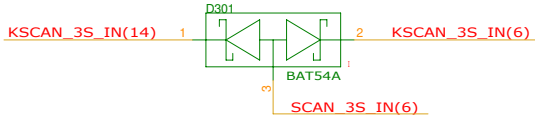
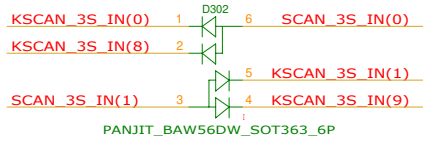
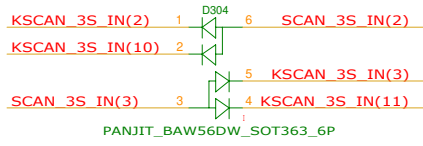
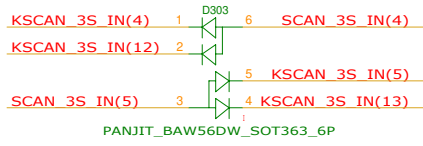
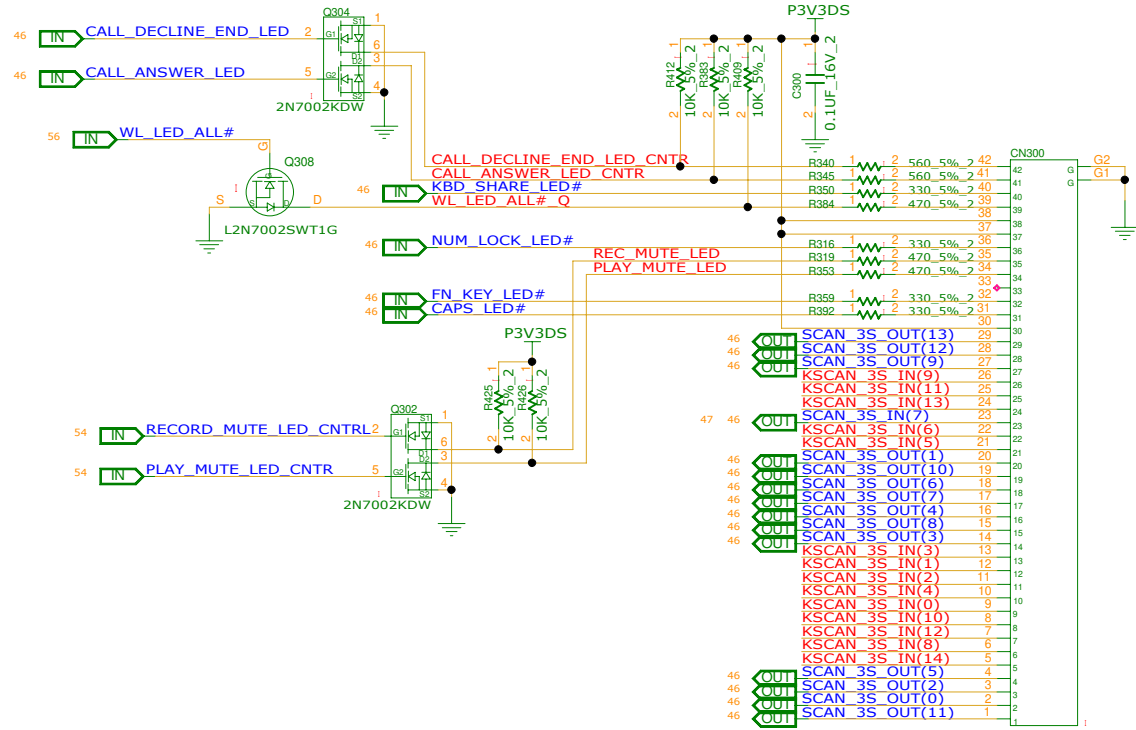
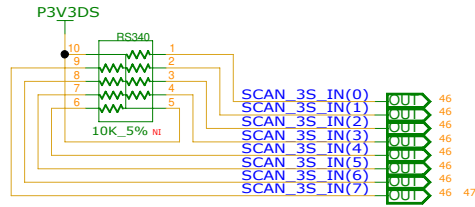

NOTE:
KBL_DET# FOR KEYBOARD LIGHT DETECT

CHANGE by	XXX	DATE	21-OCT-2002
PCB P/N	60xxxxxxxxxxx	PCB VER	XXX

INVENTEC

TITLE: KEYBOARD
 MODIFIED PROJECT, FUNCTION

SIZE A3 CODE CS DOC NUMBER 1310xxxx-0-0 REV X01
 SHEET 47 of 66

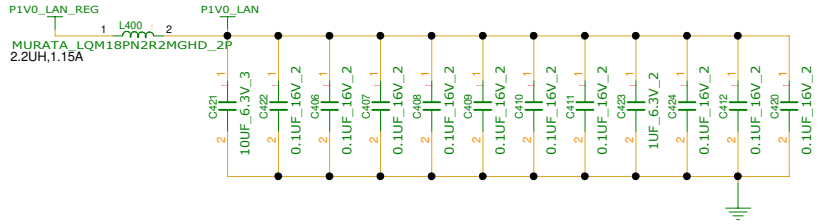

P3V3_LAN RISING TIME 0.5MS~100MS

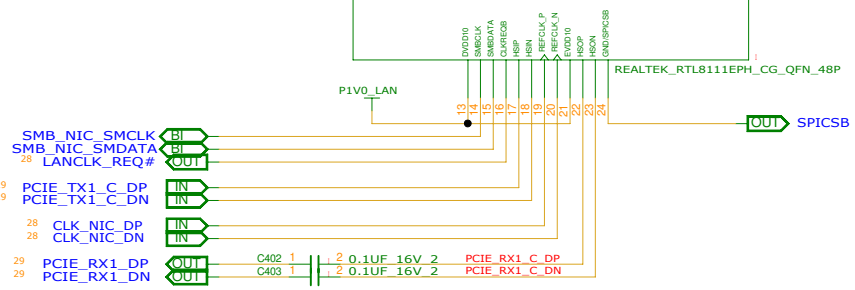
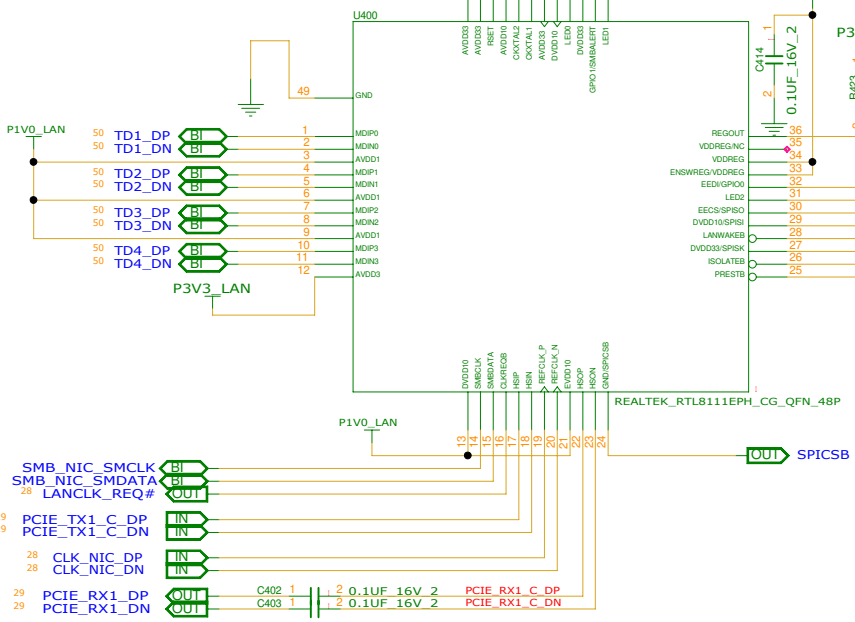
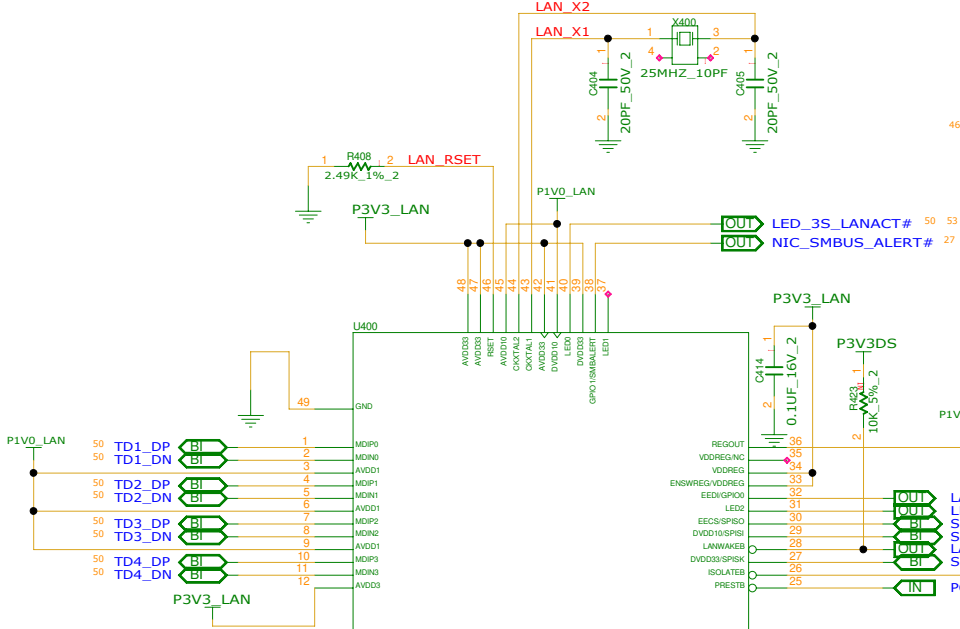
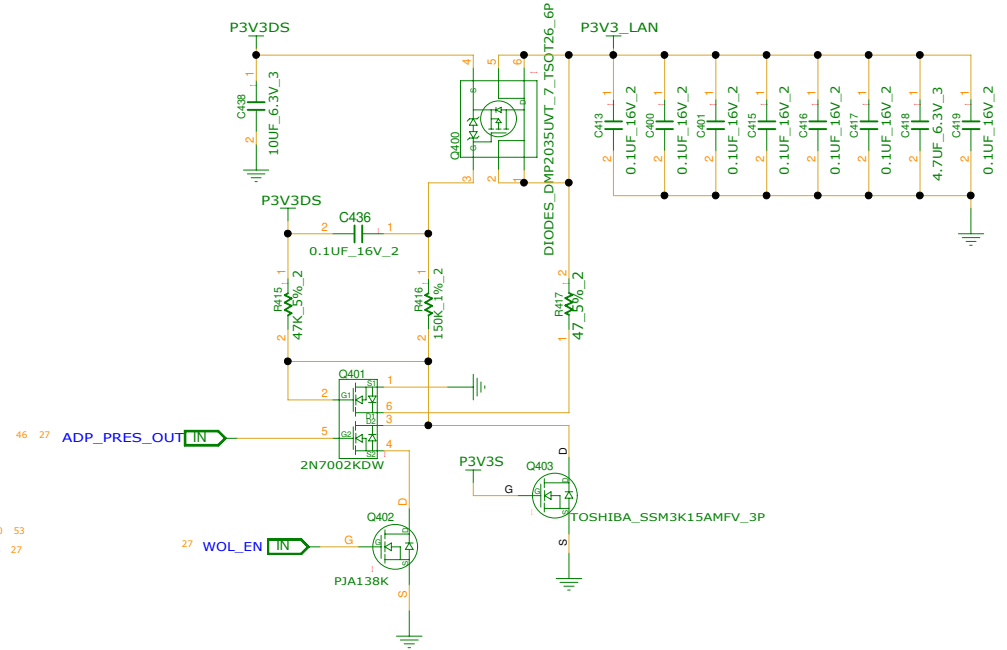

REFERENCE NUMBER : 400~469

INVENTEC			
TITLE MODEL, PROJECT, FUNCTION Block Diagram			
SIZE A3	CODE CS	DOC NUMBER 1310xxxxx-0-0	REV X01
SHEET 49 of 66			

CHANGE by	XXX	DATE	21-OCT-2002
PCB PIN	60xxxxxxxxxxx	PCB VER	XXX

TRANSFORMER & RJ45 CONN

REFERENCE NUMER : 470~499

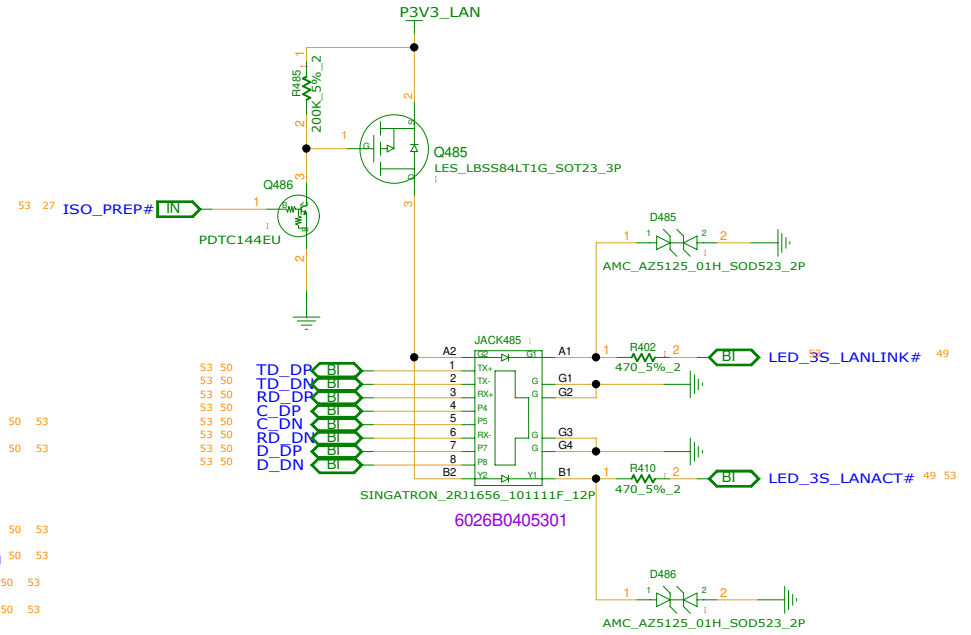
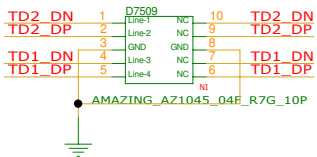
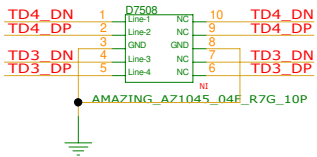
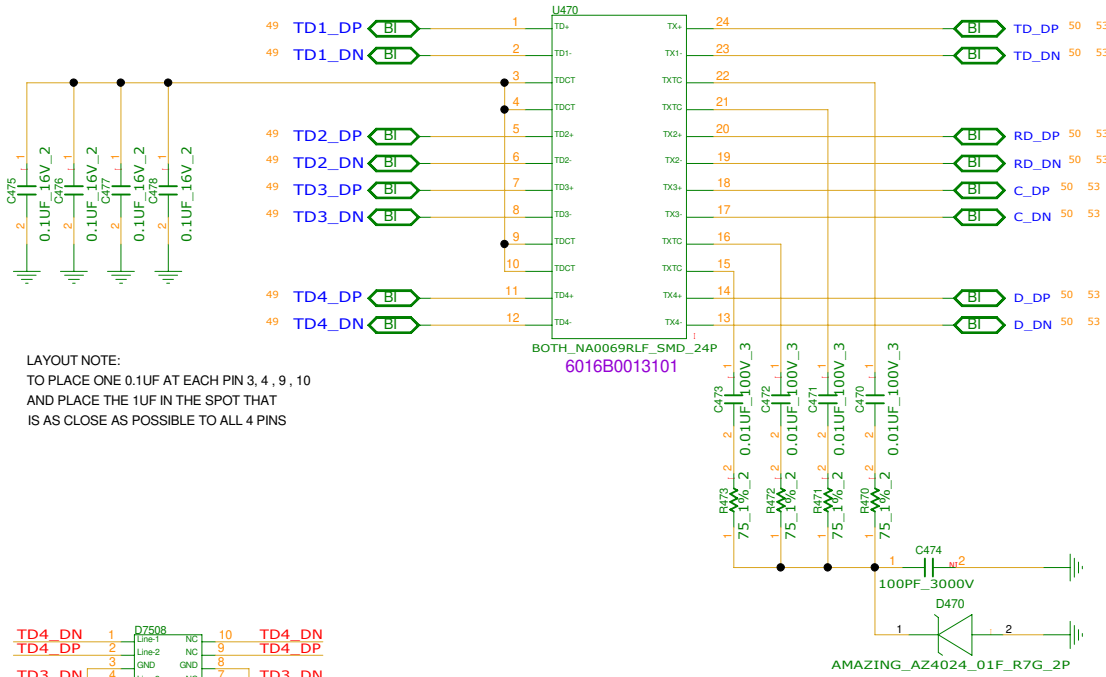

CHANGE by	XXX	DATE	21-OCT-2002
PCB P/N	60xxxxxxxxxxx	PCB VER	XXX

INVENTEC			
TITLE MODEL PROJECT FUNCTION TRANSFORMER & RJ45			
SIZE A3	CODE CS	DOC NUMBER 1310xxxxx-0-0	REV X01
SHEET		50 of 66	

REFERENCE NUMBER:1400~1499

6026B0243101-006
KEY B TYPE
M.2 WWAN

INVENTEC

TITLE
MODEM WWAN KEY B, FUNCTION

SIZE A3	CODE CS	DOC NUMBER 1310xxxxx-0-0	REV X01
SHEET		52 of 66	

CHANGE by	XXX	DATE	21-OCT-2002
PCB P/N	60xxxxxxx	PCB VER	XXX

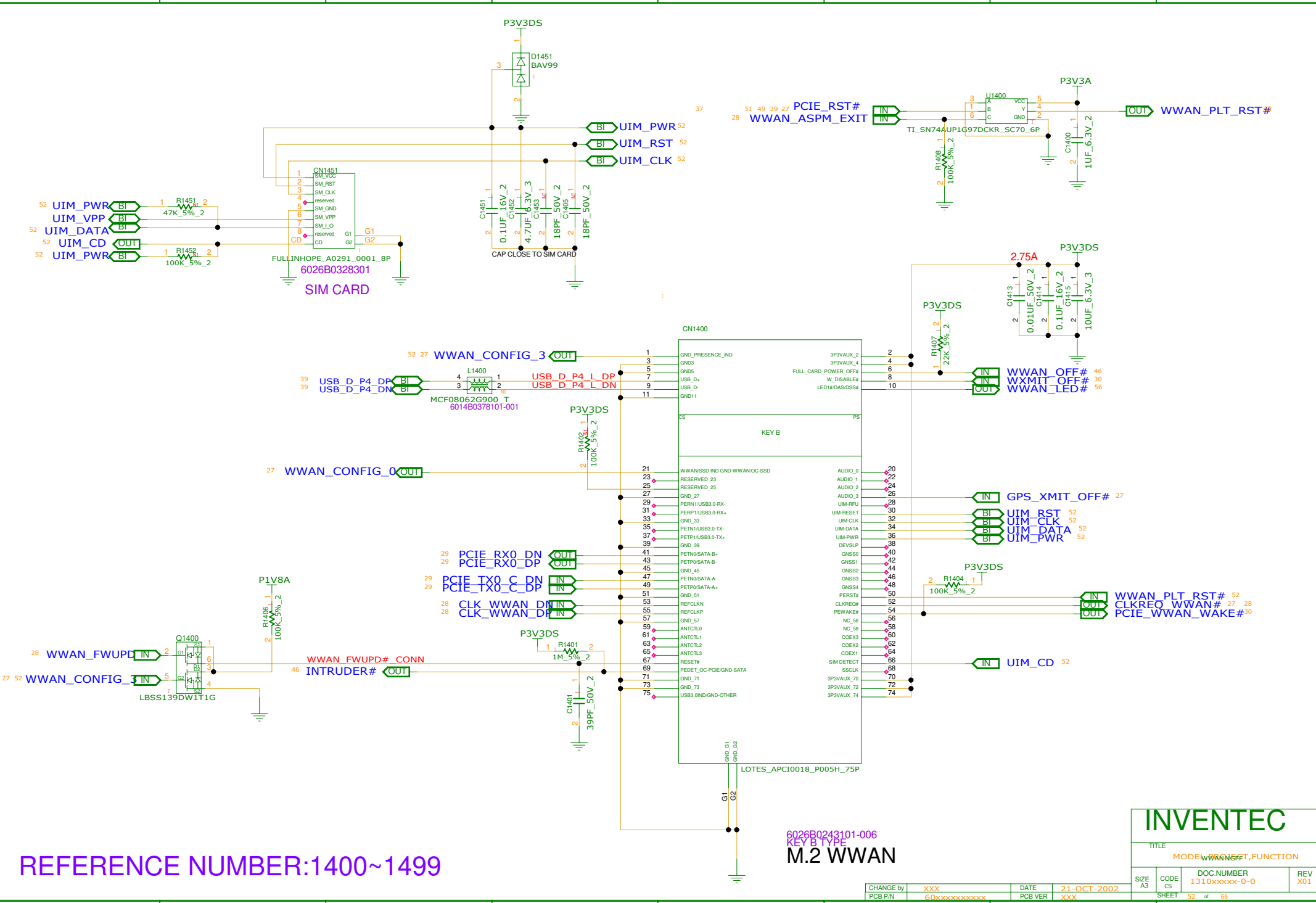

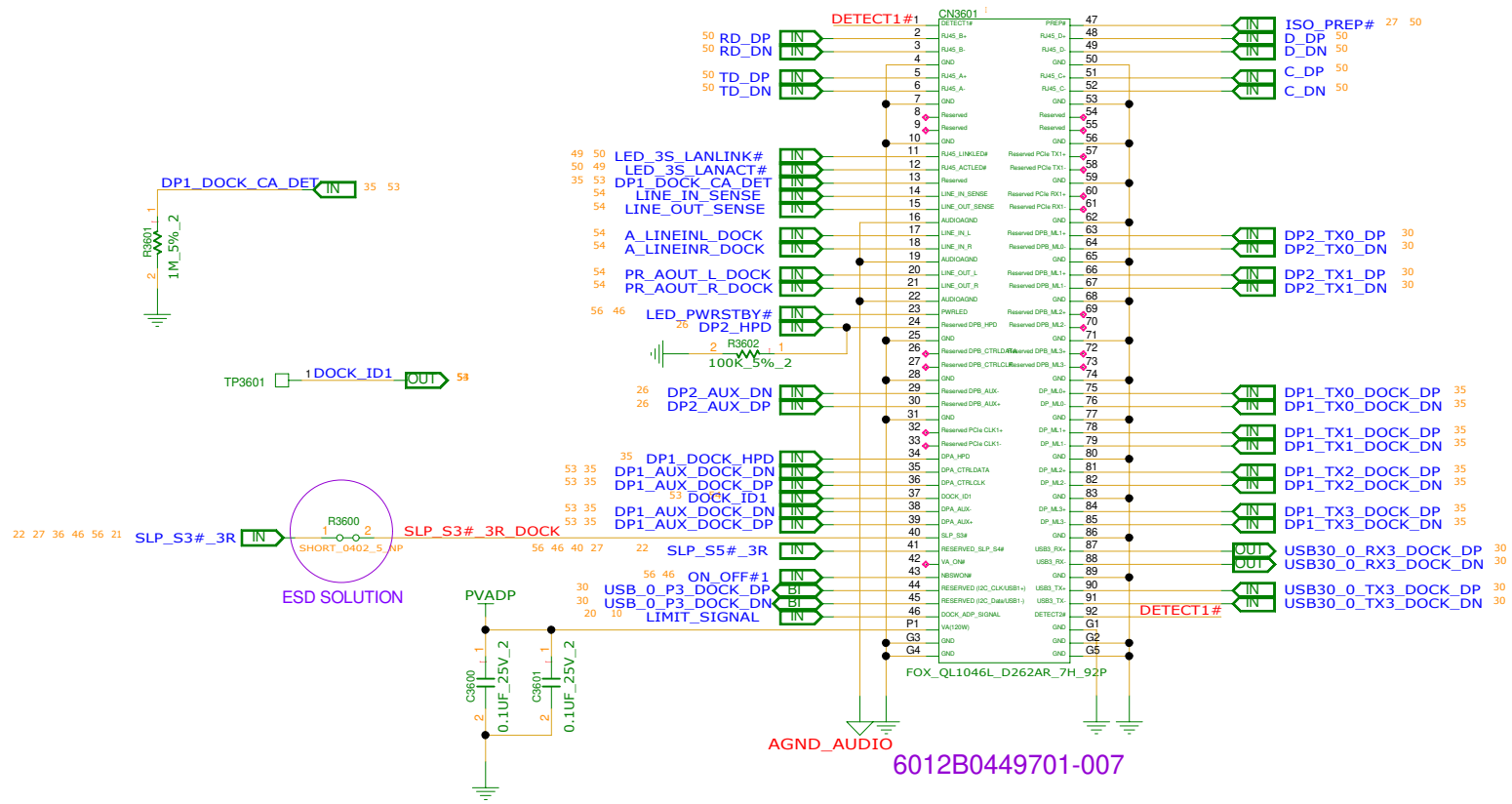

6012B0449701-007

INVENTEC

TITLE: MODEL PROJECT,FUNCTION
DOCKING_CNTR

SIZE A3 CODE CS DOCNUMBER 1310xxxx-0-0 REV X01

SHEET 53 of 66

CHANGE by	XXX	DATE	21-OCT-2002
PCB P/N	60xxxxxxxxxxx	PCB VER	XXX

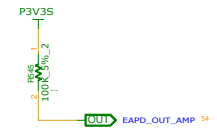
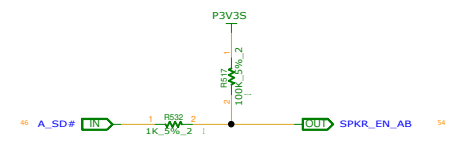
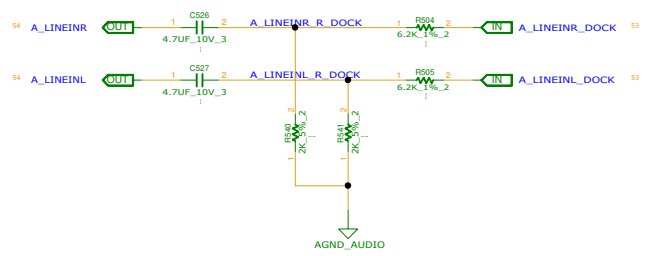
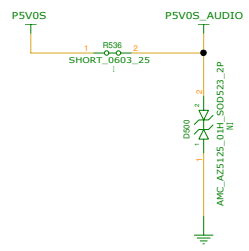

ANALOG

DIGITAL

ANALOG

DIGITAL

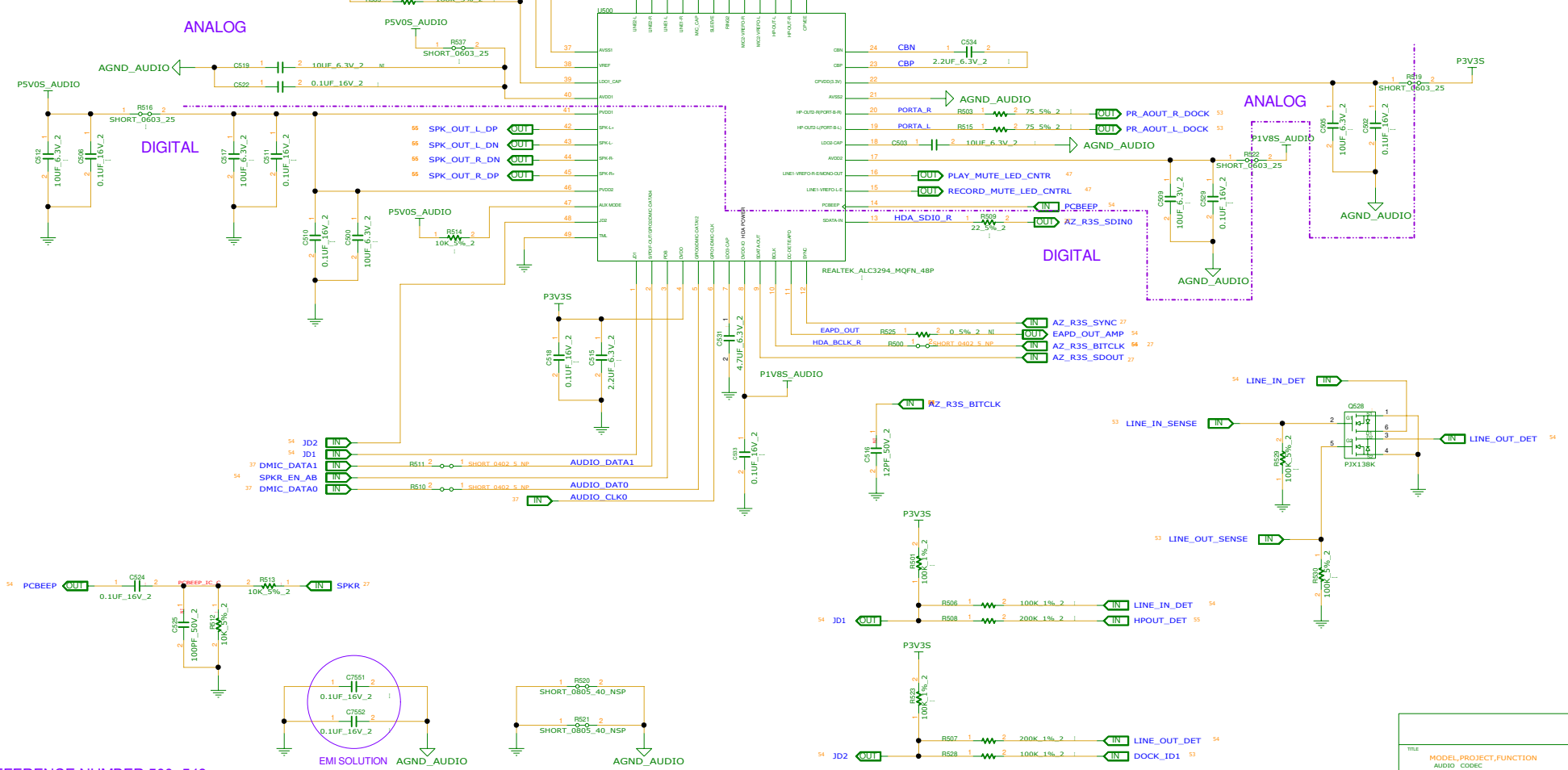

REFERENCE NUMBER:500~549

EMI SOLUTION AGND_AUDIO

AGND_AUDIO

CHANGE#	XXX	DATE	21-OCT-2002	SIZE	CODE	DOCNUMBER	REV
PCB PIN	6Dxxxxxxxxxx	PCB VER	XXX	A5	63	1310xxxxx-2-0	X01
				SHEET	54	of 66	

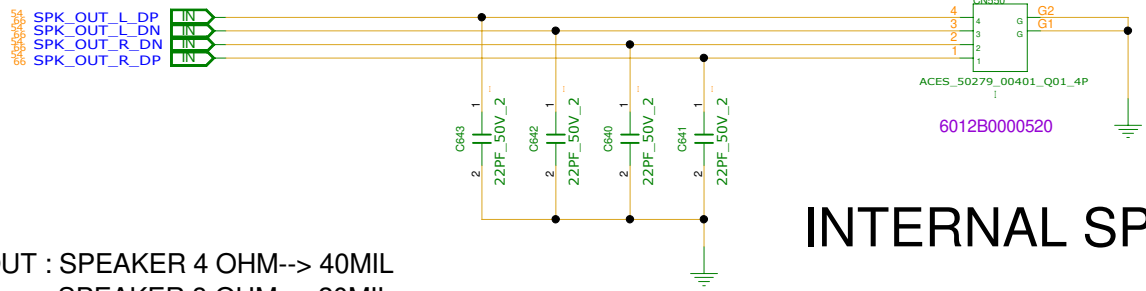

INTERNAL SPEAKER

LAYOUT : SPEAKER 4 OHM--> 40MIL
SPEAKER 8 OHM--> 20MIL

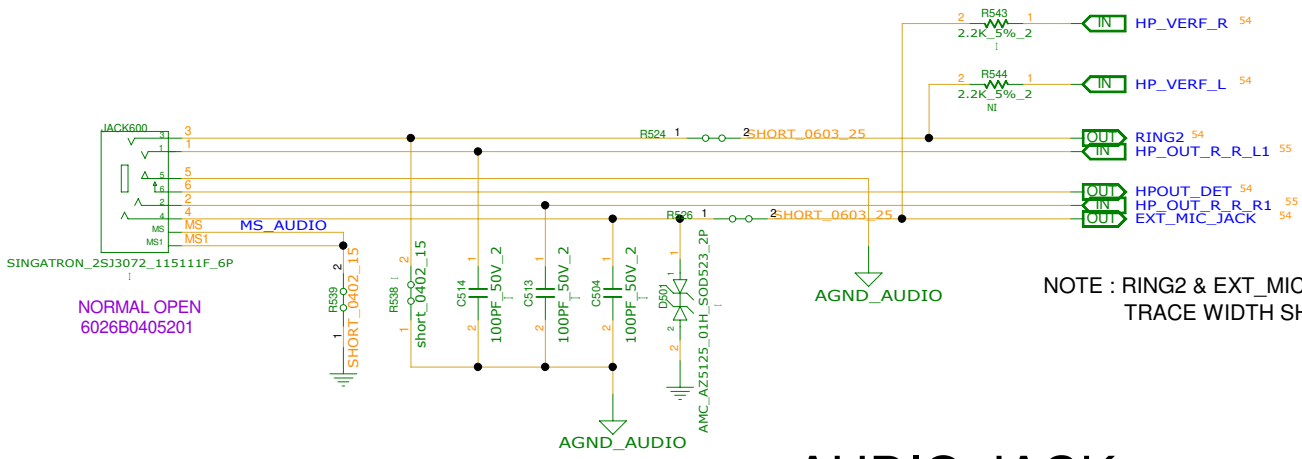

NOTE : RING2 & EXT_MIC_JACK
TRACE WIDTH SHOULD BE 40MIL LEAST

AUDIO JACK

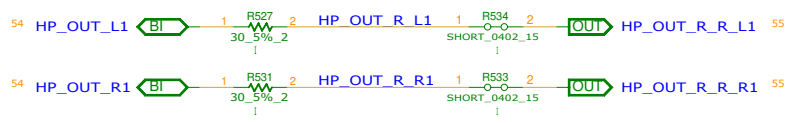

REFERENCE NUMBER:600~649

INVENTEC			
TITLE MODEL,PROJECT,FUNCTION SPEAKER			
SIZE A3	CODE CS	DOC.NUMBER 1310xxxx-0-0	REV X01
CHANGE by PCB P/N		DATE PCB VER	21-OCT-2002 XXX
SHEET		55 of 66	

REFERENCE NUMBER:100~199

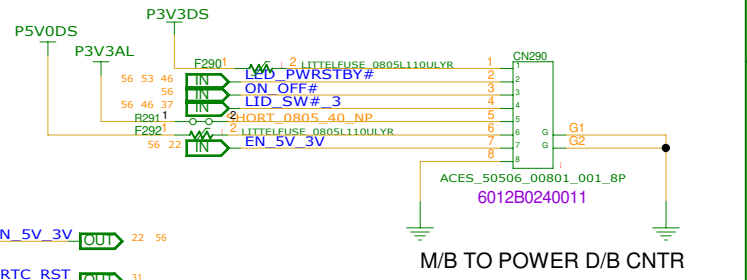
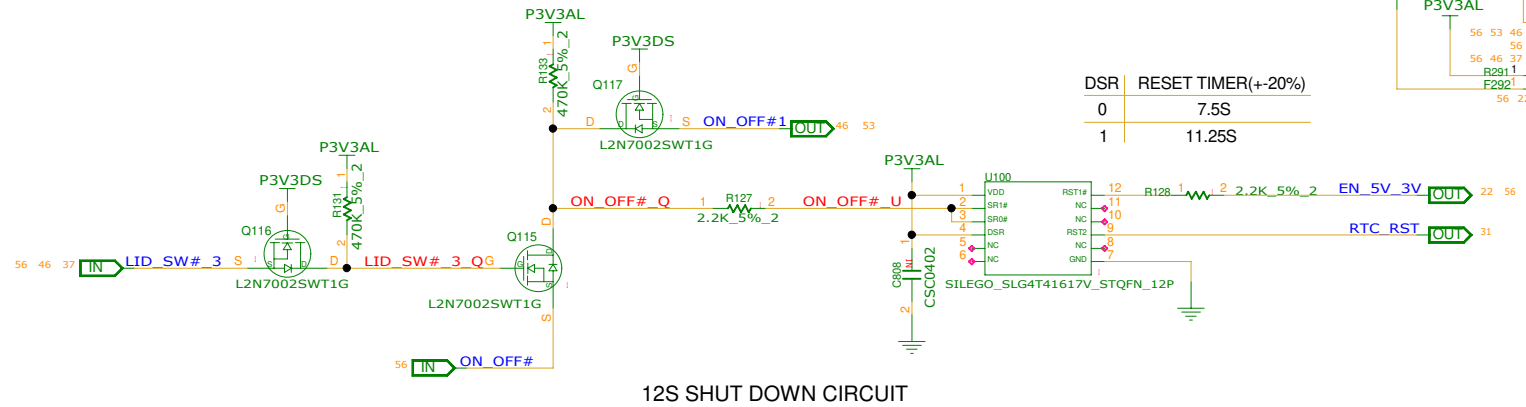
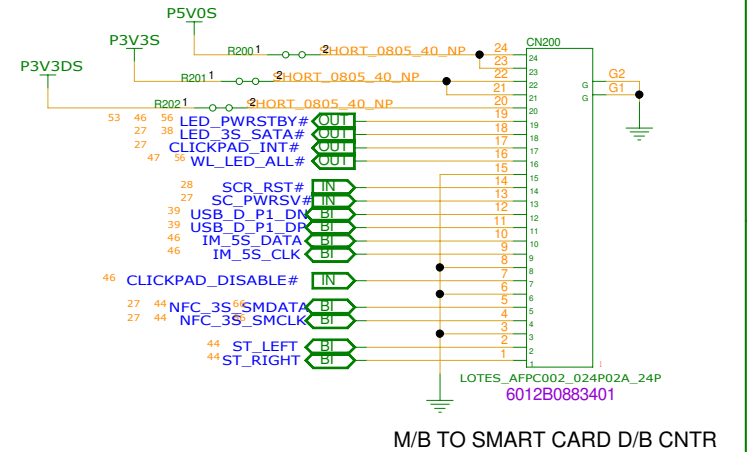
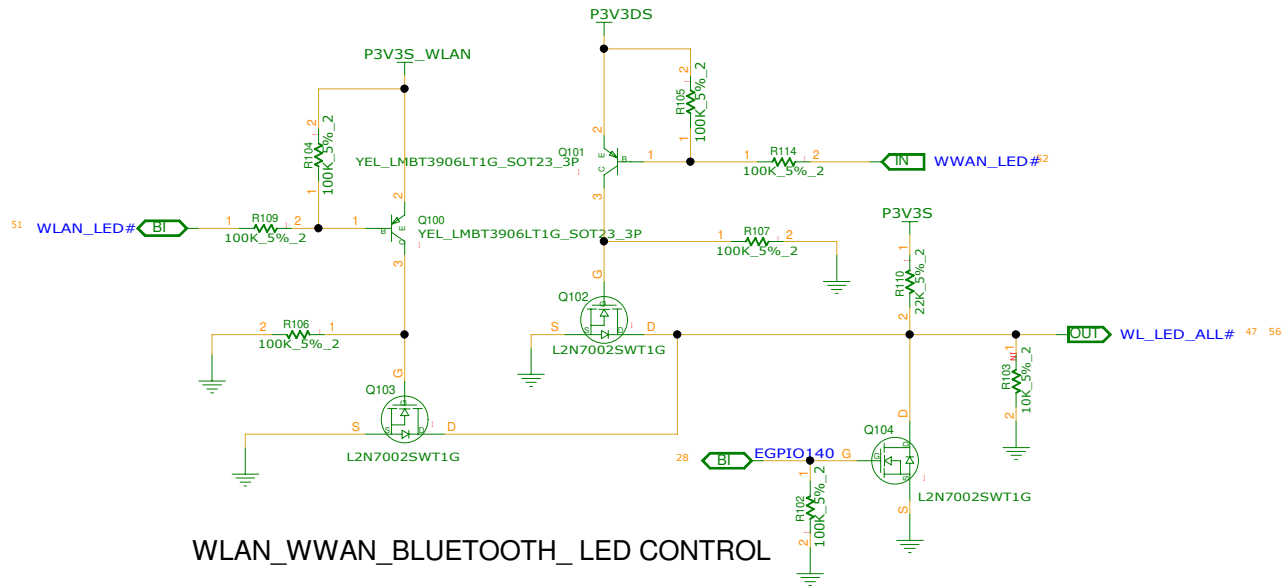
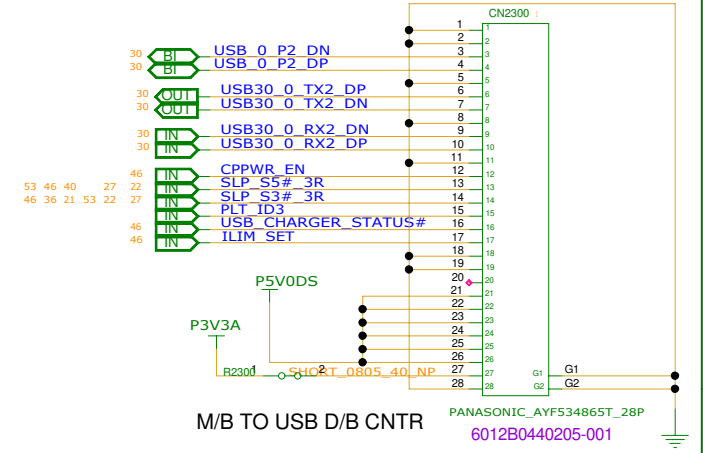
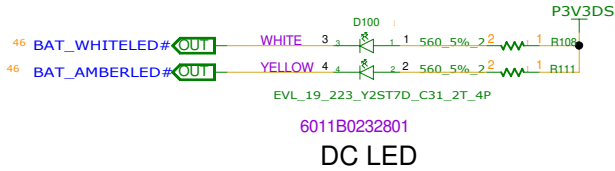

INVENTEC

TITLE			
512R2EL01NPJ&C2B1CNTR10N			
SIZE	CODE	DOC. NUMBER	REV
A3	CS	1310xxxxx-0-0	X01
SHEET		56 of 66	

CHANGE by	XXX	DATE	21-OCT-2002
PCB PIN	60xxxxxxxxxxx	PCB VER	XXX

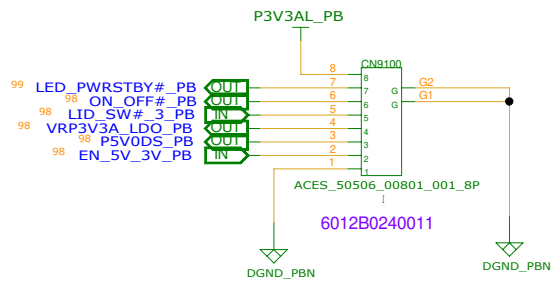

AMBIENT TEMP SENSE

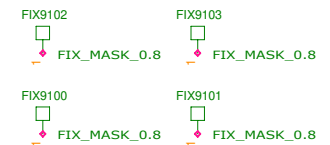
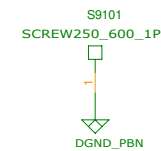
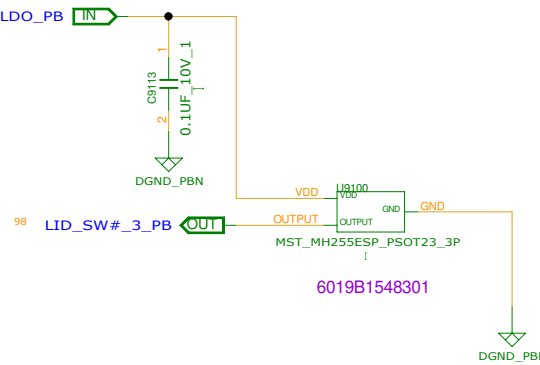
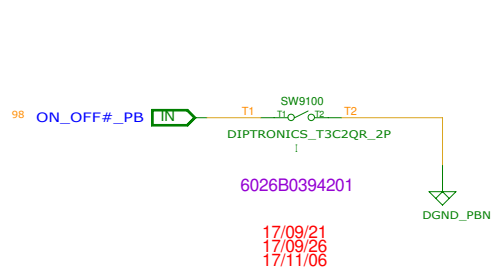
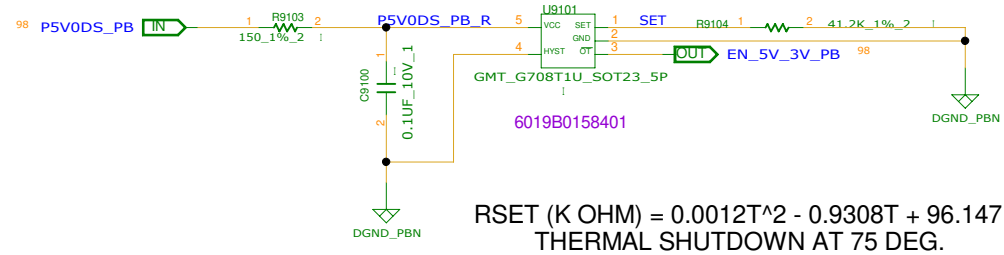

POWER SWITCH DAUGHTER BOARD

LOCATION NUMBER:9000~9099

INVENTEC				
TITLE MODEL PROJECT FUNCTION POWER BUTTON BOARD				
SIZE A3	CODE CS	DOC NUMBER 1310xxxx-0-0	REV X01	
CHANGE by PCB P/N		DATE PCB VER	21-OCT-2002 XXX	
SHEET		57 of 66		

CHANGE by	XXX	DATE	21-OCT-2002
PCB P/N	60xxxxxxxxxxx	PCB VER	XXX

POWER BUTTON BOARD LED

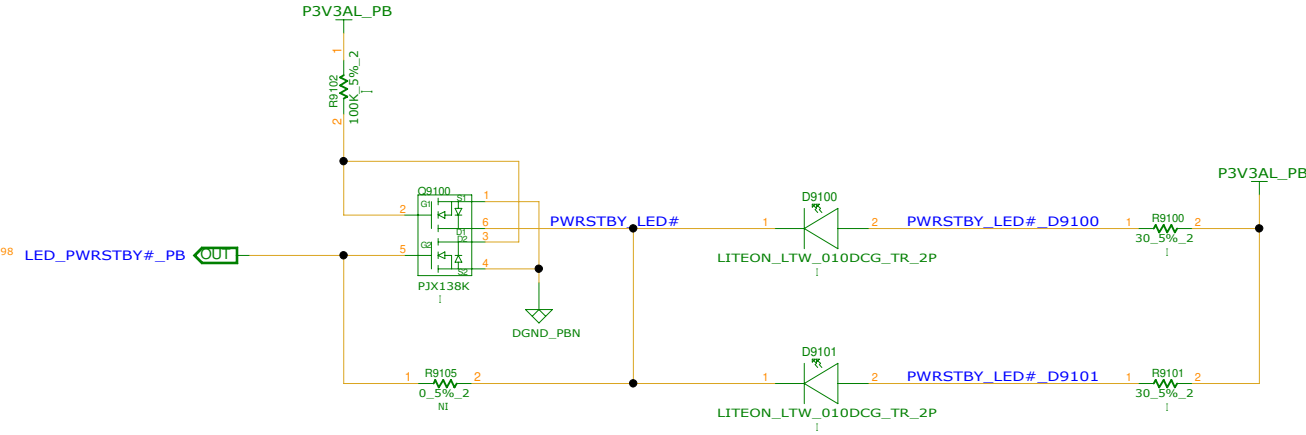

LOCATION NUMBER:9000~9099

INVENTEC

TITLE		MODEL PROJECT FUNCTION		REV
POWER BUTTON BOARD LED		1310xxxx-0-0		X01
SIZE	CODE	DOC NUMBER	REV	
A3	CS	1310xxxx-0-0	X01	
SHEET		58 of 66		

CHANGE by	XXX	DATE	21-OCT-2002
PCB P/N	60xxxxxxxxxxx	PCB VER	XXX

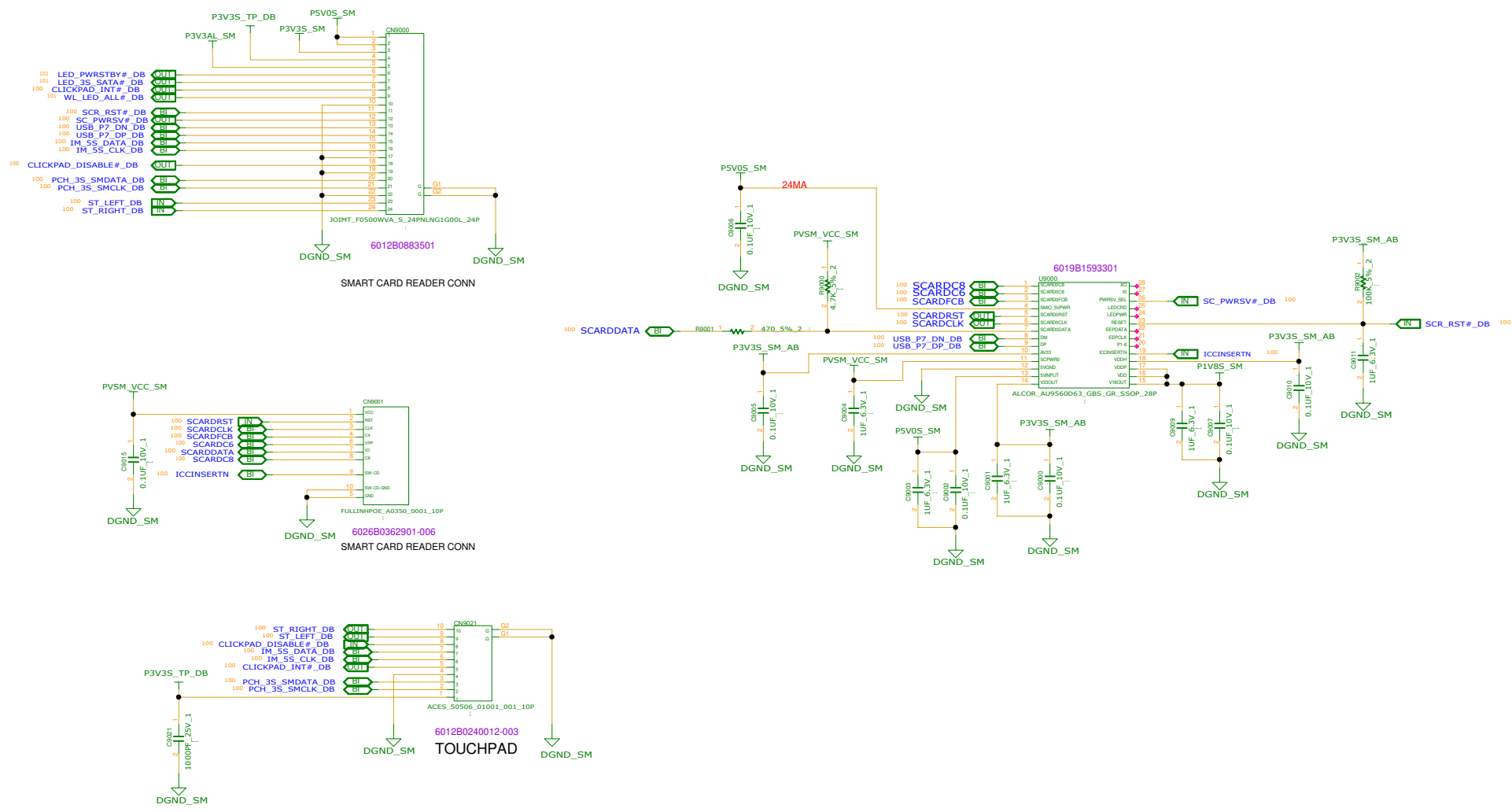

- FIX9000
FIX_MASK_0.8
- FIX9001
FIX_MASK_0.8
- FIX9002
FIX_MASK_0.8
- FIX9003
FIX_MASK_0.8
- FIX9004
FIX_MASK_0.8
- FIX9005
FIX_MASK_0.8

LOCATION NUMBER:9100~9199

INVENTEC			
TITLE MODEL_PROJECT_FUNCTION SMART_CARD_DB			
CHANGE#	XXX	DATE	21-OCT-2002
PCB PIN	60XXXXXXX	PCB VER	XXX
SIZE A1	CS	DOC NUMBER	1310XXXX-2-0
SHEET	01	REV	01

SMART CARD D/B LED

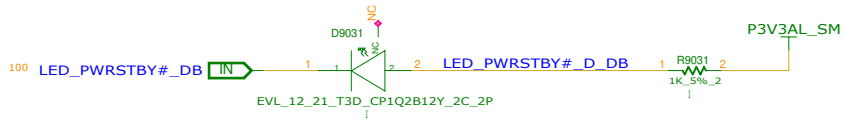

6011B0115101-005
POWER LED

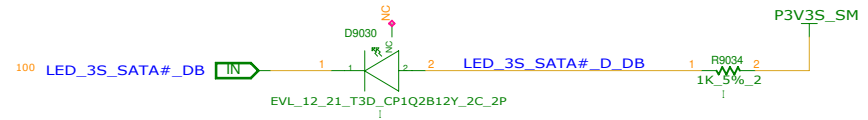

6011B0115101-005
SATA LED

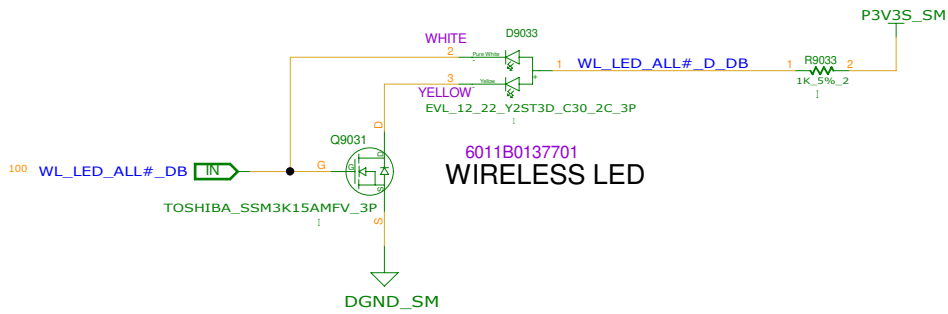

6011B0137701
WIRELESS LED

LOCATION NUMBER:9100~9199

INVENTEC			
TITLE MODEL,PROJECT,FUNCTION SMART CARD D/B LED			
SIZE A3	CODE CS	DOC.NUMBER 1310xxxxx-0-0	REV X01
CHANGE by PCB P/N		DATE PCB VER	SHEET
XXX 60xxxxxxxxxxx		21-OCT-2002 XXX	60 of 66

CHANGE by	XXX	DATE	21-OCT-2002
PCB P/N	60xxxxxxxxxxx	PCB VER	XXX

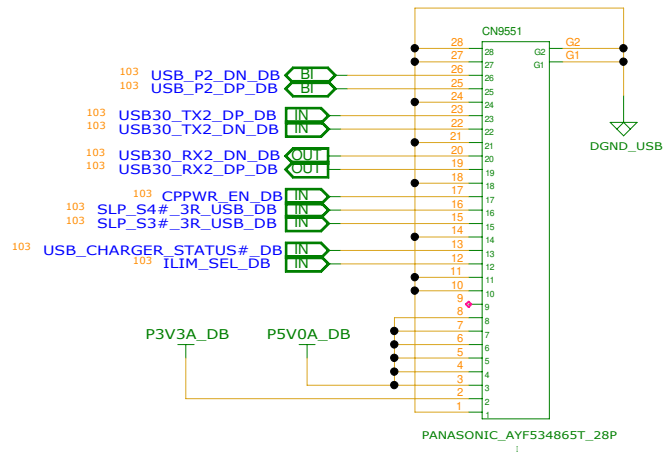

6012B0440205-001

NOTE : CN9551.13 IS PLT_ID3, NOT GND

USB DB CNTR

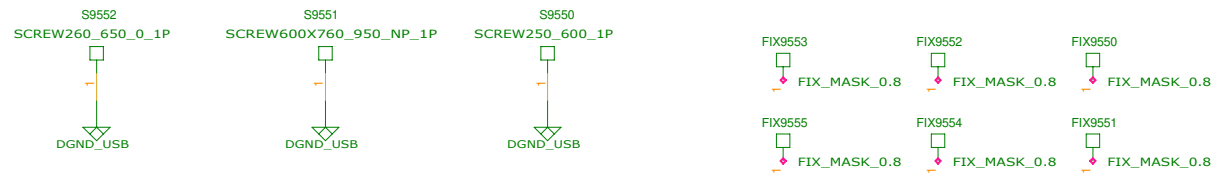

LOCATION NUMBER:9200~9299

INVENTEC			
TITLE MODEL,PROJECT,FUNCTION USB_DB_CNTR			
SIZE A3	CODE CS	DOC NUMBER 1310xxxx-0-0	REV X01
CHANGE by PCB P/N		DATE PCB VER	SHEET
XXX 60xxxxxxxxxx		21-OCT-2002 XXX	61 of 66

CHANGE by	XXX	DATE	21-OCT-2002
PCB P/N	60xxxxxxxxxx	PCB VER	XXX

USB_TYPEA_CHARGING PORT

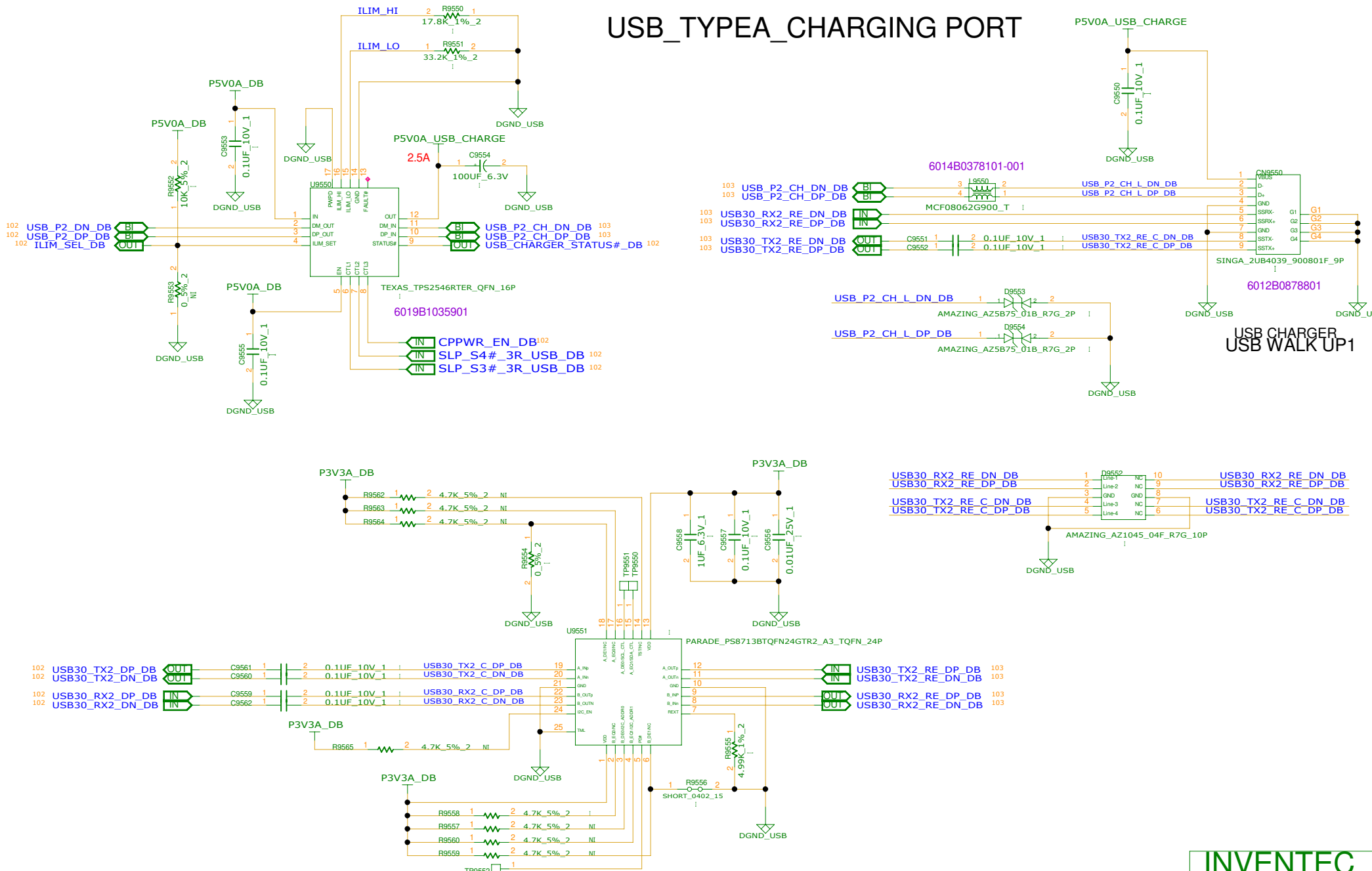

LOCATION NUMBER:9200~9299

INVENTEC			
TITLE MODEL PROJECT FUNCTION USB CHARGER PORT			
SIZE A3	CODE CS	DOC NUMBER 1310xxxx-0-0	REV X01
CHANGE by PCB P/N		DATE PCB VER	21-OCT-2002 XXX
SHEET		62 of 66	

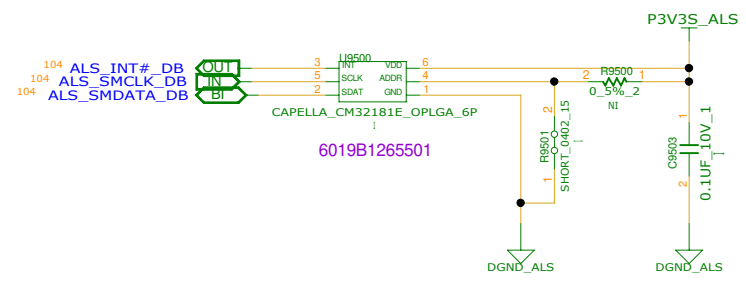
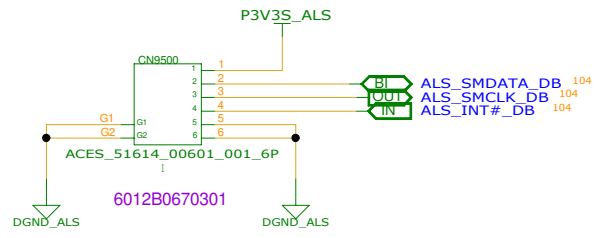

AMBIENT LIGHT SENSOR

ADDR IS HIGH, SELECT ADDRESS 0X48
 ADDR IS LOW, SELECT ADDRESS 0X10



LOCATION NUMBER:9300~9349

INVENTEC			
TITLE MODEL,PROJECT,FUNCTION ALS_D/B			
SIZE A3	CODE CS	DOC.NUMBER 1310xxxx-0-0	REV X01
SHEET 63 of 66			

CHANGE by	XXX	DATE	21-OCT-2002
PCB P/N	60xxxxxxxxxx	PCB VER	XXX

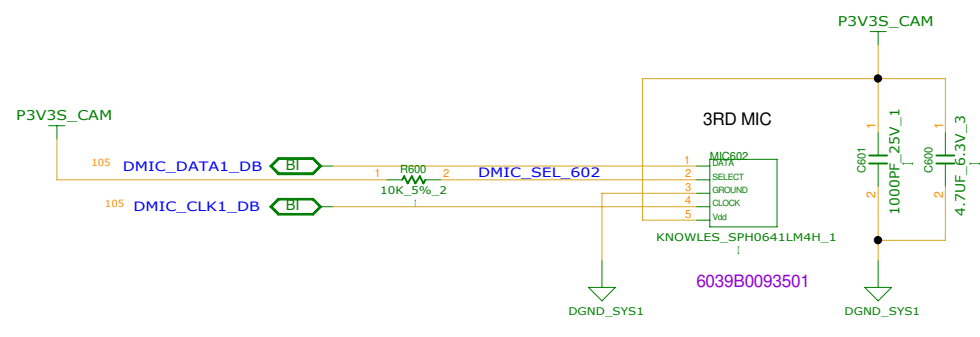
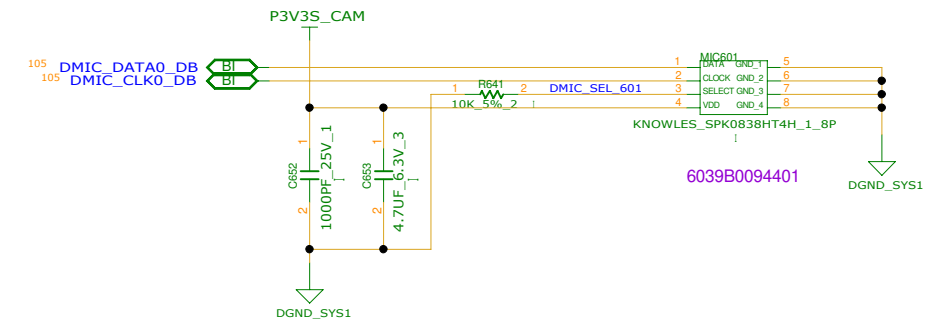
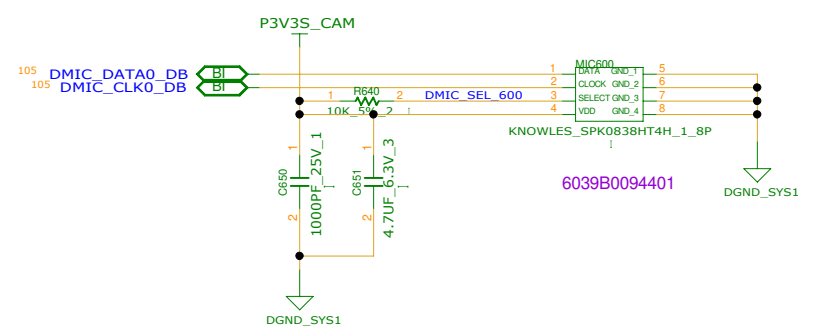

MIC DOUGHTER BOARD

LOCATION NUMBER:9350~9399

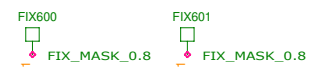

INVENTEC			
TITLE MODEL,PROJECT,FUNCTION MIC_BOARD			
SIZE A3	CODE CS	DOC.NUMBER 1310xxxx-0-0	REV X01
CHANGE by PCB P/N		DATE PCB VER	21-OCT-2002 XXX
SHEET		64 of 66	

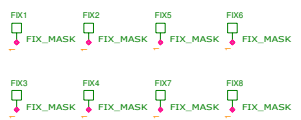
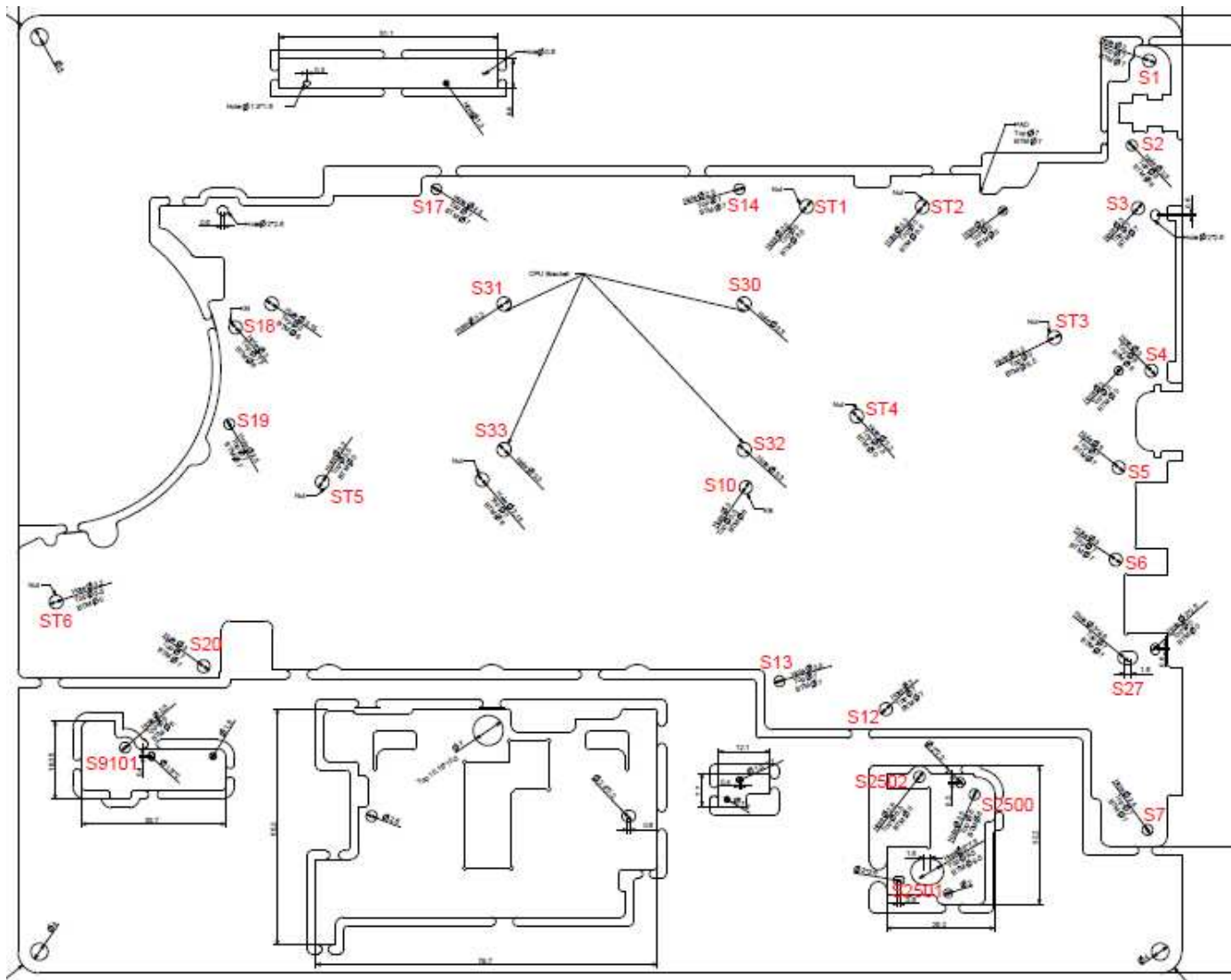
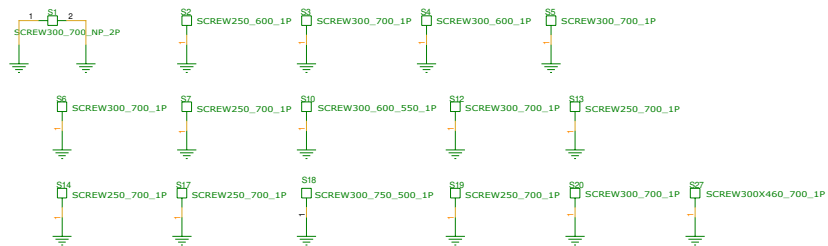
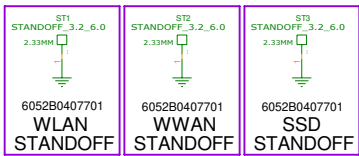
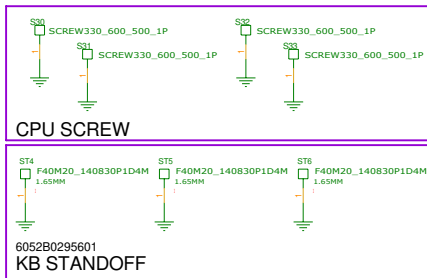

CHANGE#		xxx	DATE	21-OCT-2002	SIZE	CODE	DOCNUMBER	REV
PCBPN		60xxxxxxxxxx	PCBVER	xxx	A5	CS	1310xxxxx-2-0	X01
SHEET		65			of 65			

TITLE		
MODEL_PROJECT_FUNCTION		
Block Diagram		

