

## BLOCK DIAGRAM

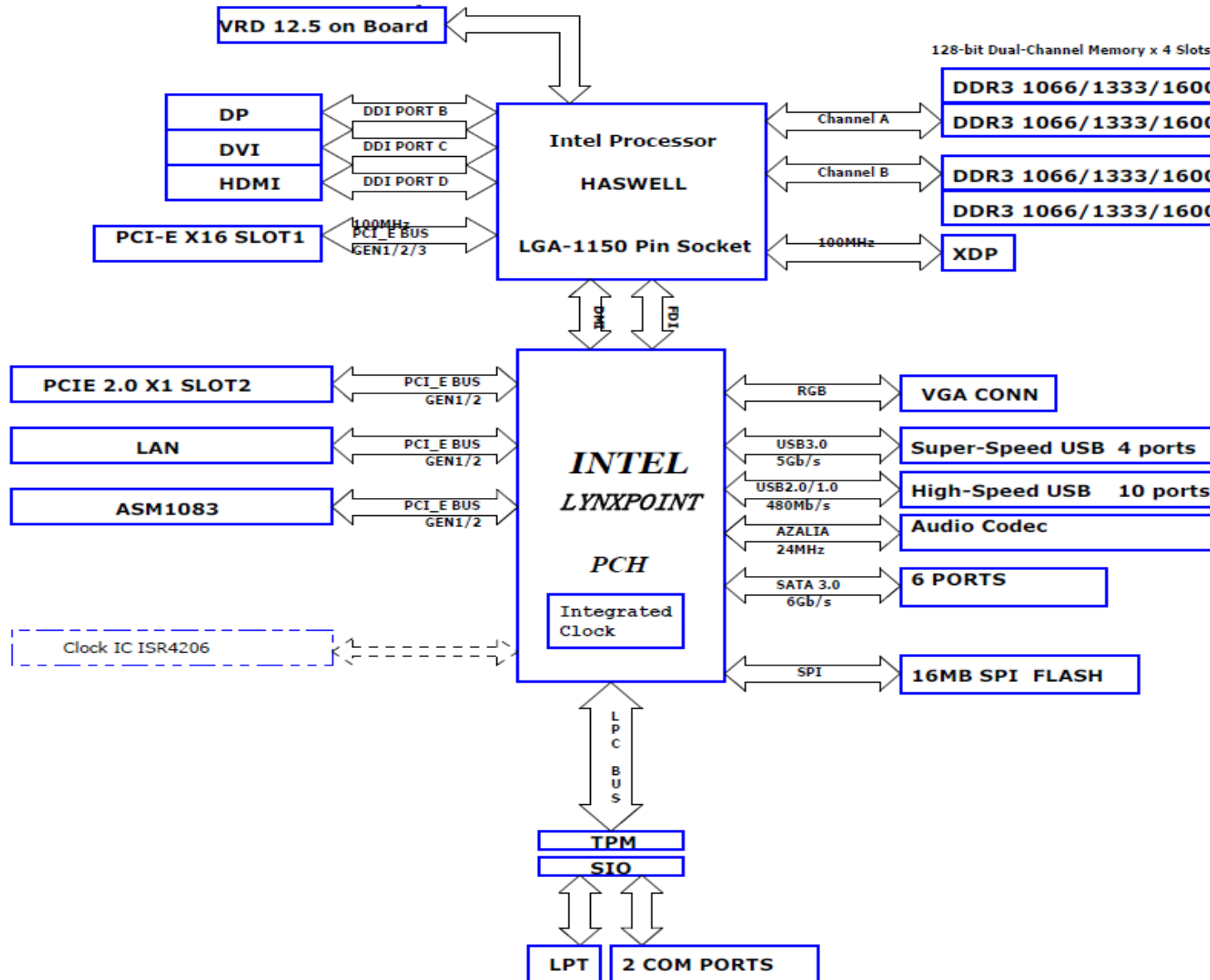

# POWER FLOW

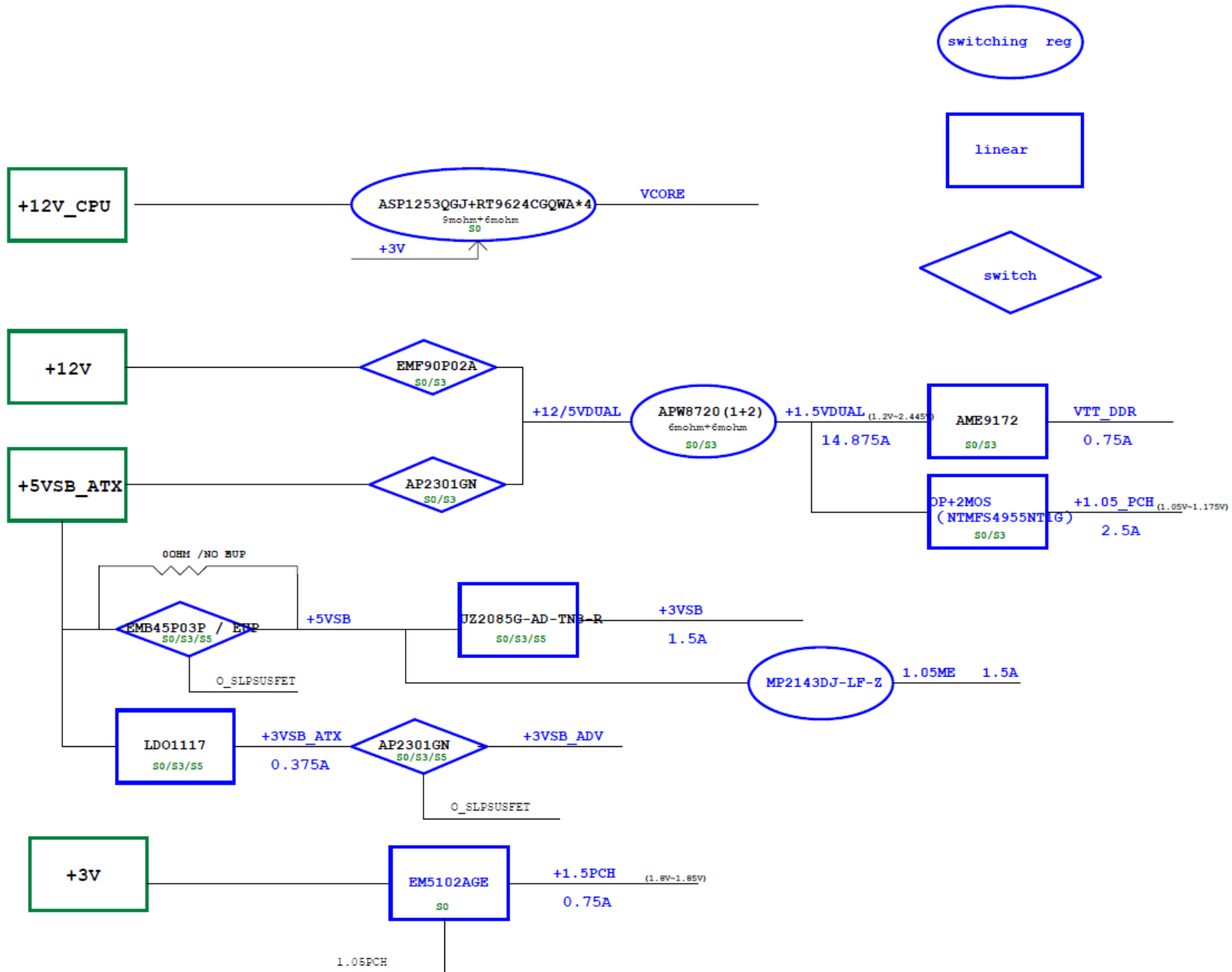

# POWER ON SEQUENCE

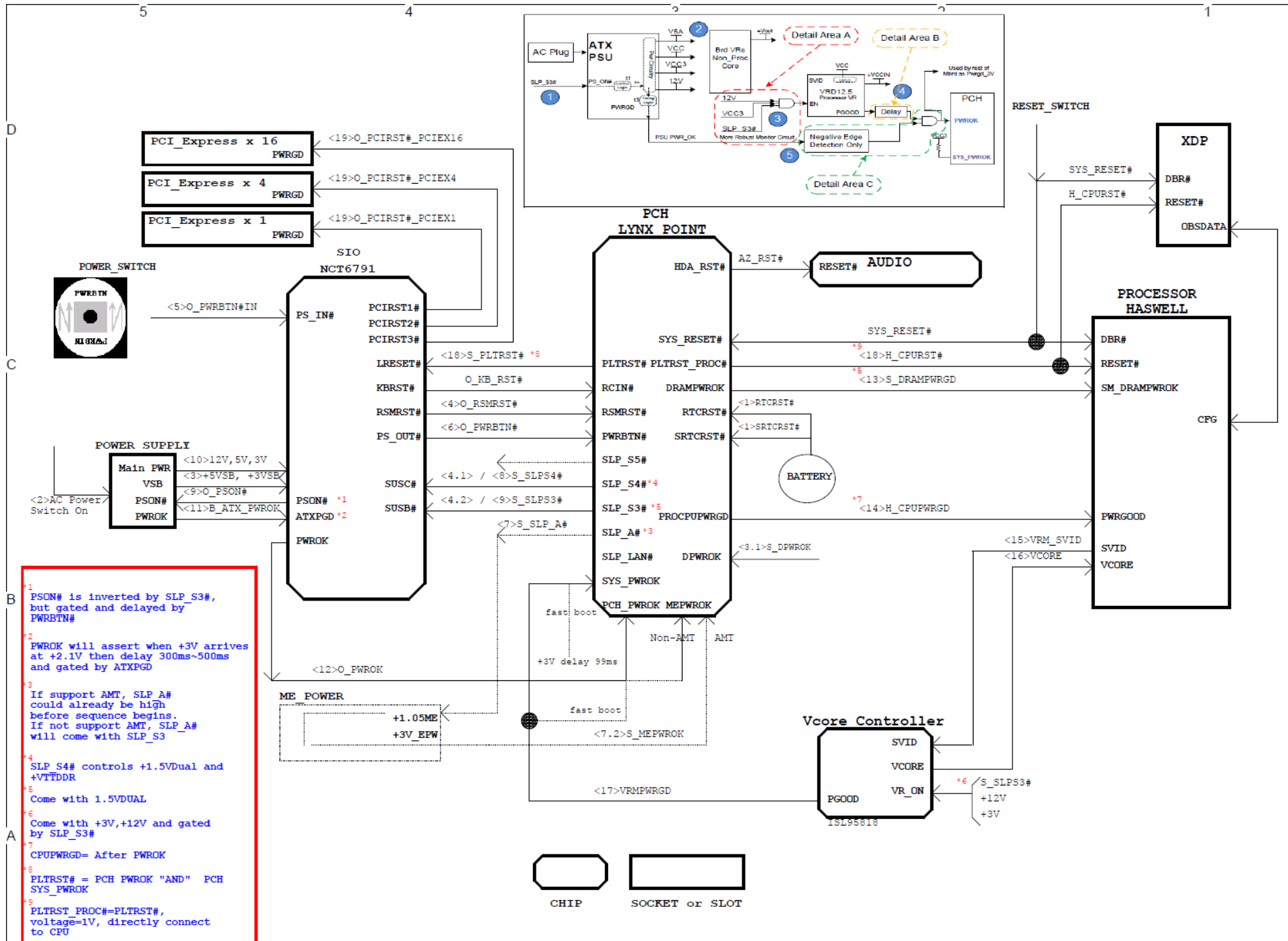

# Frequency Flow

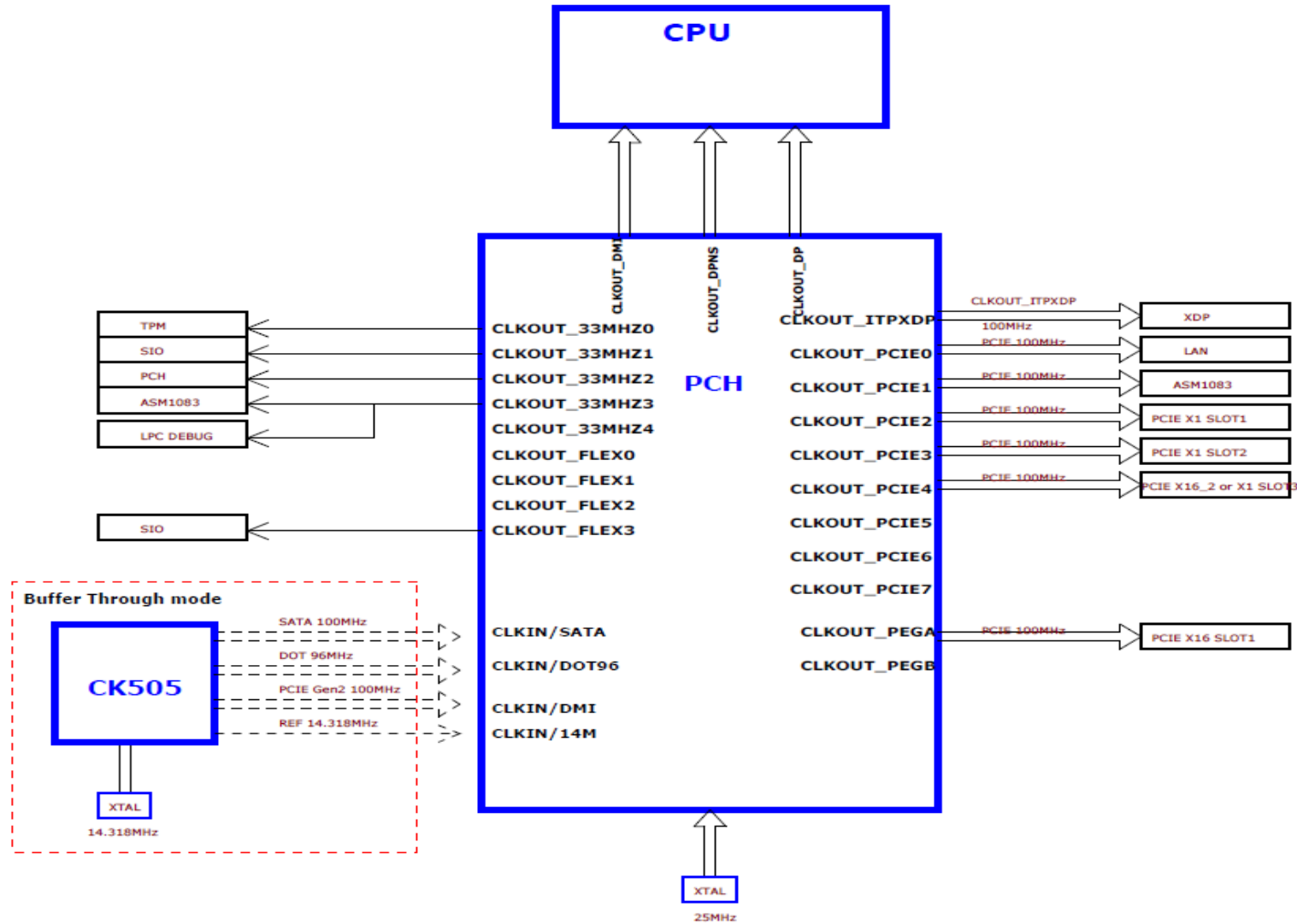

# Voltage Measure Point

multi meter "V  $\Omega$  mA" port touch here

Pink number is Diode resistance to GND(without any part on MB)multimeter type DH-1240

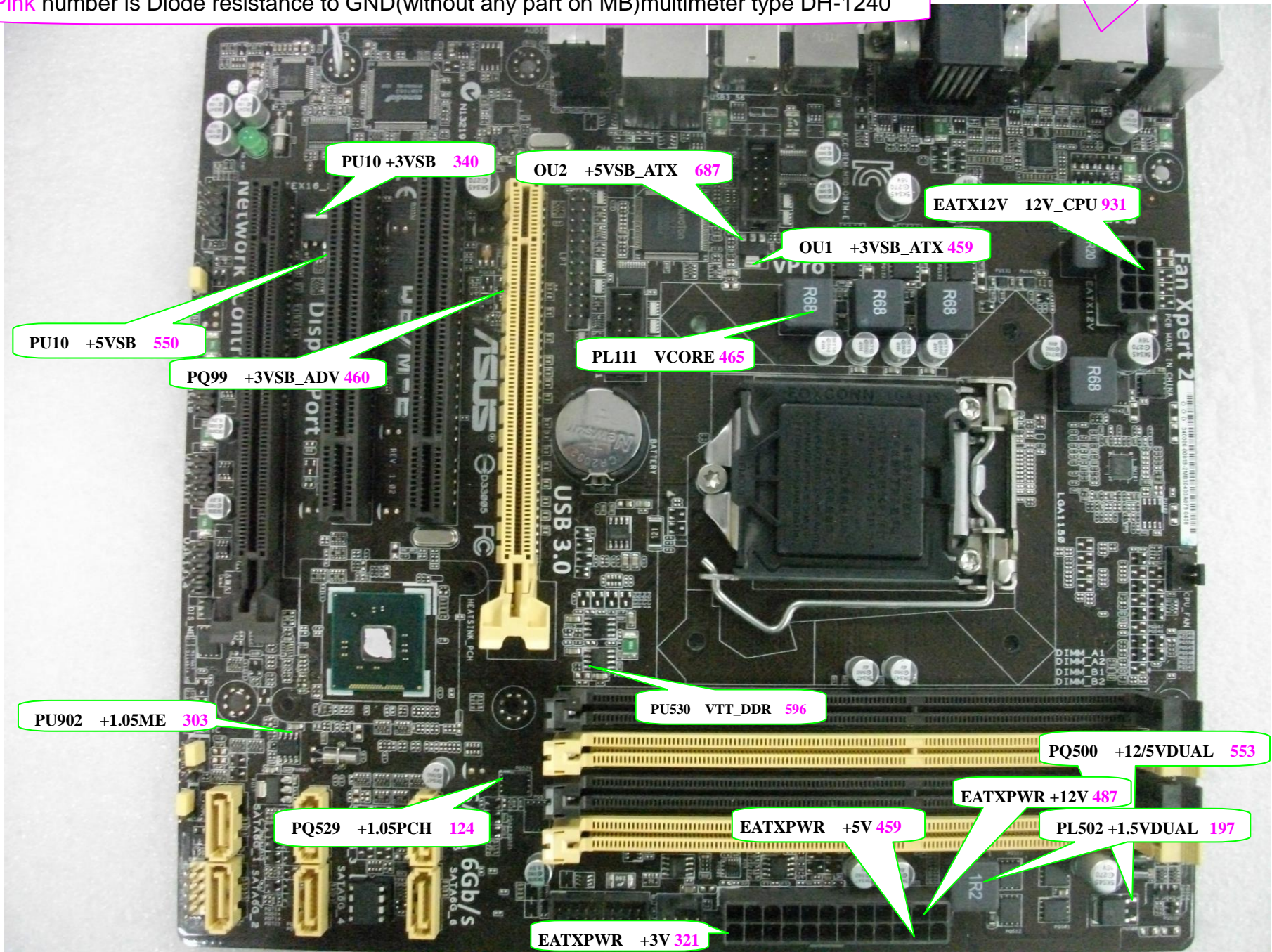

# Signal Measure Point

