

SERVICE MANUAL

NH50RA / NH50RH / NH57RA / NH57RH

notebook



Notebook Computer

NH50RA / NH50RH / NH57RA / NH57RH

Service Manual

Notice

The company reserves the right to revise this publication or to change its contents without notice. Information contained herein is for reference only and does not constitute a commitment on the part of the manufacturer or any subsequent vendor. They assume no responsibility or liability for any errors or inaccuracies that may appear in this publication nor are they in anyway responsible for any loss or damage resulting from the use (or misuse) of this publication.

This publication and any accompanying software may not, in whole or in part, be reproduced, translated, transmitted or reduced to any machine readable form without prior consent from the vendor, manufacturer or creators of this publication, except for copies kept by the user for backup purposes.

Brand and product names mentioned in this publication may or may not be copyrights and/or registered trademarks of their respective companies. They are mentioned for identification purposes only and are not intended as an endorsement of that product or its manufacturer.

Version 1.0
May 2019

Trademarks

Intel and Intel Core are trademarks of Intel Corporation.

Windows[®] is a registered trademark of Microsoft Corporation.

Other brand and product names are trademarks and /or registered trademarks of their respective companies.



About this Manual

This manual is intended for service personnel who have completed sufficient training to undertake the maintenance and inspection of personal computers.

It is organized to allow you to look up basic information for servicing and/or upgrading components of the *NH50RA* / *NH50RH* / *NH57RA* / *NH57RH* series notebook PC.

The following information is included:

Chapter 1, Introduction, provides general information about the location of system elements and their specifications.

Chapter 2, Disassembly, provides step-by-step instructions for disassembling parts and subsystems and how to upgrade elements of the system.

Appendix A, Part Lists

Appendix B, Schematic Diagrams

IMPORTANT SAFETY INSTRUCTIONS

Follow basic safety precautions, including those listed below, to reduce the risk of fire, electric shock and injury to persons when using any electrical equipment:

1. Do not use this product near water, for example near a bath tub, wash bowl, kitchen sink or laundry tub, in a wet basement or near a swimming pool.
2. Avoid using a telephone (other than a cordless type) during an electrical storm. There may be a remote risk of electrical shock from lightning.
3. Do not use the telephone to report a gas leak in the vicinity of the leak.
4. Use only the power cord and batteries indicated in this manual. Do not dispose of batteries in a fire. They may explode. Check with local codes for possible special disposal instructions.
5. This product is intended to be supplied by a Listed Power Unit as follows:
 - AC Input of 100 - 240V, 50 - 60Hz, DC Output of 19.5V, 6.15A (**120 Watts**) minimum AC/DC Adapter.

FCC Statement

This device complies with Part 15 of the FCC Rules. Operation is subject to the following two conditions:

This device may not cause harmful interference.

This device must accept any interference received, including interference that may cause undesired operation.

Instructions for Care and Operation

The notebook computer is quite rugged, but it can be damaged. To prevent this, follow these suggestions:

1. **Don't drop it, or expose it to shock.** If the computer falls, the case and the components could be damaged.

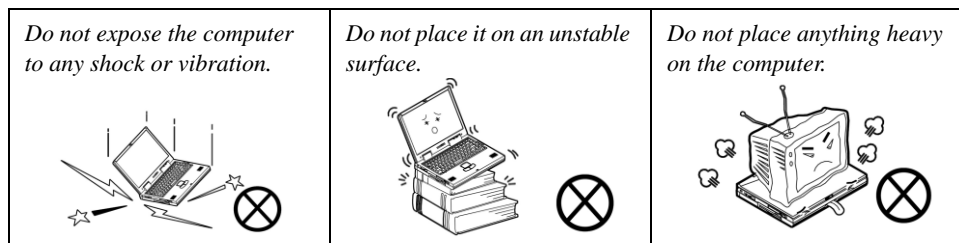

2. **Keep it dry, and don't overheat it.** Keep the computer and power supply away from any kind of heating element. This is an electrical appliance. If water or any other liquid gets into it, the computer could be badly damaged.

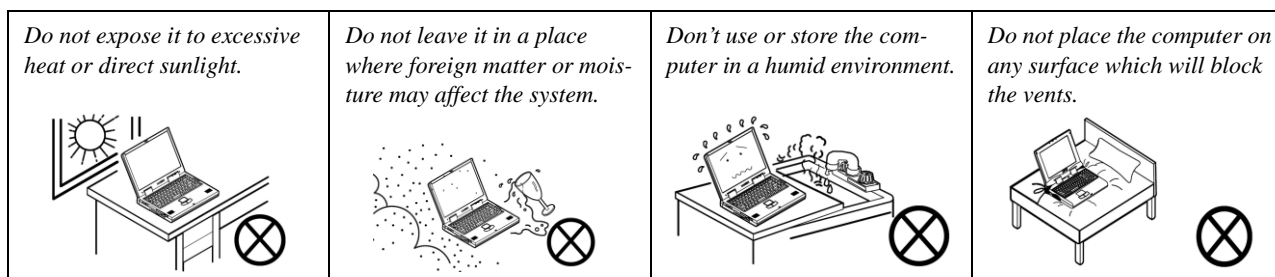

3. **Follow the proper working procedures for the computer.** Shut the computer down properly and don't forget to save your work. Remember to periodically save your data as data may be lost if the battery is depleted.

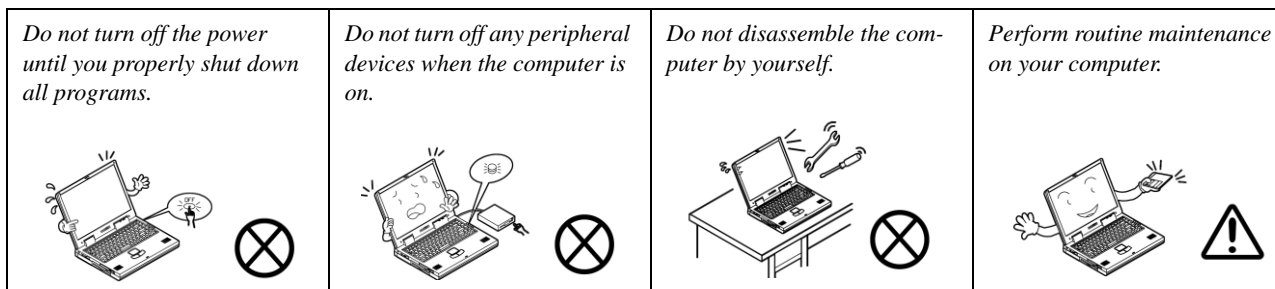

4. **Avoid interference.** Keep the computer away from high capacity transformers, electric motors, and other strong magnetic fields. These can hinder proper performance and damage your data.
5. **Take care when using peripheral devices.**

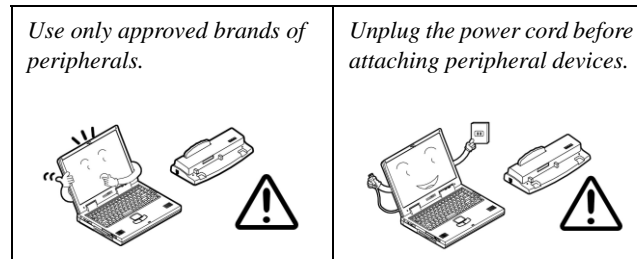

Power Safety

The computer has specific power requirements:

- Only use a power adapter approved for use with this computer.
- Your AC adapter may be designed for international travel but it still requires a steady, uninterrupted power supply. If you are unsure of your local power specifications, consult your service representative or local power company.
- The power adapter may have either a 2-prong or a 3-prong grounded plug. The third prong is an important safety feature; do not defeat its purpose. If you do not have access to a compatible outlet, have a qualified electrician install one.
- When you want to unplug the power cord, be sure to disconnect it by the plug head, not by its wire.
- Make sure the socket and any extension cord(s) you use can support the total current load of all the connected devices.
- Before cleaning the computer, make sure it is disconnected from any external power supplies.

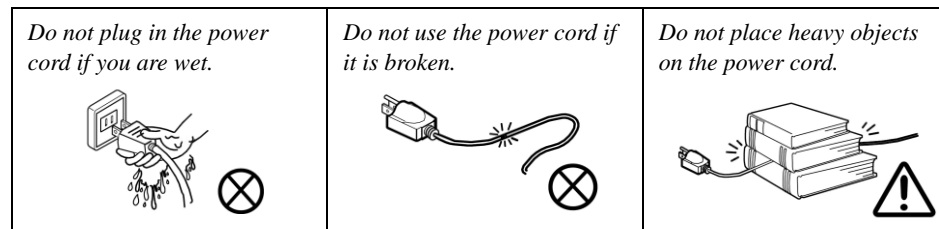

Power Safety Warning

Before you undertake any upgrade procedures, make sure that you have turned off the power, and disconnected all peripherals and cables (including telephone lines and power cord). It is advisable to also remove your battery in order to prevent accidentally turning the machine on.

Battery Precautions

- Only use batteries designed for this computer. The wrong battery type may explode, leak or damage the computer.
- Do not continue to use a battery that has been dropped, or that appears damaged (e.g. bent or twisted) in any way. Even if the computer continues to work with a damaged battery in place, it may cause circuit damage, which may possibly result in fire.
- Recharge the batteries using the notebook's system. Incorrect recharging may make the battery explode.
- Do not try to repair a battery pack. Refer any battery pack repair or replacement to your service representative or qualified service personnel.
- Keep children away from, and promptly dispose of a damaged battery. Always dispose of batteries carefully. Batteries may explode or leak if exposed to fire, or improperly handled or discarded.
- Keep the battery away from metal appliances.
- Affix tape to the battery contacts before disposing of the battery.
- Do not touch the battery contacts with your hands or metal objects.

Battery Guidelines

The following can also apply to any backup batteries you may have.

- If you do not use the battery for an extended period, then remove the battery from the computer for storage.
- Before removing the battery for storage charge it to 60% - 70%.
- Check stored batteries at least every 3 months and charge them to 60% - 70%.



Battery Disposal

The product that you have purchased contains a rechargeable battery. The battery is recyclable. At the end of its useful life, under various state and local laws, it may be illegal to dispose of this battery into the municipal waste stream. Check with your local solid waste officials for details in your area for recycling options or proper disposal.

Caution

Danger of explosion if battery is incorrectly replaced. Replace only with the same or equivalent type recommended by the manufacturer. Discard used battery according to the manufacturer's instructions.

Battery Level

Click the battery icon  in the taskbar to see the current battery level and charge status. A battery that drops below a level of 10% will not allow the computer to boot up. Make sure that any battery that drops below 10% is recharged within one week.

Related Documents

You may also need to consult the following manual for additional information:

User's Manual on CD/DVD

This describes the notebook PC's features and the procedures for operating the computer and its ROM-based setup program. It also describes the installation and operation of the utility programs provided with the notebook PC.

System Startup

1. Remove all packing materials.
2. Place the computer on a stable surface.
3. Insert the battery and make sure it is locked in position.
4. Securely attach any peripherals you want to use with the computer (e.g. keyboard and mouse) to their ports.
5. **When first setting up the computer use the following procedure** (as to safeguard the computer during shipping, the battery will be locked to not power the system until first connected to the AC/DC adapter and initially set up as below):
 - Attach the AC/DC adapter cord to the DC-In jack on the rear of the computer, then plug the AC power cord into an outlet, and connect the AC power cord to the AC/DC adapter and **leave it there for 6 seconds or longer**.
 - Remove the adapter cord from the computer's DC-In jack, and then plug it back in again; the battery will now be unlocked.
6. Use one hand to raise the lid/LCD to a comfortable viewing angle (do not exceed 130 degrees); use the other hand (as illustrated in Figure 1) to support the base of the computer (**Note: Never** lift the computer by the lid/LCD).
7. Press the power button to turn the computer "on".

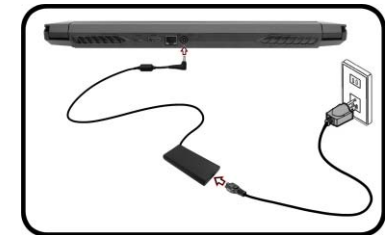
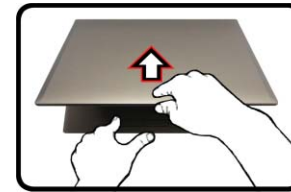



Figure 1
**Opening the Lid/LCD/
Computer with AC/DC
Adapter Plugged-In**



Shut Down

Note that you should always shut your computer down by choosing the **Shut down** command in **Windows** (see below). This will help prevent hard disk or system problems.

Click the icon  in the **Start Screen** and choose **Shut down** from the menu.



Or

Right-click the **Start button**  at the bottom of the **Start Screen** or the **Desktop** and choose **Shut down or sign out** > **Shut down** from the context menu.

Contents

Introduction	1-1	Bottom	A-5
Overview	1-1	Main Board	A-6
Specifications	1-2	HDD	A-7
External Locator - Top View with LCD Panel Open	1-4	LCD (NH50RA / NH50RH)	A-8
External Locator - Front & Right Side Views	1-5	LCD (NH57RA / NH57RH)	A-9
External Locator - Left Side & Rear View	1-6	Schematic Diagrams.....	B-1
External Locator - Bottom View	1-7	System Block Diagram	B-2
Mainboard Overview - Top (Key Parts)	1-8	Processor 1/6	B-3
Mainboard Overview - Bottom (Key Parts)	1-9	Processor 2/6	B-4
Mainboard Overview - Top (Connectors)	1-10	Processor 3/6	B-5
Mainboard Overview - Bottom (Connectors)	1-11	Processor 4/6	B-6
Disassembly	2-1	Processor 5/6	B-7
Overview	2-1	Processor 6/6	B-8
Maintenance Tools	2-2	DDR4 CHA SO-DIMM	B-9
Connections	2-2	DDR4 CHB SO-DIMM	B-10
Maintenance Precautions	2-3	VGA PCI Express	B-11
Disassembly Steps	2-4	VGA Frame Buffer Interface	B-12
Removing the Battery	2-5	Frame Buffer A	B-13
Removing the Keyboard	2-6	Frame Buffer A	B-14
Removing the Hard Disk Drive	2-7	Frame Buffer B	B-15
Removing the System Memory (RAM)	2-9	Frame Buffer B	B-16
Removing the M.2 SSD Module	2-10	VGA I/O	B-17
Removing the Wireless LAN Module	2-11	NVIDIA Power Sequence	B-18
Wireless LAN, Combo Module Cables	2-12	NVIDIA GPIO Level Shift	B-19
Removing the CCD	2-13	VGA PWR / GND	B-20
Part Lists	A-1	VGA NVVDD Coupling	B-21
Part List Illustration Location	A-2	MDP	B-22
Top (NH50RA / NH50RH)	A-3	Panel, Inverter	B-23
Top (NH57RA / NH57RH)	A-4	HDMI	B-24
		PCH 1/9	B-25

Preface

PCH 2/9	B-26	Hall Sensor Board	B-58
PCH 3/9	B-27	Click Board	B-59
PCH 4/9	B-28	LED Board	B-60
PCH 5/9	B-29	NH70 PW Board	B-61
PCH 6/9	B-30	Audio Codec	B-62
PCH 7/9	B-31	Power Measurement	B-63
PCH 8/9	B-32	Power Sequence	B-64
PCH 9/9	B-33	Audio Board	B-65
M.2 Card	B-34		
M.2 WLAN+BT	B-35		
USB Charger	B-36		
Card Reader / LAN RTL8411B	B-37		
HDD, Click TP, Audio, Hall Con.	B-38		
LED, CCD, TPM, Power SW Con.	B-39		
KBC-ITE IT5570	B-40		
RGB KB Only	B-41		
5V, 5VS, 3.3V, 3.3VS	B-42		
VDD1.05V, VCCIO	B-43		
VDD3, VDD5	B-44		
DDR 1.2V / 0.6VS, 2.5V	B-45		
VCore Output Stage	B-46		
VCC_Core & VCCGT	B-47		
1.05DX_VCCSTG/VCCSFR_OC	B-48		
VCCGT & VCCSA Output Stage	B-49		
AC_In, Charger	B-50		
NVVDD1	B-51		
NVVDD2	B-52		
PEX_VDD	B-53		
FBVDDQ	B-54		
1V8_RUN/AON	B-55		
Audio Board	B-56		
NH50 PW Board	B-57		

Chapter 1: Introduction

Overview

This manual covers the information you need to service or upgrade the *NH50RA / NH50RH / NH57RA / NH57RH* series notebook computer. Information about operating the computer (e.g. getting started, and the *Setup* utility) is in the *User's Manual*. Information about drivers (e.g. VGA & audio) is also found in the *User's Manual*. The manual is shipped with the computer.

Operating systems (e.g. *Windows 10*, etc.) have their own manuals as do application softwares (e.g. word processing and database programs). If you have questions about those programs, you should consult those manuals.

The *NH50RA / NH50RH / NH57RA / NH57RH* series notebook is designed to be upgradeable. See [Disassembly on page 2 - 1](#) for a detailed description of the upgrade procedures for each specific component. Please take note of the warning and safety information indicated by the “” symbol.

The balance of this chapter reviews the computer's technical specifications and features.

Introduction

Specifications



Latest Specification Information

The specifications listed here are correct at the time of sending them to the press. Certain items (particularly processor types/speeds) may be changed, delayed or updated due to the manufacturer's release schedule. Check with your service center for more details.



CPU

The CPU is not a user serviceable part. Accessing the CPU in any way may violate your warranty.

Processor Options

Intel® Core™ i7 Processor

i7-9750H (2.60GHz)

12MB Smart Cache, 14nm, DDR4-2666MHz, TDP 45W

Intel® Core™ i5 Processor

i5-9300H (2.40GHz)

8MB Smart Cache, 14nm, DDR4-2666MHz, TDP 45W

Core Logic

Intel® HM370 Express Chipset

BIOS

128Mb SPI Flash ROM

INSYDE BIOS

Memory

Dual Channel DDR4

Two 260 Pin SO-DIMM Sockets

Supporting **DDR4 2666MHz** Memory Modules

Memory Expandable from **8GB (minimum)** up to **64GB (maximum)**

Compatible with 4GB, 8GB, 16GB or 32GB Modules

(The real memory operating frequency depends on the FSB of the processor.)

Storage

One changeable 2.5" (6cm) **7.0mm (h) SATA** (Serial) Hard Disk Drive/Solid State Drive (SSD)

(Factory Option) One M.2 2280 **SATA** Solid State Drive (SSD)

Or

(Factory Option) Two **PCIe Gen3 x4** M.2 2280 SSDs supporting RAID level 0/1

Audio

High Definition Audio Compliant Interface

Sound Blaster™ Cinema 5

Built-In Array Microphone

Two Speakers

LCD Options

15.6" (39.62cm), 16:9, FHD (1920x1080)

Video Adapter

Intel® Integrated GPU and NVIDIA® Discrete GPU

Supports Microsoft Hybrid Graphics

Intel Integrated GPU

Intel® UHD Graphics 630

Dynamic Frequency

Intel Dynamic Video Memory Technology

Microsoft DirectX®12 Compatible

NVIDIA® Discrete GPU

NVIDIA® GeForce GTX 1650 (for NH50RA/NH57RA)

4GB GDDR6 Video RAM on board

Microsoft DirectX® 12 Compatible

NVIDIA® GeForce GTX 1050 (for NH50RH/NH57RH)

3GB GDDR6 Video RAM on board

Microsoft DirectX® 12 Compatible

Security

Security (Kensington® Type) Lock Slot

BIOS Password

Intel® PTT for Systems Without TPM Hardware

(Factory Option) TPM 2.0

Keyboard

Full-size **Multi-Color** LED Keyboard (with Numeric Keypad)

Pointing Device

Built-in Touchpad (with Microsoft PTP Multi Gesture & Scrolling Functionality)

Interface

One USB 3.1 Gen 2 Type-C Port*

**The maximum amount of current supplied by USB Type-C ports is 500mA (USB 2.0)/1500mA (USB 3.1).*

One USB 3.1 Gen 2 Type-A Port

One USB 3.0 (USB 3.1 Gen 1) Type-A Port

One USB 2.0 Port

One Mini DisplayPort

One HDMI-Out Port

One Microphone-In Jack

One 2-In-1 Audio Jack (Headphone and Microphone)

One RJ-45 LAN Jack

One DC-In Jack

**USB 3.1 Gen 2**

Note that when a single USB device is plugged in to a USB 3.1 Gen 2 port the data transfer speed will be 10Gbps, however when two devices are plugged in to both USB 3.1 Gen 2 ports, this bandwidth will be shared between the ports.

Card Reader

Embedded Multi-In-1 Card Reader

MMC (MultiMedia Card) / RS MMC

SD (Secure Digital) / Mini SD / SDHC/ SDXC

M.2 Slots

Slot 1 for **Combo WLAN and Bluetooth** Module

Slot 2 for **SATA or PCIe Gen3 x4 SSD**

Slot 3 for **PCIe Gen3 x4 SSD**

Communication

Built-In 10/100/1000Mb Base-TX Ethernet LAN

1.0M HD PC Camera Module

WLAN/ Bluetooth M.2 Modules:

(Factory Option) Intel® Dual Band Wireless-AC 9260 Wireless LAN (**802.11ac**) + Bluetooth

(Factory Option) Intel® Dual Band Wireless-AC 9560 Wireless LAN (**802.11ac**) + Bluetooth

(Factory Option) Intel® Dual Band Wireless-AC 9462 Wireless LAN (**802.11ac**) + Bluetooth

(Factory Option) Qualcomm® Atheros Killer™ Wireless-AC 1550i Wireless LAN (**802.11ac**) + Bluetooth

Environmental Spec**Temperature**

Operating: 5°C - 35°C

Non-Operating: -20°C - 60°C

Relative Humidity

Operating: 20% - 80%

Non-Operating: 10% - 90%

Power

Removable 4 Cell Smart Lithium-Ion Battery Pack, 48.96WH

Full Range AC/DC Adapter

AC Input: 100 - 240V, 50 - 60Hz

DC Output: 19.5V, 6.15A (**120W**)

Dimensions & Weight

361mm (w) * 258mm (d) * 24.9mm (h)

2.2kg (Barebone with 48.96WH Battery)

Introduction

Figure 1
Top View

1. PC Camera
2. *PC Camera LED
**When the PC camera is in use, the LED will be illuminated.*
3. Built-In Array Microphone
4. LCD
5. Power Button
6. Keyboard
7. Touchpad & Buttons

External Locator - Top View with LCD Panel Open



External Locator - Front & Right Side Views

FRONT VIEW



Figure 2
Front View
1. LED Indicator

RIGHT SIDE VIEW



Figure 3
Right Side View
1. USB 3.1 Gen 2
Type-A Port
2. USB 3.1 Gen 2
Type-C Port
3. Multi-in-1 Card
Reader
4. Vent

Introduction

External Locator - Left Side & Rear View

Figure 4

Left Side View

1. Security Lock Slot
2. Vent
3. USB 3.0 (USB 3.1 Gen 1) Type-A Port
4. USB 2.0 Port
5. Microphone-In Jack
6. 2-In-1 Audio Jack (Headphone and Microphone)

LEFT SIDE VIEW



REAR VIEW



Figure 5

Rear View

1. Vent
2. Mini DisplayPort
3. HDMI-Out Port
4. RJ-45 LAN Jack
5. DC-In Jack

External Locator - Bottom View

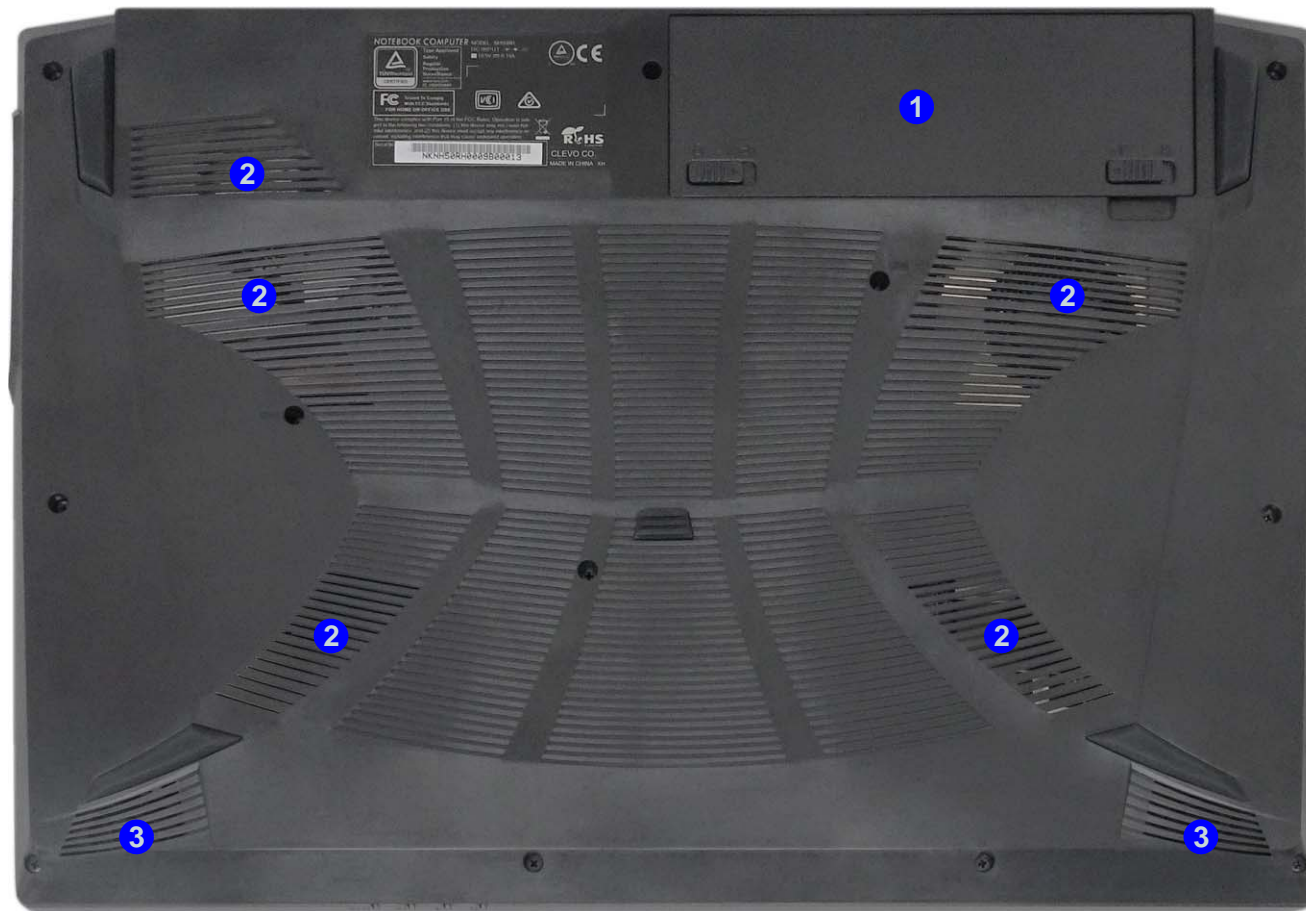

Figure 6
Bottom View

1. Battery
2. Vent
3. Speakers

Overheating

To prevent your computer from overheating, make sure nothing blocks any vent while the computer is in use.

Introduction

Figure 7
Mainboard Top
Key Parts

1. KBC-ITE IT5570

Mainboard Overview - Top (Key Parts)

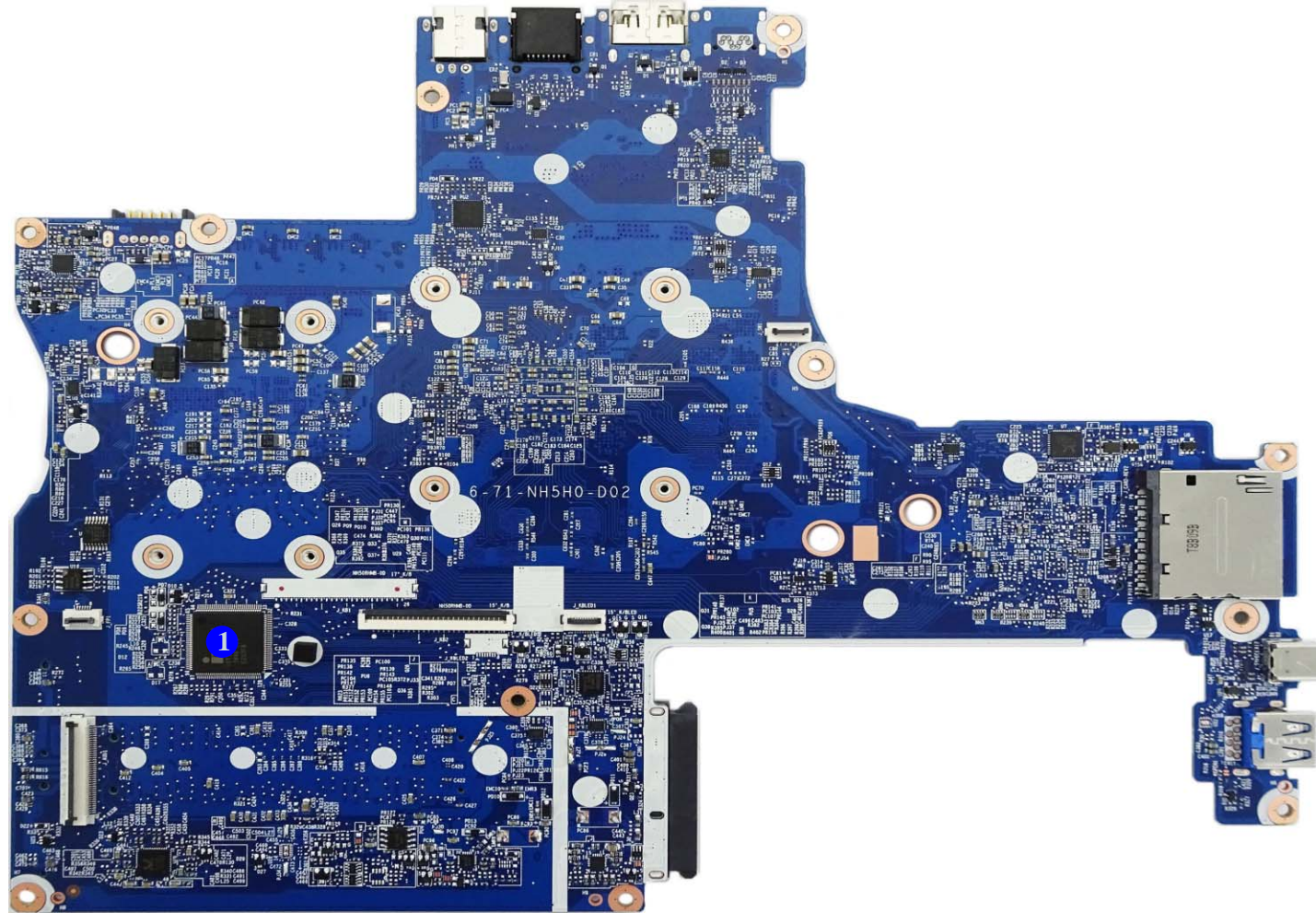

Mainboard Overview - Bottom (Key Parts)

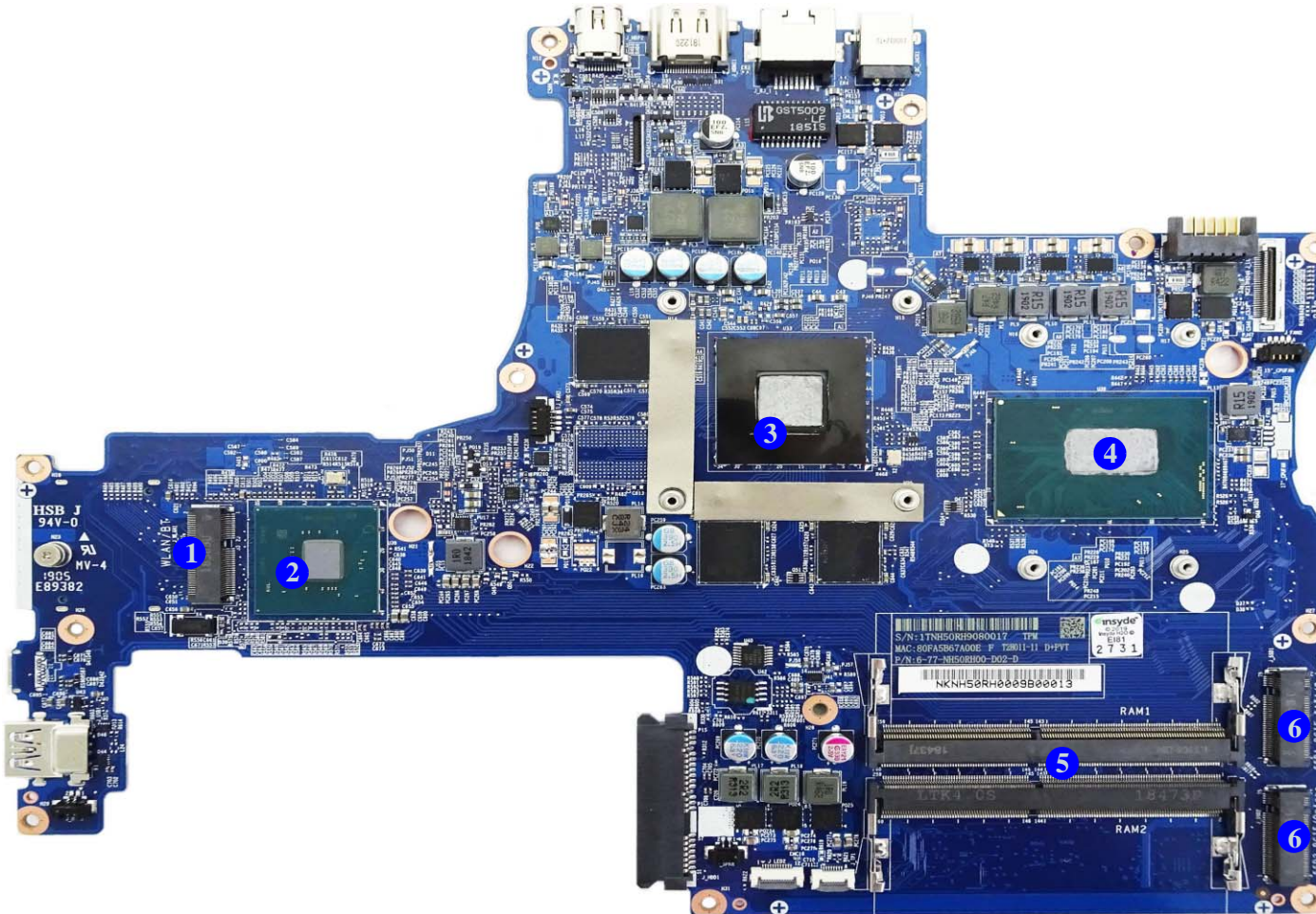

Figure 8
Mainboard Bottom
Key Parts

1. Mini-Card Connector (WLAN Module)
2. PCH
3. GPU
4. CPU
5. Memory Slots (DDR4 SO-DIMM)
6. M.2-Card Connector (SSD Module)

Introduction

Figure 9
**Mainboard Top
Connectors**

1. USB Connector
2. Keyboard Cable Connector
3. KB LED Connector
4. Multi-in-1 Card Reader
5. USB 3.1 Gen 2 Type-C Port
6. USB 3.1 Gen 2 Type-A Port

Mainboard Overview - Top (Connectors)

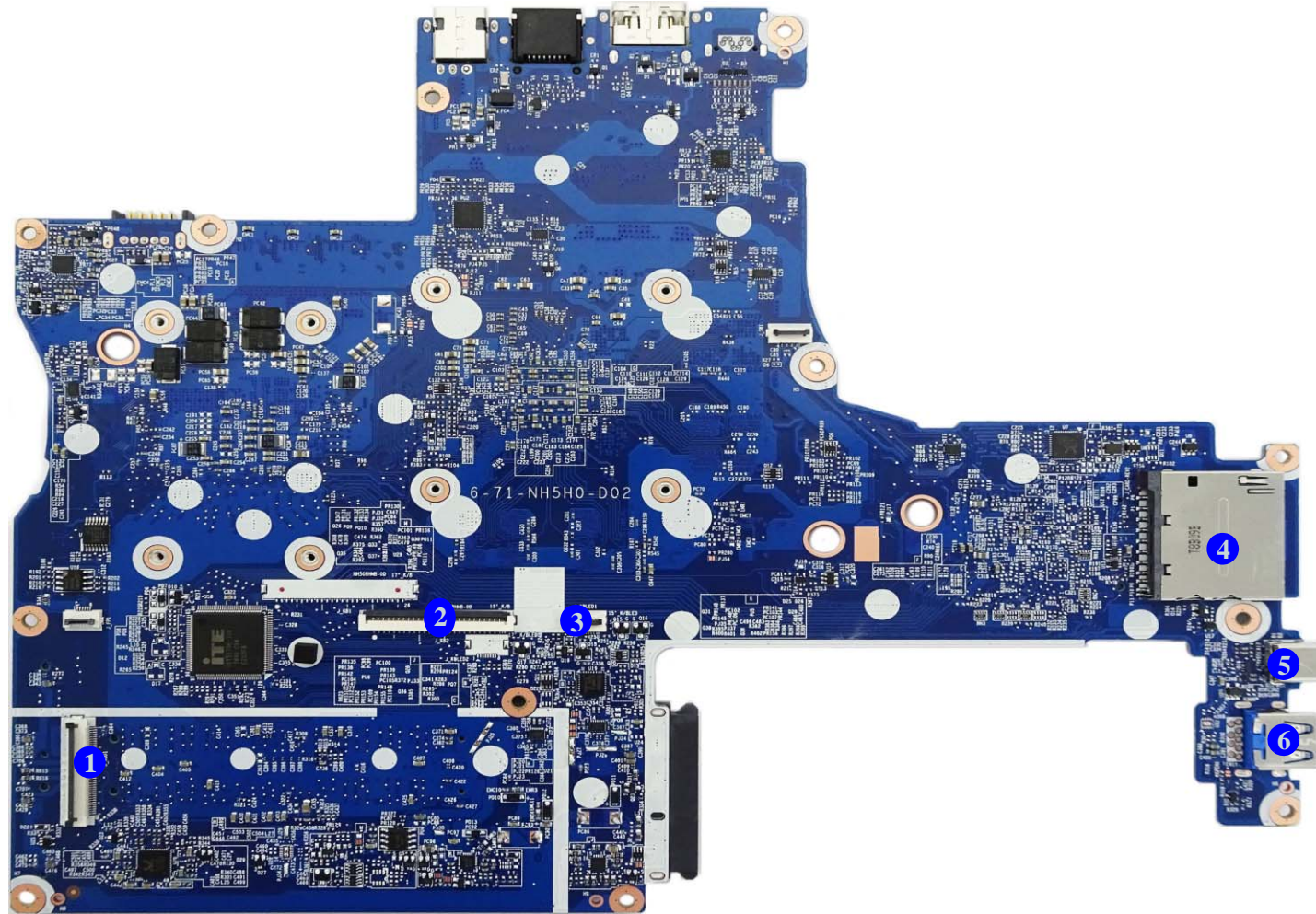

Mainboard Overview - Bottom (Connectors)

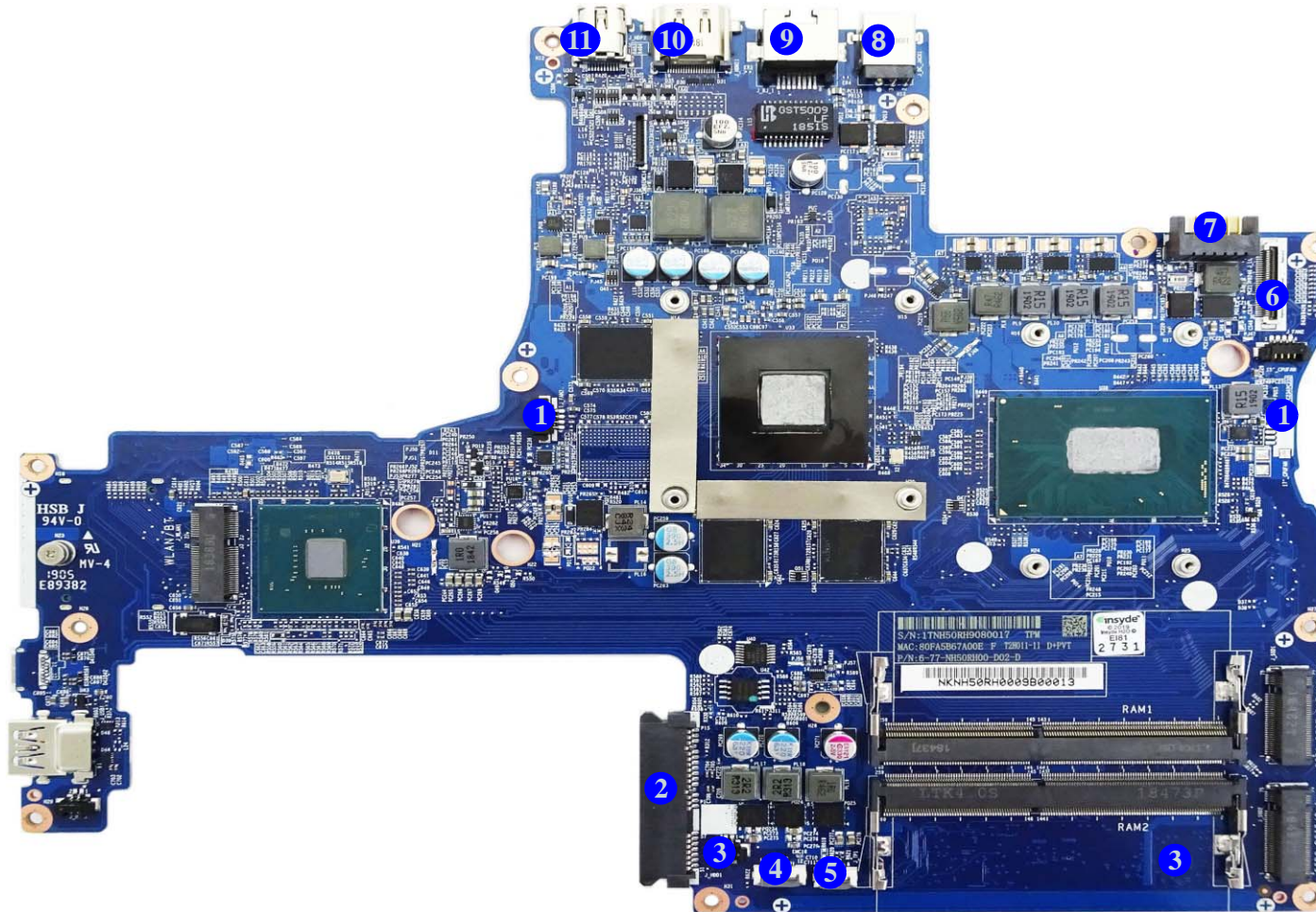

Figure 10
**Mainboard Bottom
Connectors**

1. Fan Connector
2. HDD Connector
3. Speaker Connector
4. LED Connector
5. Touchpad Connector
6. LCD Connector
7. Battery Connector
8. DC-In Jack
9. RJ-45 LAN Jack
10. HDMI-Out Port
11. Mini Display Port

Chapter 2: Disassembly

Overview

This chapter provides step-by-step instructions for disassembling the *NH50RA / NH50RH / NH57RA / NH57RH* series notebook's parts and subsystems. When it comes to reassembly, reverse the procedures (unless otherwise indicated).

We suggest you completely review any procedure before you take the computer apart.

Procedures such as upgrading/replacing the RAM, optical device and hard disk are included in the User's Manual but are repeated here for your convenience.

To make the disassembly process easier each section may have a box in the page margin. Information contained under the figure # will give a synopsis of the sequence of procedures involved in the disassembly procedure. A box with a  lists the relevant parts you will have after the disassembly process is complete. **Note:** The parts listed will be for the disassembly procedure listed ONLY, and not any previous disassembly step(s) required. Refer to the part list for the previous disassembly procedure. The amount of screws you should be left with will be listed here also.

A box with a  will also provide any possible helpful information. A box with a  contains warnings.

An example of these types of boxes are shown in the sidebar.

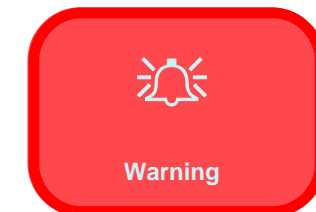
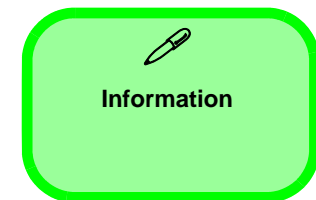

Disassembly

NOTE: All disassembly procedures assume that the system is turned **OFF**, and disconnected from any power supply (the battery is removed too).

Maintenance Tools

The following tools are recommended when working on the notebook PC:

- M3 Philips-head screwdriver
- M2.5 Philips-head screwdriver (magnetized)
- M2 Philips-head screwdriver
- Small flat-head screwdriver
- Pair of needle-nose pliers
- Anti-static wrist-strap



Connections

Connections within the computer are one of four types:

Locking collar sockets for ribbon connectors

To release these connectors, use a small flat-head screwdriver to gently pry the locking collar away from its base. When replacing the connection, make sure the connector is oriented in the same way. The pin1 side is usually not indicated.

Pressure sockets for multi-wire connectors

To release this connector type, grasp it at its head and gently rock it from side to side as you pull it out. Do not pull on the wires themselves. When replacing the connection, do not try to force it. The socket only fits one way.

Pressure sockets for ribbon connectors

To release these connectors, use a small pair of needle-nose pliers to gently lift the connector away from its socket. When replacing the connection, make sure the connector is oriented in the same way. The pin1 side is usually not indicated.

Board-to-board or multi-pin sockets

To separate the boards, gently rock them from side to side as you pull them apart. If the connection is very tight, use a small flat-head screwdriver - use just enough force to start.

Maintenance Precautions

The following precautions are a reminder. To avoid personal injury or damage to the computer while performing a removal and/or replacement job, take the following precautions:

1. **Don't drop it.** Perform your repairs and/or upgrades on a stable surface. If the computer falls, the case and other components could be damaged.
2. **Don't overheat it.** Note the proximity of any heating elements. Keep the computer out of direct sunlight.
3. **Avoid interference.** Note the proximity of any high capacity transformers, electric motors, and other strong magnetic fields. These can hinder proper performance and damage components and/or data. You should also monitor the position of magnetized tools (i.e. screwdrivers).
4. **Keep it dry.** This is an electrical appliance. If water or any other liquid gets into it, the computer could be badly damaged.
5. **Be careful with power.** Avoid accidental shocks, discharges or explosions.
 - Before removing or servicing any part from the computer, turn the computer off and detach any power supplies.
 - When you want to unplug the power cord or any cable/wire, be sure to disconnect it by the plug head. Do not pull on the wire.
6. **Peripherals** – Turn off and detach any peripherals.
7. **Beware of static discharge.** ICs, such as the CPU and main support chips, are vulnerable to static electricity. Before handling any part in the computer, discharge any static electricity inside the computer. When handling a printed circuit board, do not use gloves or other materials which allow static electricity buildup. We suggest that you use an anti-static wrist strap instead.
8. **Beware of corrosion.** As you perform your job, avoid touching any connector leads. Even the cleanest hands produce oils which can attract corrosive elements.
9. **Keep your work environment clean.** Tobacco smoke, dust or other air-borne particulate matter is often attracted to charged surfaces, reducing performance.
10. **Keep track of the components.** When removing or replacing any part, be careful not to leave small parts, such as screws, loose inside the computer.

Cleaning

Do not apply cleaner directly to the computer, use a soft clean cloth.

Do not use volatile (petroleum distillates) or abrasive cleaners on any part of the computer.

(For Computer Models Supplied with Light Blue Cleaning Cloth) Some computer models in this series come supplied with a light blue cleaning cloth. To clean the computer case with this cloth follow the instructions below.

- Power off the computer and peripherals.
- Disconnect the AC/DC adapter from the computer.
- Use a little water to dampen the cloth slightly.
- Clean the computer case with the cloth.
- Dry the computer with a dry cloth, or allow it time to dry before turning on.
- Reconnect the AC/DC adapter and turn the computer on.



Power Safety Warning

Before you undertake any upgrade procedures, make sure that you have turned off the power, and disconnected all peripherals and cables (including telephone lines and power cord). It is advisable to also remove your battery in order to prevent accidentally turning the machine on.

Disassembly Steps

The following table lists the disassembly steps, and on which page to find the related information. **PLEASE PERFORM THE DISASSEMBLY STEPS IN THE ORDER INDICATED.**

To remove the Battery:

1. Remove the battery [page 2 - 5](#)

To remove the Keyboard:

1. Remove the keyboard [page 2 - 6](#)

To remove the HDD:

1. Remove the battery [page 2 - 5](#)
2. Remove the HDD [page 2 - 7](#)

To remove the System Memory:

1. Remove the battery [page 2 - 5](#)
2. Remove the HDD [page 2 - 7](#)
3. Remove the system memory [page 2 - 9](#)

To remove the M.2 SSD:

1. Remove the battery [page 2 - 5](#)
2. Remove the HDD [page 2 - 7](#)
3. Remove the SSD [page 2 - 10](#)

To remove the Wireless LAN Module:

1. Remove the battery [page 2 - 5](#)
2. Remove the HDD [page 2 - 7](#)
3. Remove the WLAN [page 2 - 11](#)

To remove the CCD Module:

1. Remove the battery [page 2 - 5](#)
2. Remove the HDD [page 2 - 7](#)
3. Remove the CCD module [page 2 - 13](#)

Removing the Battery

1. Turn the computer **off**, and turn it over.
2. Slide the latch **1** in the direction of the arrow (*Figure 1a*).
3. Slide the latch **2** in the direction of the arrow.
4. While holding the latch **2**, lift the battery **3** (*Figure 1b*) out of the compartment (*Figure 1c*).

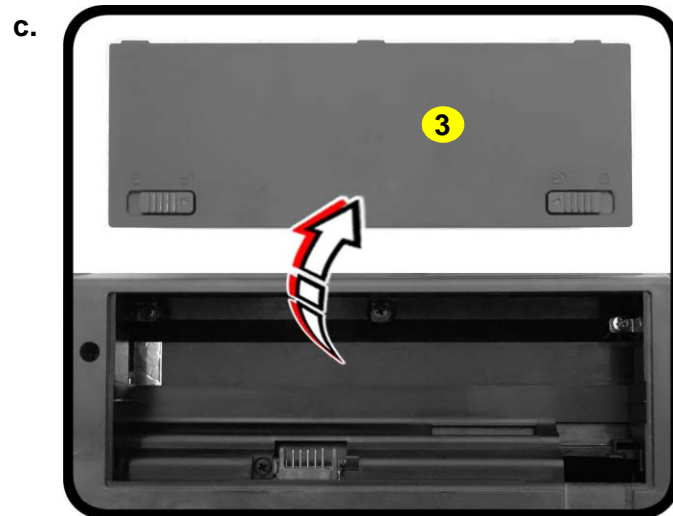
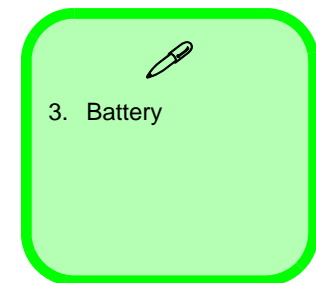

Figure 1
Battery Removal

- a. Slide the latch **1** in the direction of the arrow, and slide the latch **2** in the direction of the arrow.
- b. Lift the battery.
- c. Remove the battery.



Disassembly

Figure 2

Keyboard Removal

- Remove the screws from the bottom of the computer and then eject the keyboard using a special eject stick to push the keyboard out while releasing the keyboard as shown.
- Lift the keyboard up and disconnect the keyboard ribbon cable from the locking collar socket.
- Remove the keyboard.

Removing the Keyboard

- Turn **off** the computer, turn it over.
- Remove screws **1** - **2** from the bottom of the computer.
- Open it up with the LCD on a flat surface before pressing at point **3** to release the keyboard module (use the special eject stick **4** to do this) while releasing the keyboard in the direction of the arrow **5** as shown (**Figure 2a**).
- Carefully lift the keyboard **6** up, being careful not to bend the keyboard ribbon cable **7**. Disconnect the keyboard ribbon cable **7** from the locking collar socket by using a flat-head screwdriver to pry the locking collar pins **8** away from the base (**Figure 2b**).
- Carefully lift the keyboard **6** off the computer (**Figure 2c**).

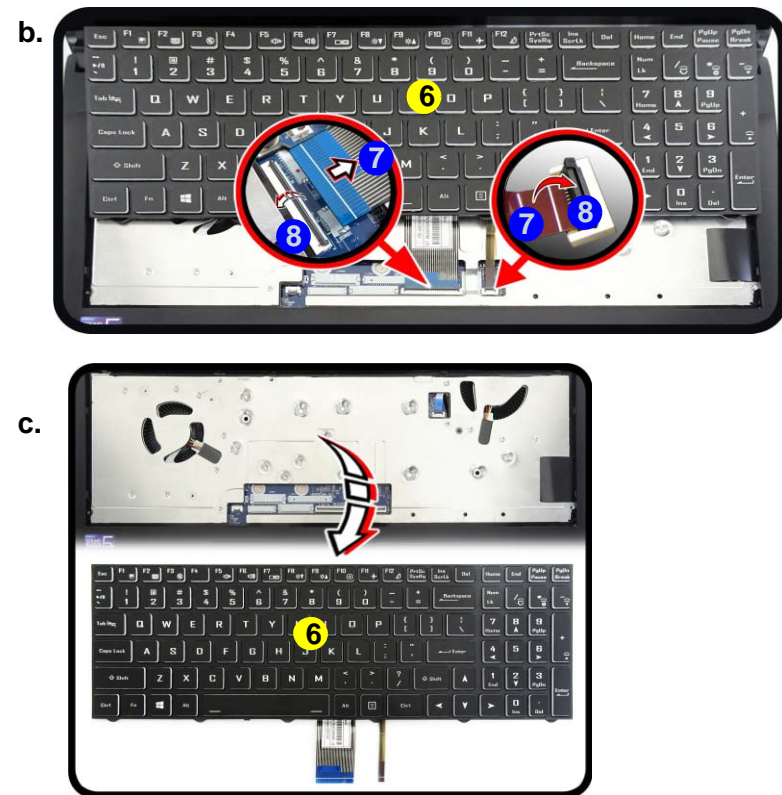
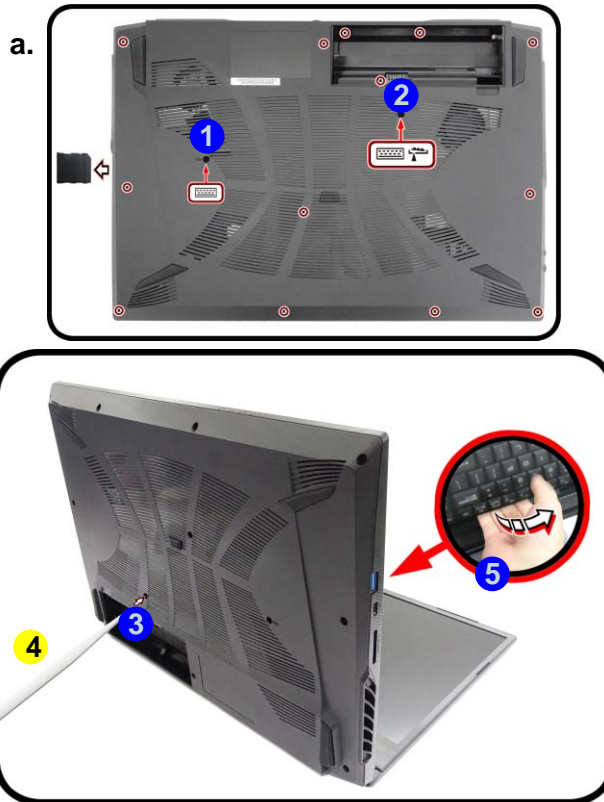

Re-inserting the Keyboard

When re-inserting the keyboard firstly, align the keyboard tabs at the bottom of the keyboard with the slots in the case.



- Eject Stick
- Keyboard

- 2 Screws

Removing the Hard Disk Drive

The hard disk drive can be taken out to accommodate other 2.5" serial (SATA) hard disk drives with a height of 7mm (h). Follow your operating system's installation instructions, and install all necessary drivers and utilities (as outlined in **Chapter 4 of the User's Manual**) when setting up a new hard disk.

Hard Disk Disassembly Process

1. Turn **off** the computer, and remove the battery ([page 2 - 5](#)).
2. Remove the SD card cover **1** and screws **2 - 14**, **but note that screw 4 and 6 needs to be remove using 3mm diameter - type screwdriver only (Figure 3a)**.
3. Carefully lift the bottom case **15** up from point **16** and remove it ([Figure 3b](#)).
4. The HDD will be visible at point **17** on the mainboard ([Figure 3c](#)).

Figure 3
HDD Assembly Removal

- Remove the SD card cover and screws.
- Remove the bottom case.
- Locate the HDD.

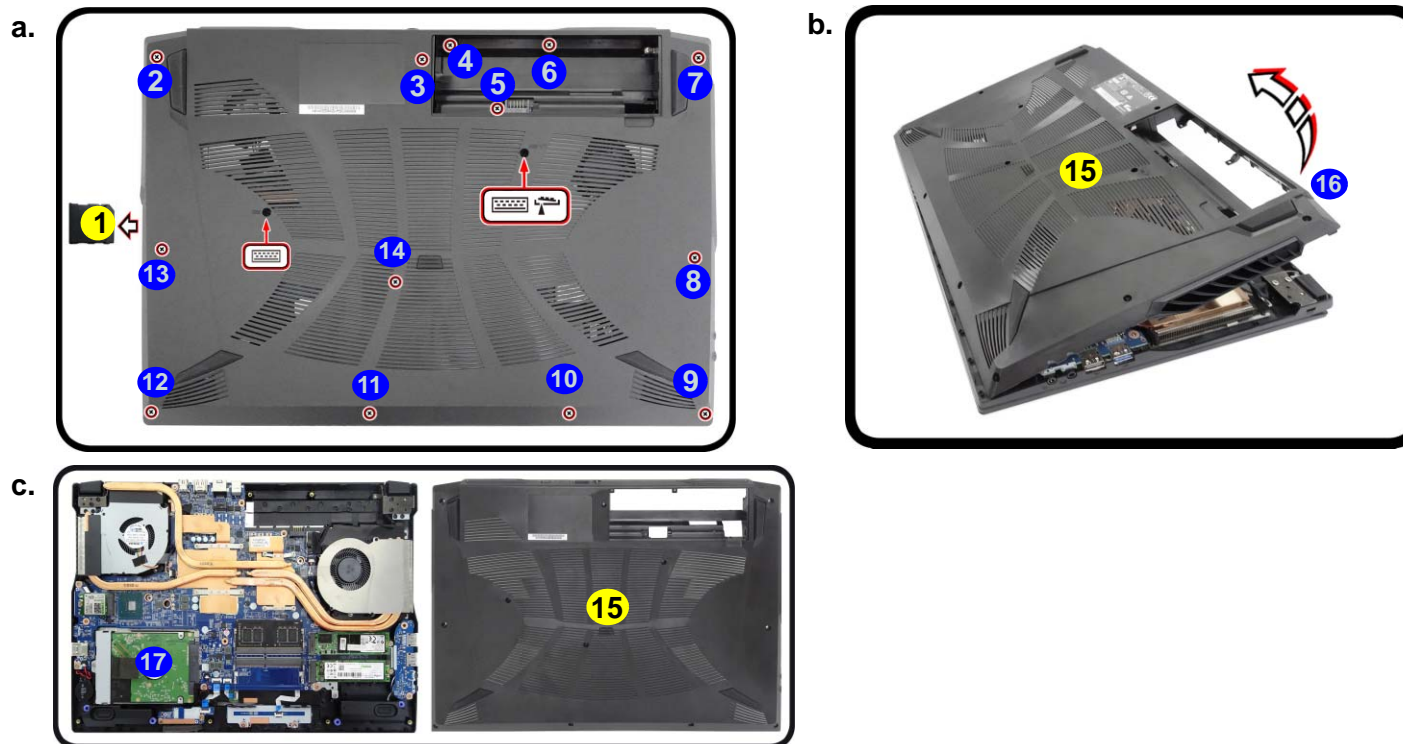



15. Bottom Case

- 13 Screws

Disassembly

Figure 4
**HDD Assembly
 Removal (cont'd.)**

- d. Remove the screws.
 e. Slightly lift and pull the HDD in the direction of the arrow.
 f. Lift the HDD assembly out of the bay.
 g. Remove the screws and bracket from the HDD.

5. Remove screws **18** from the HDD assembly (*Figure 4b*).
 6. Slightly lift and pull the hard disk assembly in the direction of arrow **19** (*Figure 4c*).
 7. Lift the hard disk assembly **20** out of the bay **21** (*Figure 4d*).
 8. Remove screws **22** - **23** and bracket **24** from the hard disk **25** (*Figure 4e*).
 9. Reverse the process to install a new hard disk (do not forget to replace the screws).

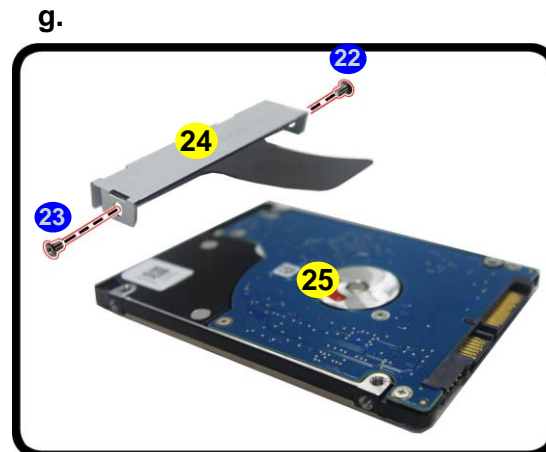
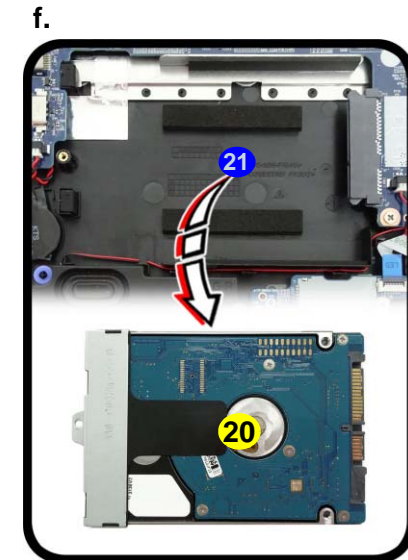
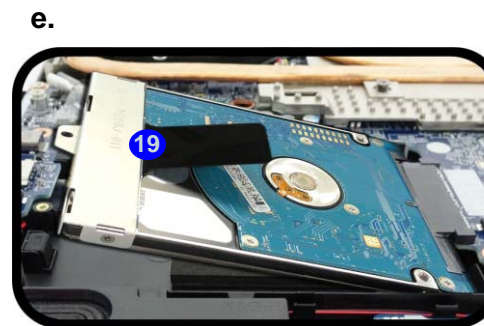
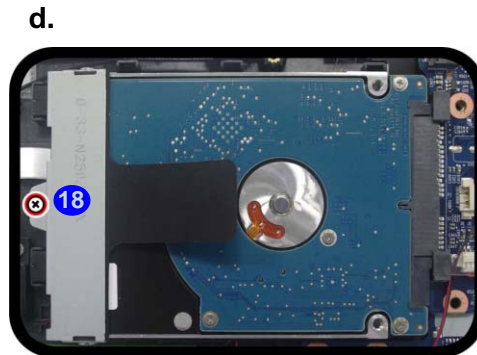

- 
20. HDD Assembly
 24. Bracket
 25. HDD

- 3 Screws



HDD System Warning

New HDD's are blank. Before you begin make sure:

You have backed up any data you want to keep from your old HDD.

You have all the CD-ROMs and FDDs required to install your operating system and programs.

If you have access to the internet, download the latest application and hardware driver updates for the operating system you plan to install. Copy these to a removable medium.

Removing the System Memory (RAM)

The computer has two memory sockets for 260 pin Small Outline Dual In-line Memory Modules (SO-DIMM) supporting DDR4 up to 2400 MHz. The main memory can be expanded up to 16GB. The total memory size is automatically detected by the POST routine once you turn on your computer.

Memory Upgrade Process

1. Turn **off** the computer, turn it over, remove the battery ([page 2 - 5](#)).
2. The RAM modules will be visible at point **1** on the mainboard ([Figure 5a](#)).
3. Gently pull the two release latches (**2** & **3**) on the sides of the memory socket in the direction indicated by the arrows ([Figure 5b](#)). The RAM module **4** will pop-up ([Figure 5c](#)), and you can then remove it.
4. Pull the latches to release the second module if necessary.
5. Insert a new module (**for only one module** - insert module in the top slot "J_DIMMB1" as shown in [Figure 5c](#)) by holding it at about a 30° angle and fit the connectors firmly into the memory slot.
6. The module will only fit one way as defined by its pin alignment. Make sure the module is seated as far into the slot as it will go. **DO NOT FORCE IT**; it should fit without much pressure.
7. Press the module in and down towards the mainboard until the slot levers click into place to secure the module.
8. Replace the bottom cover and the screws (see [page 2 - 7](#)).
9. Restart the computer to allow the BIOS to register the new memory configuration as it starts up.

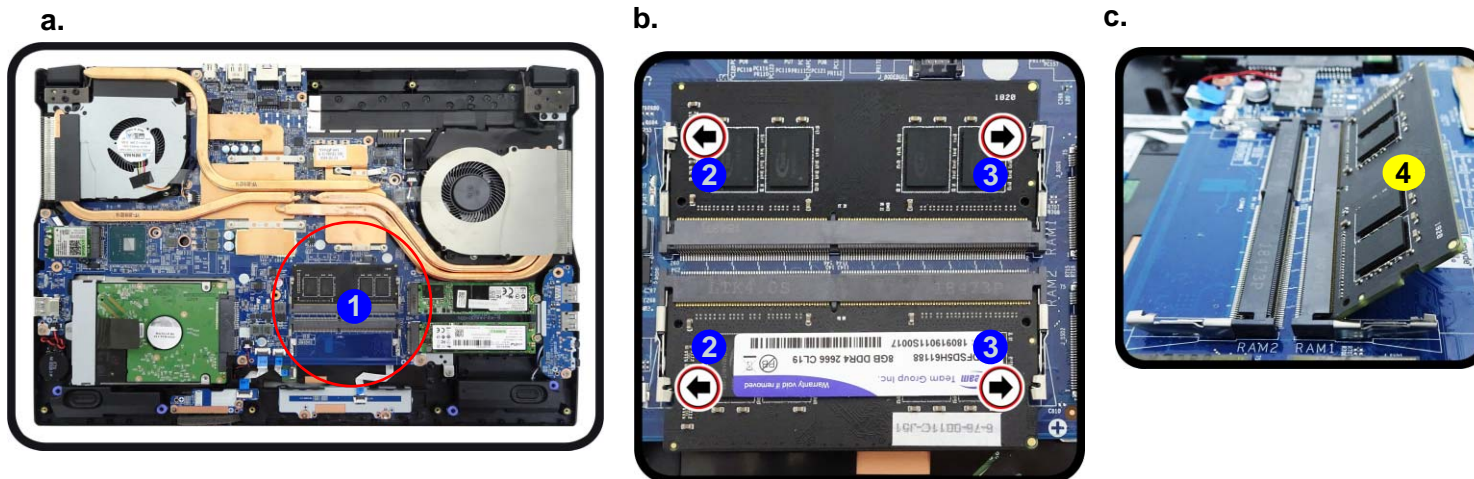

Figure 5
RAM Module Removal

- a. The RAM module(s) will be visible at point **1** on the mainboard.
- b. Pull the release latches.
- c. Remove the module.



Contact Warning

Be careful not to touch the metal pins on the module's connecting edge. Even the cleanest hands have oils which can attract particles, and degrade the module's performance.



4. RAM Module

Disassembly

Figure 6
M.2 SSD Module
Removal

- Locate the M.2 SSD.
- Remove the screw.
- The M.2 SSD module will pop up.

Removing the M.2 SSD Module

M.2 SSD Module Removal Procedure

- Turn off the computer, turn it over, remove the battery ([page 2 - 5](#)).
- The M.2 SSD module will be visible at point **1** on the mainboard ([Figure 6a](#)).
- Remove the screw **2** ([Figure 6b](#)).
- The M.2 SSD module **3** ([Figure 6c](#)) will pop-up, and you can remove it from the computer.

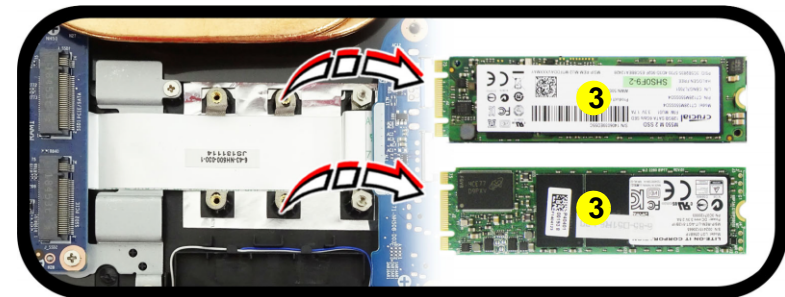

3.M2 SSD Module

- 1 Screw

Removing the Wireless LAN Module

1. Turn **off** the computer, turn it over, remove the battery ([page 2 - 5](#)).
2. The Wireless LAN module will be visible at point **1** on the mainboard ([Figure 7a](#)).
3. Remove the mylar cover **2** ([Figure 7b](#)).
4. Carefully disconnect the cables **3** & **4**, and then remove the screw **5** ([Figure 7c](#)).
5. The Wireless LAN module **6** ([Figure 7d](#)) will pop-up, and you can remove it from the computer.
6. Reverse the process to install a new module (do not forget to replace the mylar and screws while making sure that the cables are properly inserted as shown in [Figure 7c](#)).

Figure 7
Wireless LAN Module Removal

- Locate the WLAN.
- Remove the mylar cover.
- Disconnect the cables and remove the screw.
- The WLAN module will pop up.

Note: Make sure you reconnect the antenna cable to the “1 + 2” socket ([Figure 7b](#)).

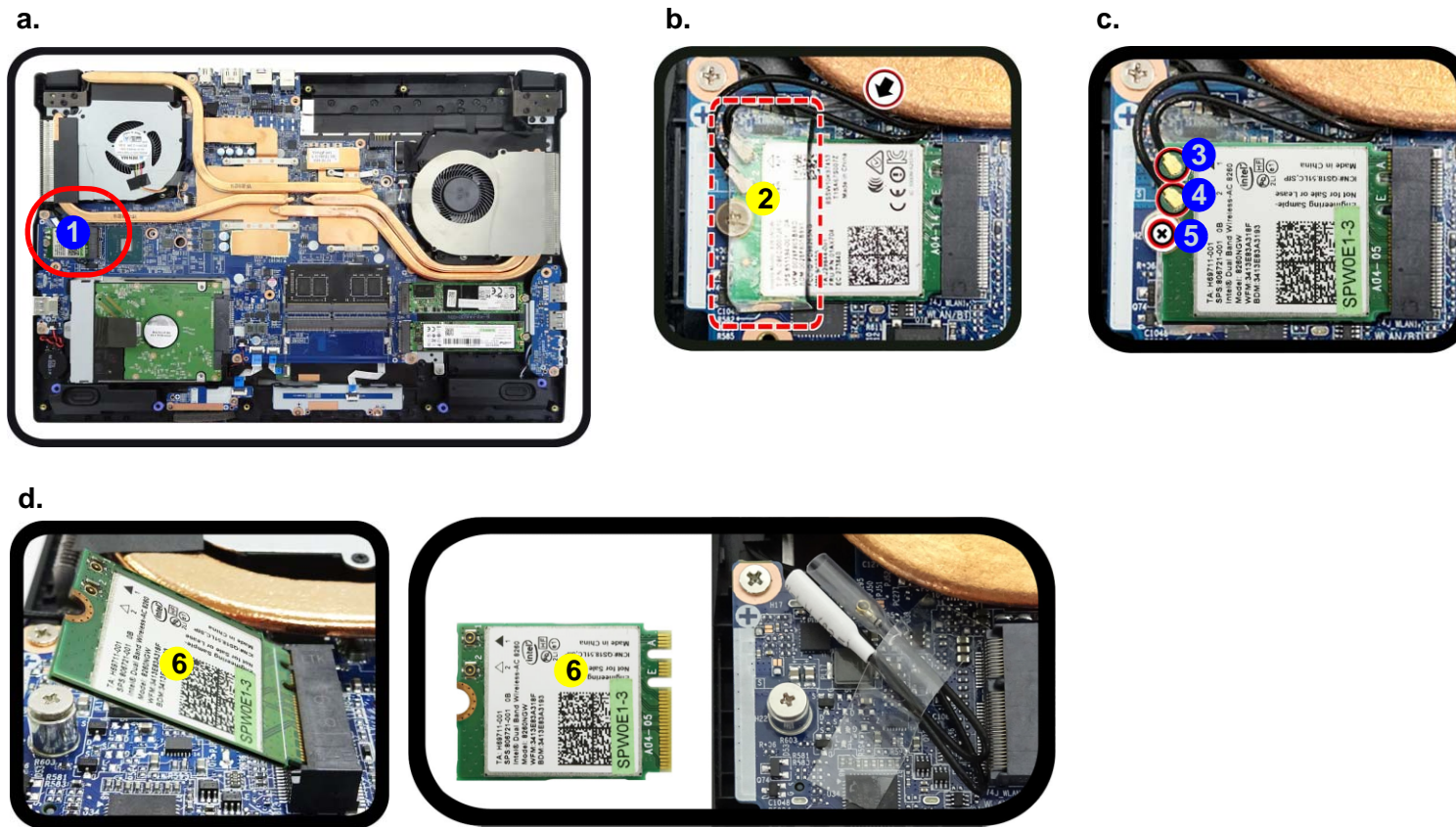



2. Mylar Cover
6. Wireless LAN Module

- 1 Screw

Wireless LAN, Combo Module Cables

Note that the cables for connecting to the antennae on WLAN, WLAN & Bluetooth Combo modules are not labelled. The cables/covers (each cable will have either a black or transparent cable cover) are color coded for identification as outlined in the table below.

Module Type	Antenna Type	Cable Color	Cable Cover Type
WLAN/WLAN & Bluetooth Combo	WM 1	Black	Transparent
	WM 2	Black	White

Cable 1 is usually connected to antenna 1 on the module, and cable 2 to antenna 2.

Removing the CCD

1. Turn **off** the computer, turn it over to remove the battery ([page 2 - 5](#)).
2. Lay the computer down on a flat surface with the top case up forming a 90 degree angle.
3. Carefully run your fingers around the inner frame of the LCD panel to lift at points **1** - **4** as indicated by the arrows ([Figure 8a](#)).
4. Remove the LCD front cover **5** ([Figure 8b](#)).

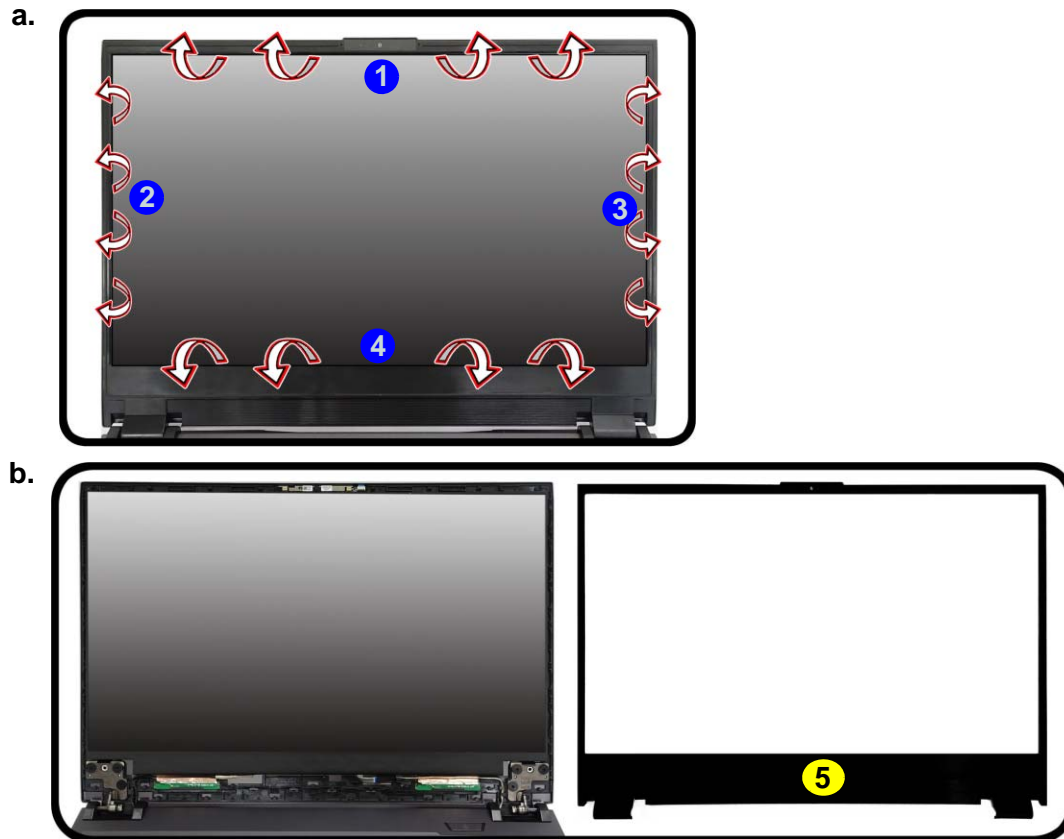

Figure 8
CCD Removal

- a. Carefully release the inner frame of the LCD panel at the points indicated by the arrows.
- b. Remove the LCD front cover.



Disassembly

Figure 9
CCD Removal
(cont'd)

- c. Disconnect the cable from the locking collar socket.
- d. Remove the CCD module.

5. Disconnect the cable **6** from the locking collar socket by using a flat-head screwdriver to pry the locking collar pins **7** away from the base (*Figure 9c*).
6. Remove the CCD module **8** (*Figure 9d*).
7. Reverse the process to install a new CCD module.

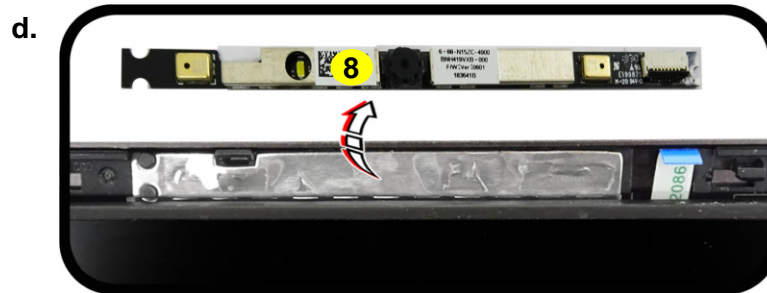

8. CCD Module

Appendix A:Part Lists

This appendix breaks down the *NH50RA / NH50RH / NH57RA / NH57RH* series notebook's construction into a series of illustrations. The component part numbers are indicated in the tables opposite the drawings.

Note: This section indicates the *manufacturer's* part numbers. Your organization may use a different system, so be sure to cross-check any relevant documentation.

Note: Some assemblies may have parts in common (especially screws). However, the part lists DO NOT indicate the total number of duplicated parts used.

Note: Be sure to check any update notices. The parts shown in these illustrations are appropriate for the system at the time of publication. Over the product life, some parts may be improved or re-configured, resulting in *new* part numbers.

Part List Illustration Location

The following table indicates where to find the appropriate part list illustration.

Table A - 1
**Part List Illustration
Location**

Part	NH50RA / NH50RH	NH57RA / NH57RH
Top	<i>page A - 3</i>	<i>page A - 4</i>
Bottom	<i>page A - 5</i>	
Main Board	<i>page A - 6</i>	
HDD	<i>page A - 7</i>	
LCD	<i>page A - 8</i>	<i>page A - 9</i>

Top (NH50RA / NH50RH)

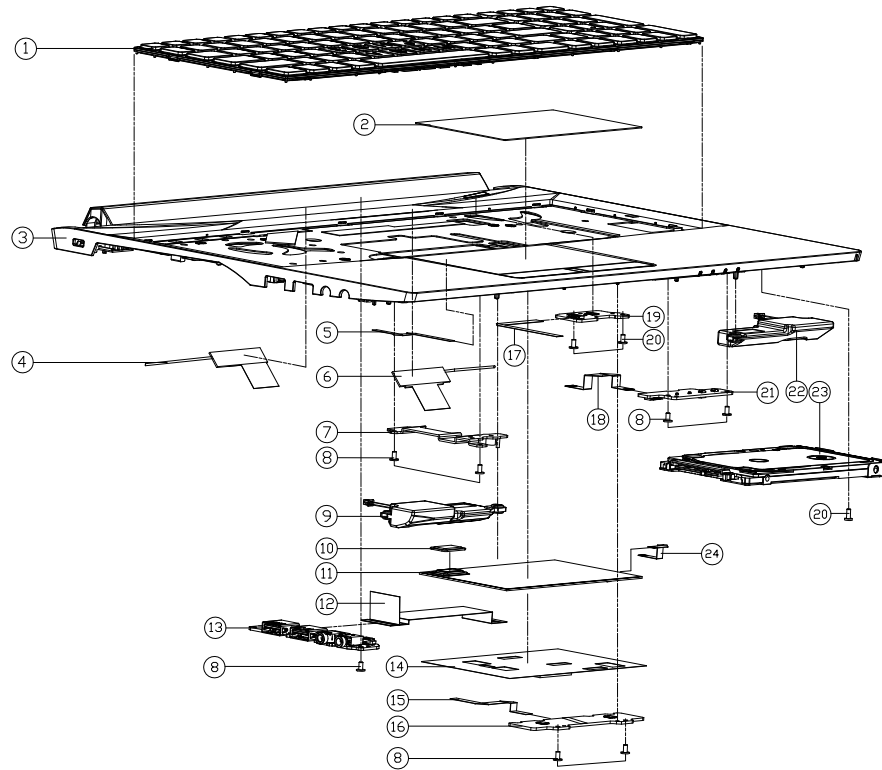

ITEM	PART NAME	PART NO	REMARK
1	KB FOR MULTI 15C BL KB US SERIES NH50E	6-NH50E2-KB-MCL-US	
2	W/O FP TP MYLAR AG32 APPEARANCE NH50E	6-40-NH502-031	ONLY FOR W/O FPC TOUCH PAD
2	W/FP TP MYLAR AG32 APPEARANCE NH50E	6-40-NH502-040	ONLY FOR W/FP SECURE PAD
3	TOP CASE MODULE NH50RA	6-39-NH5E2-012	
4	ANTENNA PEEM W/LIN JEM V4.2 PCB DL 400MM 2.6/5/5 V4.2-30MM NH50E	6-23-7NH50-040	
5	FFC CABLE FINGER TP TO MB L=50MM 3V 6PIN (QX) NH50E	6-43-NH500-061	ONLY FOR W/FP SECURE PAD
6	ANTENNA PEEM W/LIN JEM V4.1 PCB DL 400MM 2.6/5/5 V4.1-25MM NH50E	6-23-7NH50-030	
7	MB SUPPORT BRKT NH50E.D	6-33-NH502-021	
8	SCREW M2*4L KT NI ICT NY (OD=04.5,DT=0.8)	6-35-B1120-4RC	
9	SPK L-CABLE L25*44 2V 4P L50 MM DS-2314-M-32-HF N8701.H	6-23-5NB70-0L1	
10	TP W/O FP RUBBER (17.9*11.2*1.2T) SILICONE	6-47-N15Z2-090	
11	TOUCH PAD SYNAPTICS PTP TM-P3429 (00645MM) (V4BL) NH50E	6-49-N15Z3-011	ONLY FOR W/O FPC TOUCH PAD
11	SECURE PAD SYNAPTICS TM-P3428 (2C 00645MM) (V4BL) NH50E	6-49-N15Z3-021	ONLY FOR W/FP SECURE PAD
12	FFC CABLE AUDIO TO MB L=102MM 3V 40PIN (QX) NH50E	6-43-NH500-031	
13	AUDIO BOARD W/REDRIVER V2.0 NH50RH	6-77-NH5H6-D02	
13	AUDIO BOARD V2.0 NH50RA	6-77-NH5E8-D02	
14	TP MYLAR PET NH50E.D	6-40-NH502-021	
15	FFC CABLE CLICK TP TO L=61MM 3V 4PIN (QX) NH50E	6-43-NH500-051	
16	CLICK BOARD V1.0 NH50RH	6-77-NH5H2-D01	
16	CLICK BOARD V1.0 NH50RA	6-77-NH5E2-D01	
17	FFC CABLE POWER TO MB L=81MM 3V 4PIN (QX) NH50E	6-43-NH500-021	
18	FFC CABLE LED TO MB L=50MM 3V 12PIN (QX) NH50E	6-43-NH500-011	
19	POWER SW BOARD V1.0 NH50RH	6-77-NH5HS-D01	
19	POWER SW BOARD V1.0 NH50RA	6-77-NH5ES-D01	
20	SCREW M2*4L KT NI ICT NY (OD=04.5,DT=0.4)	6-35-B1120-4RE	
21	LED BOARD V2.0 NH50RH	6-77-NH5H4-D02	
21	LED BOARD V1.0A NH50RA	6-77-NH5E4-D01A	
22	SPK R-CABLE L25*44 2V 4P L 200MM DS-2314-M-32-HF N8701.H	6-23-5NB70-0R1	
23	W/O HDD ASS'Y NH50RA	6-79-NH50RA0J-010	
23	W/HDD ASS'Y NH50RA	6-79-NH50RA0J-020	
24	FFC CABLE TP TO MB L=36MM 3V 6PIN (QX) NH50E	6-43-NH500-041	

Figure A - 1
Top (NH50RA / NH50RH)

Top (NH57RA / NH57RH)

Figure 2
Top (NH57RA / NH57RH)

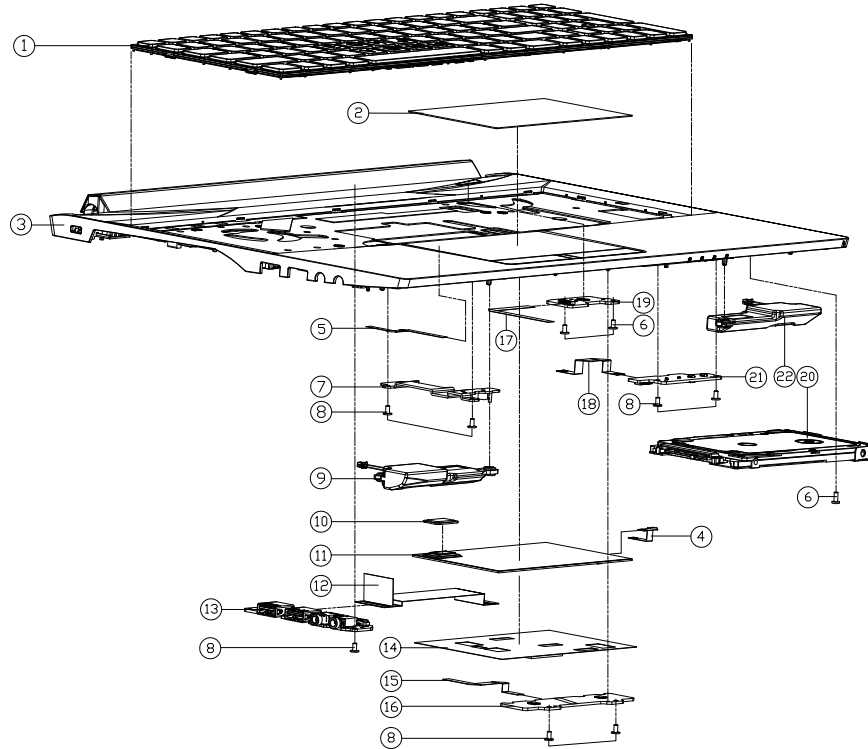

ITEM	PART NAME	PART NO	REMARK
1	KB FOR MULTI ISC BL KB US SERIES NH50ED	6-NH50ED-KB-MCL-US	FOR MULTI ISC BL KB SERIES
2	W/O FP TP MYLAR AG32 APPEARANCE NH50ED	6-40-NH502-031	ONLY FOR W/O FRTTOUCH PAD
2	W/FP TP MYLAR AG32 APPEARANCE NH50ED	6-40-NH502-040	ONLY FOR W/FP/SECURE PAD
3	TOP CASE MODULE NH50RA	6-39-NH5E2-012	
4	FFC CABLE TP TO MB L-36MM 3V 8PIN (GX) NH50ED	6-43-NH500-041	
5	FFC CABLE FINGER TP TO MB L-50MM 3V 6PIN (GX) NH50ED	6-43-NH500-061	ONLY FOR W/FP/SECURE PAD
6	SCREW M2x4L K1 NI ICT NY (DD=84.5,DT=0.4)	6-35-B1120-4RE	
7	MB SUPPORT BRKT NH50ED	6-33-NH502-021	
8	SCREW M2x4L K1 NI ICT NY (DD=84.5,DT=0.8)	6-35-B1120-4RC	
9	SPK L-CABLE L25x44 2W 4F L 150 MM IS-2514-ML-32-HF N0701J1	6-23-5NB70-0L1	
10	TP W/O FP RUBBER (17.9x11.2x1.2T) SILICONE	6-47-N15Z2-090	
11	TOUCH PAD SYNAPTICS PTP TM-P3429 (00846MM) (WHL) N50U	6-49-N15Z3-011	ONLY FOR W/O FRTTOUCH PAD
11	SECURE PAD SYNAPTICS TM-P3429 (00846MM) (WHL) N50U	6-49-N15Z3-021	ONLY FOR W/FP/SECURE PAD
12	FFC CABLE AUDIO TO MB L-102MM 3V 40PIN (GX) NH50ED	6-43-NH500-031	
13	AUDIO BOARD W/REDRIVER V2.0 NH50RH	6-77-NH5H6-D02	
13	AUDIO BOARD V2.0 NH50RH	6-77-NH5H8-D02	
13	AUDIO BOARD V2.0 NH50RA	6-77-NH5E8-D02	
14	TP MYLAR PET NH50ED	6-40-NH502-021	
15	FFC CABLE CLICK TO TP L-61MM 3V 4PIN (GX) NH50ED	6-43-NH500-051	
16	CLICK BOARD V1.0 NH50RH	6-77-NH5H2-D01	
16	CLICK BOARD V1.0 NH50RA	6-77-NH5E2-D01	
17	FFC CABLE POWER TO MB L-80MM 3V 4PIN (GX) NH50ED	6-43-NH500-021	
18	FFC CABLE LED TO MB L-50MM 3V 12PIN (GX) NH50ED	6-43-NH500-011	
19	POWER SW BOARD V1.0 NH50RH	6-77-NH5H5-D01	
19	POWER SW BOARD V1.0 NH50RA	6-77-NH5E5-D01	
20	W/O HDD ASS'Y NH50RA	6-79-NH50RA0J-010	
20	W/HDD ASS'Y NH50RA	6-79-NH50RA0J-020	
21	LED BOARD V2.0 NH50RH	6-77-NH5H4-D02	
21	LED BOARD V1.0A NH50RA	6-77-NH5E4-D01A	
22	SPK R-CABLE L25x44 2W 4F L 200MM IS-2514-ML-32-HF N0701J1	6-23-5NB70-0R1	

Bottom

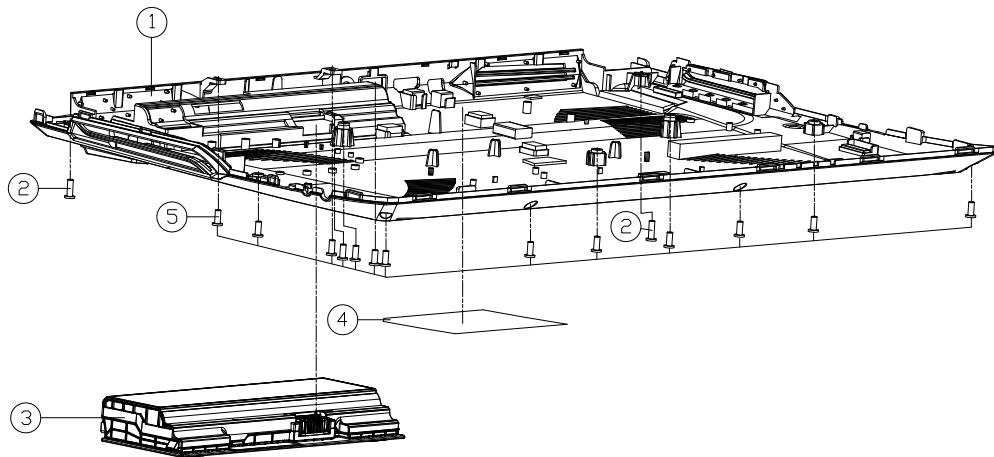

ITEM	PART NAME	PART NO	REMARK
1	BOTTOM CASE MODULE NH55RAQ	6-39-NH553-A12	
1	BOTTOM CASE MODULE NH58RAQ-F	6-39-NH583-R11-F	
2	SCREW M2.5*BL KI BK/Z NY ICT	6-35-B6125-8R0	
3	IMP 5 LI NAVIGASIVAMA KIP SPYISI QANACO PANGAOR AN MASEI	6-87-NH505-41C01	
3	IMP 5 LI NAVIGASIVAMA KIP SETACAG QANACO SHENORU MASEI	6-87-NH505-42D01	
3	IMP 5 LI NAVIGASIVAMA KIP SETACAG QANACO SHENORU QZAMORAN	6-87-NH505-42D00	
3	IMP 5 LI NAVIGASIVAMA KIP SPYISI QANACO PANGAOR AN QZAMORAN	6-87-NH505-41F00	
3	IMP 5 LI NAVIGASIVAMA KIP SPYISI QANACO PANGAOR AN QZAMORAN	6-87-NH505-41D00	
4	PRODUCT LABEL FOR NH50RH	6-45-NH50RH03-010	
4	PRODUCT LABEL FOR NH55RHQ	6-45-NH55RHQ3-010	
4	PRODUCT LABEL FOR NH57RH	6-45-NH57RH03-010	
4	PRODUCT LABEL FOR NH58RHQ	6-45-NH58RHQ3-010	
4	PRODUCT LABEL FOR NH50RA	6-45-NH50RA03-010	
4	PRODUCT LABEL FOR NH55RAQ	6-45-NH55RAQ3-010	
4	PRODUCT LABEL FOR NH55RAQ-HM	6-45-NH55RAQHM-010	
4	PRODUCT LABEL FOR NH57RA	6-45-NH57RA03-010	
4	PRDDUCT LABEL FOR NH58RAQ	6-45-NH58RAQ3-010	
4	PRODUCT LABEL FOR NH58RAQ-F	6-45-NH58RAQF-010	
4	PRDCT LABEL FOR NH58RHQF AS VAGI/5-FRONT MASEI-F	6-45-NH58RHQF-AY0	
4	PRDCT LABEL FOR NH58RHQF AS VAGI/5-FRONT MASEI-F	6-45-NH58RHQF-AY4	
5	SCREW M2.5*6L K BZ ICT NY	6-35-82125-6RA	

Figure A - 3
Bottom

HDD

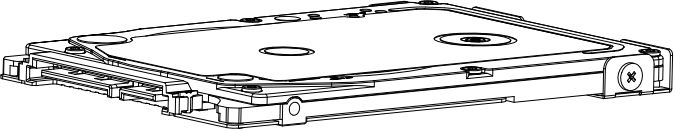
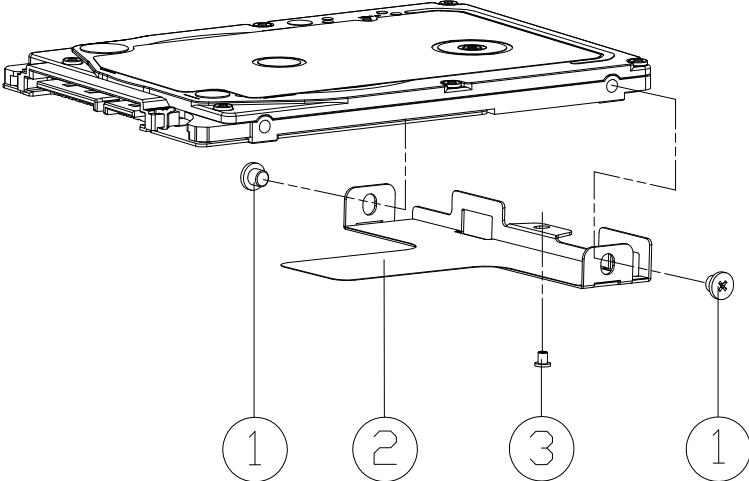

ITEM	PART NAME	PART NO	REMARK
1	SCREW M3*3.0L KI NI ICT NY	6-35-B1130-3R5	
2	HDD BKT 7MM SECC T=0.5 N250LU	6-33-N250J-011	
3	SCREW M2*4L KI NI ICT NY (DD=04.5,DT=08)	6-35-B1120-4RC	

Figure A - 5
HDD

LCD (NH57RA / NH57RH)

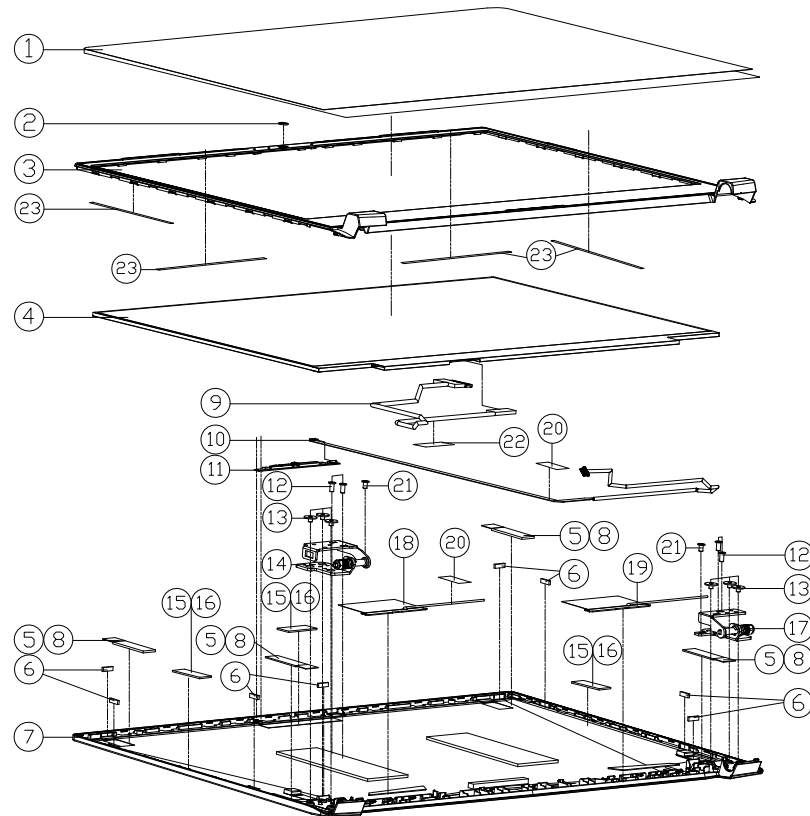

ITEM	PART NAME	PART NO	REMARK
1	LCD PROTECT MYLAR BOPP N150ZU	6-40-N15Z8-010	
2	CCD LENS PMMA (DIAMETER 3.6MM) (MPI) P970EN	6-42-P97N1-011	
3	LCD FRONT COVER MODULE NH50ED	6-39-NH501-012	
4	LCD NS6' FHD/VVA/N7/NDN G7/CEP DIMOLUX NIS6KE-ENI (LED 2.6MM)	6-50-LBB26-V020	
4	LCD NS6' FHD/PS/PA4R2/SV G-SYNC/N7/NDN G7/CEP LG LP56W6G-SPR2 (LED 2.6MM)	6-50-LBB26-L121	
4	LCD NS6' FHD/NDN G7/CEP DIMOLUX NIS6KEA-EAS (REV.C1) LED 3.2MM	6-50-LBB32-V002	
4	LCD NS6' FHD/PS/NA/NDN G7/CEP LG LP56W6G-SPR1 (LABLED) LED 3.2MM	6-50-LBB32-L016	
5	LALATAPE FOR 026 PANEL (40*10*1.2T) N232WU	6-47-N23U1-010	FDR 6-50-LBB32-V002 6-50-LBB32-L016
6	LCD RUBBER (8*2.5*1.45T) SILICON BLACK NH58EDQ	6-47-NH581-041	
7	BACK COVER MODULE NH57ED	6-39-NH571-022	
8	LALATAPE FOR 026 PANEL (40*10*1.8T) N140WU	6-47-N1401-010	FDR 6-50-LBB26-V020 6-50-LBB26-L121
9	WIRE CABLE FOR CEP 300MM 30V 1 30 PIN GHTLV CON:V0-A30LPSD PRIDEF	6-43-PB501-031-2N	
9	WIRE CABLE FOR CEP 4K 300MM 15V 30PIN COM:ALS COM:HLN002-HF N058U	6-43-N85H1-010-2S	
10	CCD CABLE L=550MM 30V 8PIN (HL) ADD MARK LABEL NH50CD	6-43-NH50T-011	
11	INK CARTRIDGE (BLACK) FOR 026/026/026/026 IN 80 DOTS PER INCH WHITE-LED V03-N0000000000000000	6-88-N15ZC-5100	OPTION
11	INK CARTRIDGE (CYAN) FOR 026/026/026/026 IN 80 DOTS PER INCH WHITE-LED V03-N0000000000000000	6-88-N15ZC-4900	OPTION
12	.SCREW M2.5*6L K BZ ICT NY	6-35-82125-6RA	
13	SCREW M2.5*2.5L KI BK/2 ICT NY(Ø8,T=0.6)	6-35-B6125-2R5	
14	HINGE L MODULE NH57ED	6-33-NH571-L00	
15	LCD SPONGE (SM55 25*10*1T) NH55EDQ	6-47-0019A-25R	FDR 6-50-LBB32-L016 6-50-LBB32-V002
16	LCD SPONGE (SM55 25*10*1.5T) NH55EDQ	6-47-0019A-25Q	FDR 6-50-LBB26-V020 6-50-LBB26-L121
17	HINGE R MODULE NH57ED	6-33-NH571-R00	
18	ANTENNA (SLIT) IPEX4 W/LAN WGT W/2 PCB DL 2.4G/5G 450MM NH57ED	6-23-7NH57-020	
19	ANTENNA (SLIT) IPEX4 W/LAN WGT W/1 PCB DL 2.4G/5G 250MM NH57ED	6-23-7NH57-010	
20	TAPE MYLAR TRANSPARENT (20*10*0.05) P180HM	6-40-P1803-020	
21	SCREW M2.5*4L (D=4.6,T=0.8) KI NI ICT NY	6-35-B1125-4RA	
22	ACETATE TAPE (32*10*0.2T) N141WU	6-40-N1411-020	FDR 6-50-LBB26-V020 6-50-LBB32-L016
23	FRONT COVER GLUE (NETTO 5000 135*3*0.15) FOR W655S2	6-40-W6551-040	

Figure A - 7
LCD (NH57RA / NH57RH)



Appendix B: Schematic Diagrams

This appendix has circuit diagrams of the *NH50RA / NH50RH / NH57RA / NH57RH* notebook's PCB's. The following table indicates where to find the appropriate schematic diagram.

Diagram - Page	Diagram - Page	Diagram - Page
<i>System Block Diagram - Page B - 2</i>	<i>PCH 1/9 - Page B - 25</i>	<i>1.05DX_VCCSTG/VCCSFR_OC - Page B - 48</i>
<i>Processor 1/6 - Page B - 3</i>	<i>PCH 2/9 - Page B - 26</i>	<i>VCCGT & VCCSA Output Stage - Page B - 49</i>
<i>Processor 2/6 - Page B - 4</i>	<i>PCH 3/9 - Page B - 27</i>	<i>AC_In, Charger - Page B - 50</i>
<i>Processor 3/6 - Page B - 5</i>	<i>PCH 4/9 - Page B - 28</i>	<i>NVVDD1 - Page B - 51</i>
<i>Processor 4/6 - Page B - 6</i>	<i>PCH 5/9 - Page B - 29</i>	<i>NVVDD2 - Page B - 52</i>
<i>Processor 5/6 - Page B - 7</i>	<i>PCH 6/9 - Page B - 30</i>	<i>PEX_VDD - Page B - 53</i>
<i>Processor 6/6 - Page B - 8</i>	<i>PCH 7/9 - Page B - 31</i>	<i>FBVDDQ - Page B - 54</i>
<i>DDR4 CHA SO-DIMM - Page B - 9</i>	<i>PCH 8/9 - Page B - 32</i>	<i>IV8_RUN/AON - Page B - 55</i>
<i>DDR4 CHB SO-DIMM - Page B - 10</i>	<i>PCH 9/9 - Page B - 33</i>	<i>Audio Board - Page B - 56</i>
<i>VGA PCI Express - Page B - 11</i>	<i>M.2 Card - Page B - 34</i>	<i>NH50 PW Board - Page B - 57</i>
<i>VGA Frame Buffer Interface - Page B - 12</i>	<i>M.2 WLAN+BT - Page B - 35</i>	<i>Hall Sensor Board - Page B - 58</i>
<i>Frame Buffer A - Page B - 13</i>	<i>USB Charger - Page B - 36</i>	<i>Click Board - Page B - 59</i>
<i>Frame Buffer A - Page B - 14</i>	<i>Card Reader / LAN RTL8411B - Page B - 37</i>	<i>LED Board - Page B - 60</i>
<i>Frame Buffer B - Page B - 15</i>	<i>HDD, Click TP, Audio, Hall Con. - Page B - 38</i>	<i>NH70 PW Board - Page B - 61</i>
<i>Frame Buffer B - Page B - 16</i>	<i>LED, CCD, TPM, Power SW Con. - Page B - 39</i>	<i>Audio Codec - Page B - 62</i>
<i>VGA I/O - Page B - 17</i>	<i>KBC-ITE IT5570 - Page B - 40</i>	<i>Power Measurement - Page B - 63</i>
<i>NVIDIA Power Sequence - Page B - 18</i>	<i>RGB KB Only - Page B - 41</i>	<i>Power Sequence - Page B - 64</i>
<i>NVIDIA GPIO Level Shift - Page B - 19</i>	<i>5V, 5VS, 3.3V, 3.3VS - Page B - 42</i>	<i>Audio Board - Page B - 65</i>
<i>VGA PWR / GND - Page B - 20</i>	<i>VDD1.05V, VCCIO - Page B - 43</i>	
<i>VGA NVVDD Coupling - Page B - 21</i>	<i>VDD3, VDD5 - Page B - 44</i>	
<i>MDP - Page B - 22</i>	<i>DDR 1.2V / 0.6VS, 2.5V - Page B - 45</i>	
<i>Panel, Inverter - Page B - 23</i>	<i>VCore Output Stage - Page B - 46</i>	
<i>HDMI - Page B - 24</i>	<i>VCC_Core & VCCGT - Page B - 47</i>	

Table B - 1
**SCHEMATIC
DIAGRAMS**



Version Note

The schematic diagrams in this chapter are based upon version 6-7P-NH5E6-002. If your mainboard (or other boards) are a later version, please check with the Service Center for updated diagrams (if required).

System Block Diagram

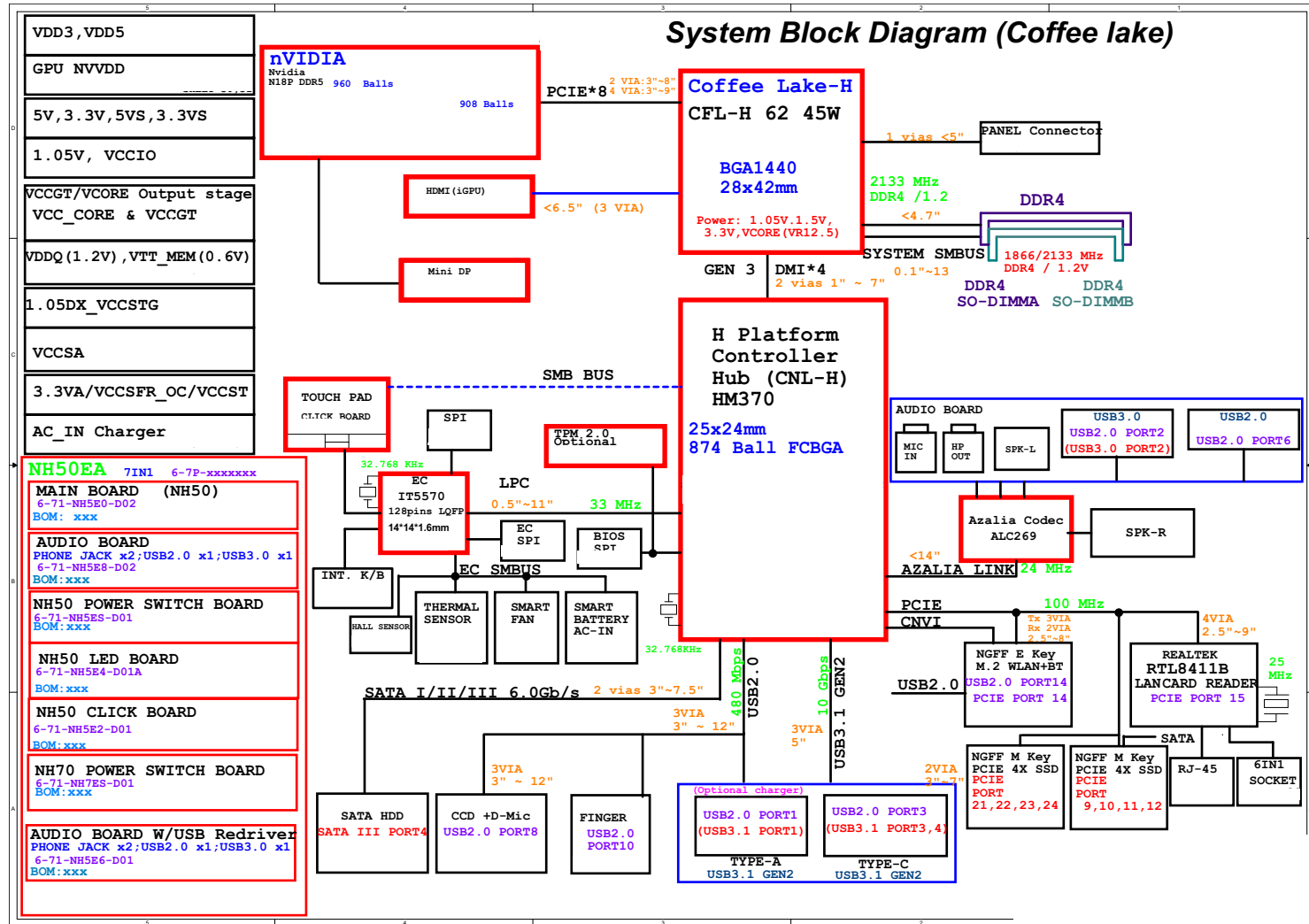

Sheet 1 of 64
System Block
Diagram

Processor 1/6

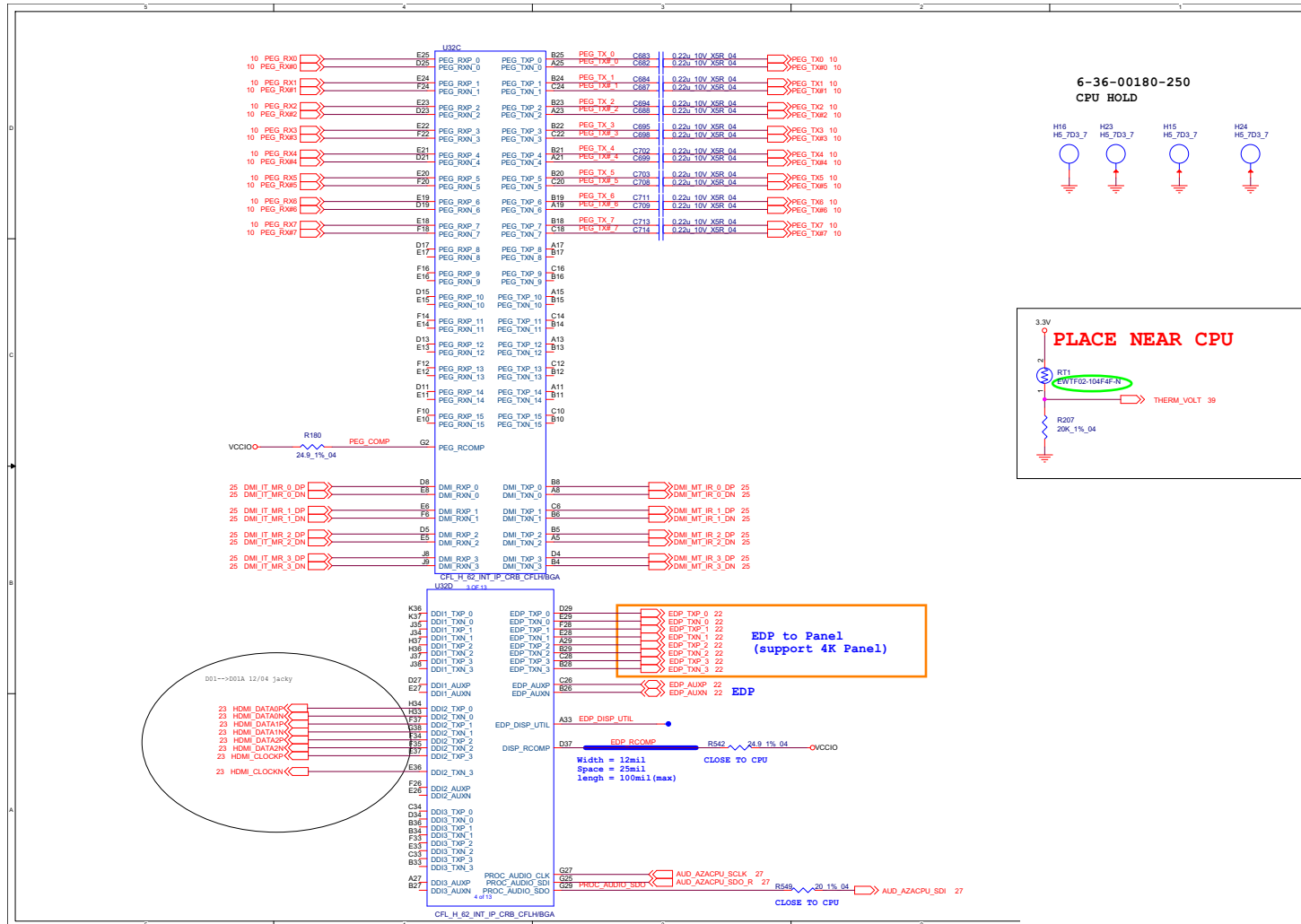

Sheet 2 of 64
Processor 1/6

Processor 2/6

B.Schematic Diagrams

Sheet 3 of 64
Processor 2/6

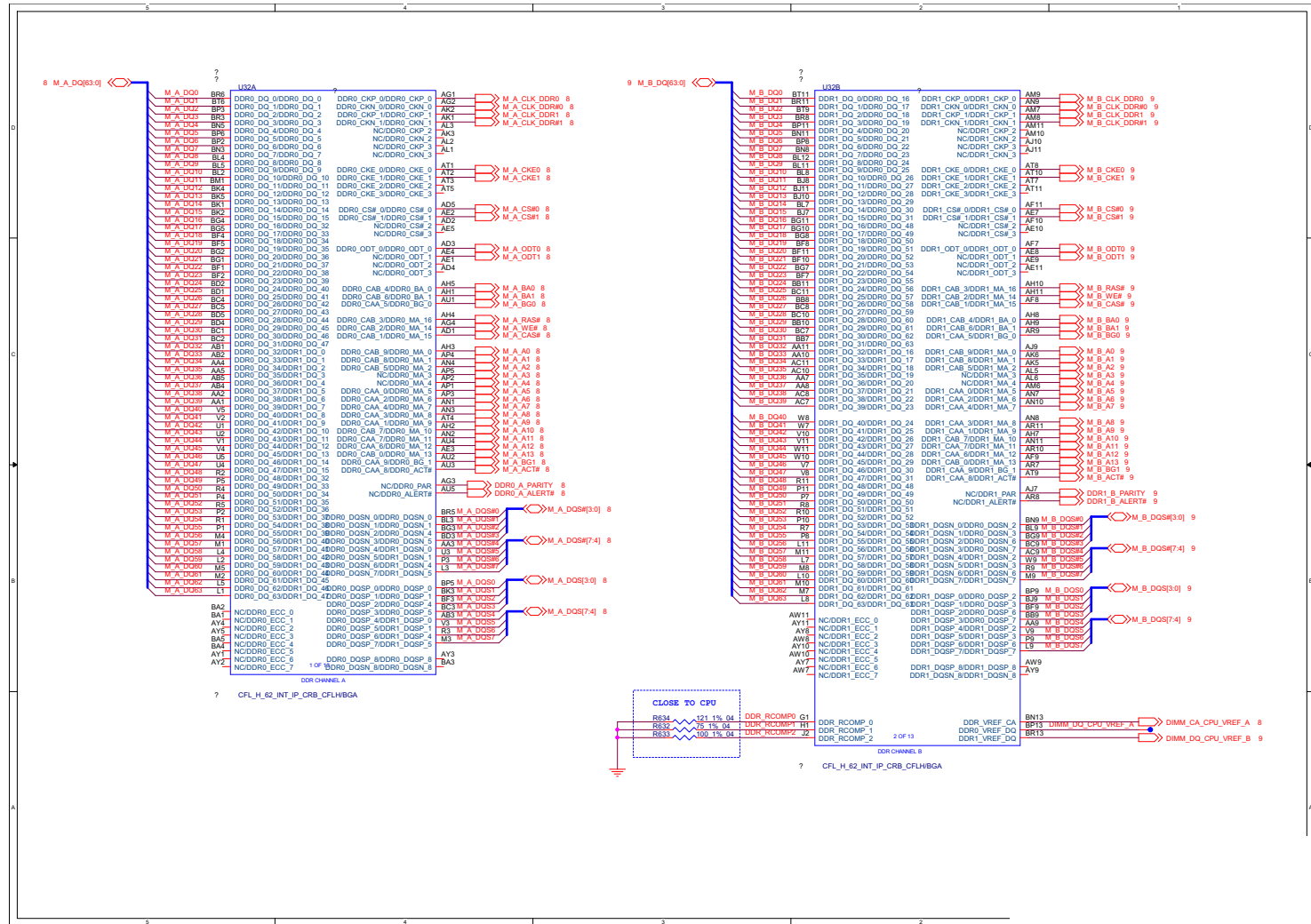

Processor 3/6

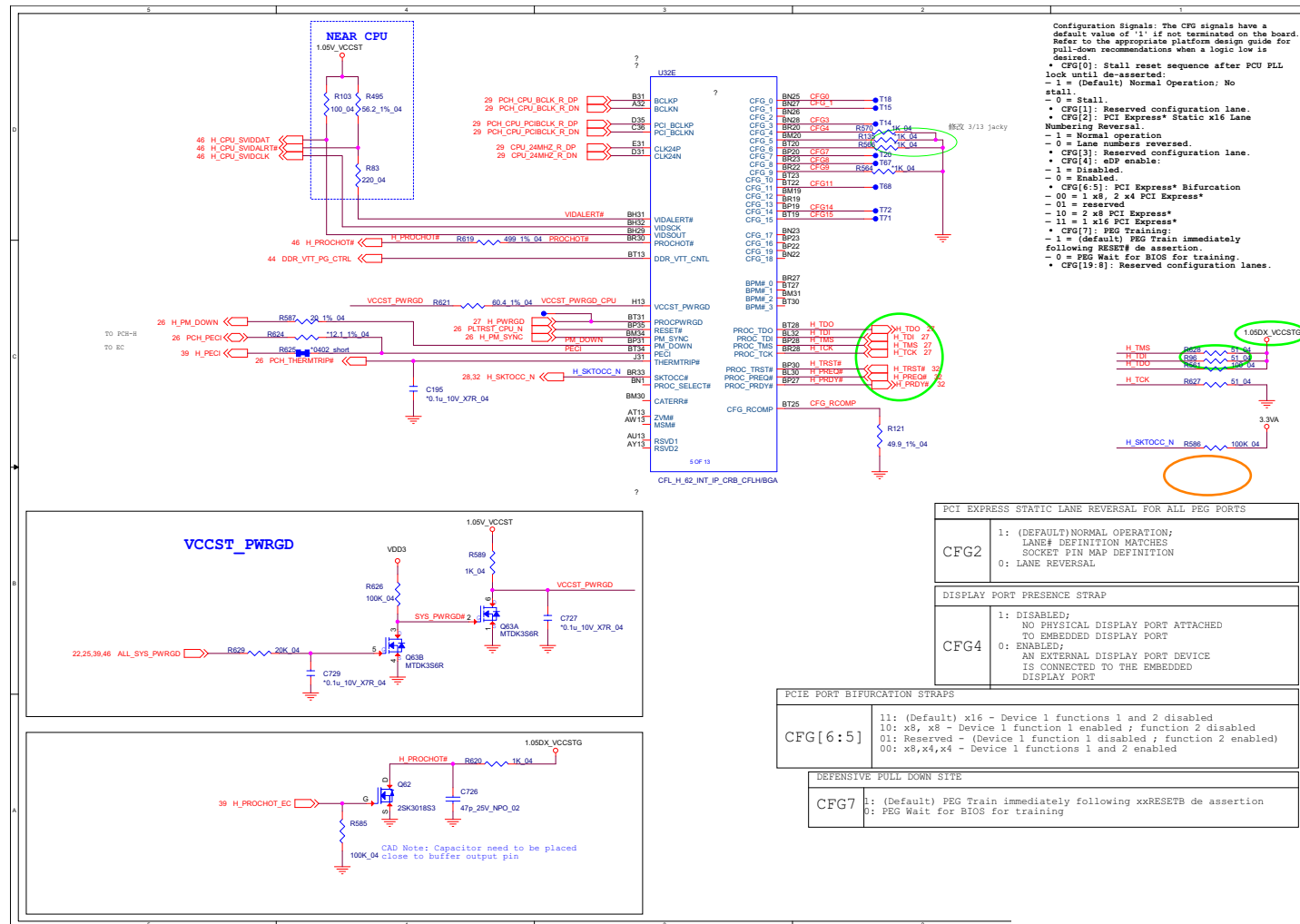

Sheet 4 of 64
Processor 3/6

Processor 4/6

Sheet 5 of 64
Processor 4/6

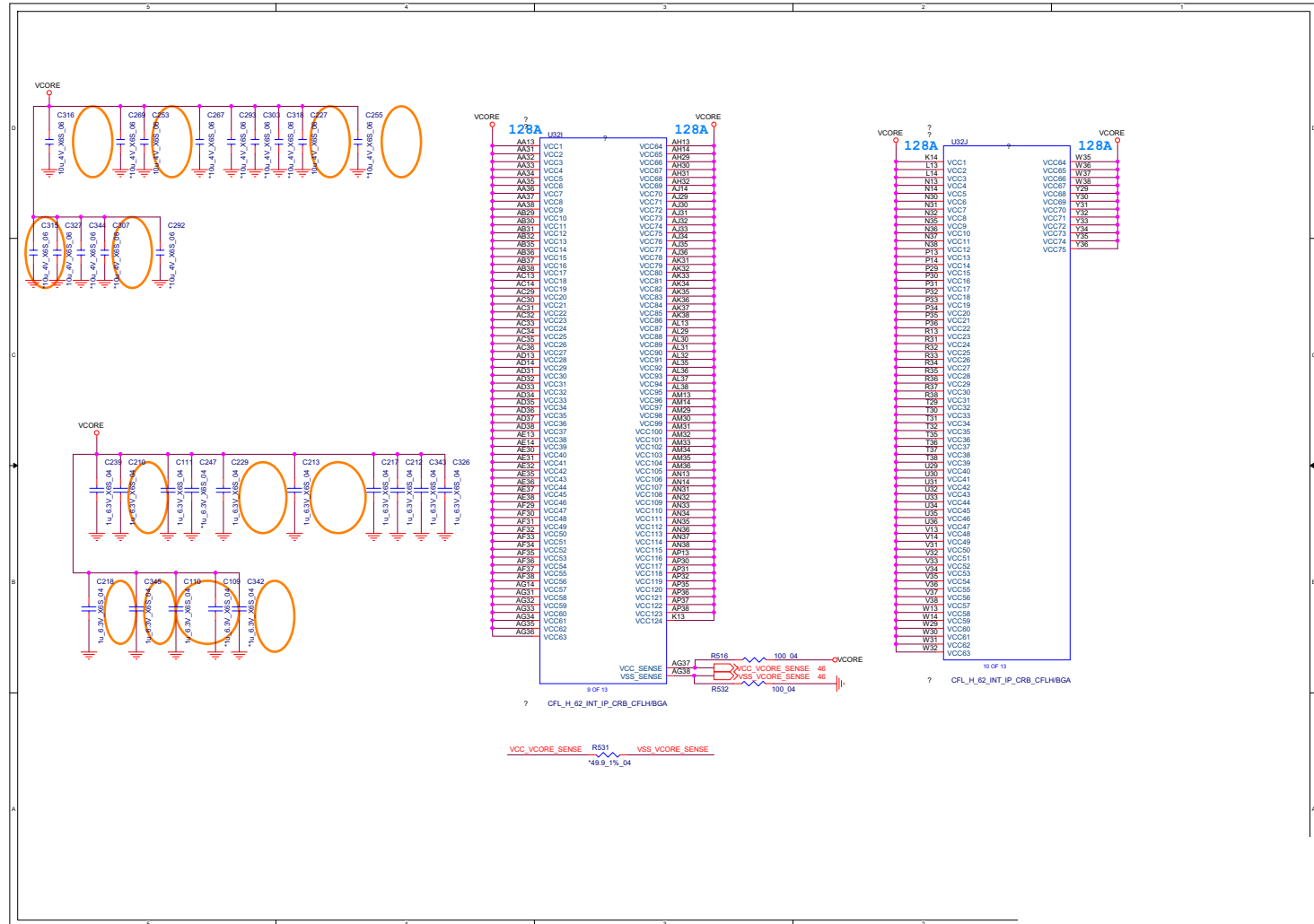

Processor 5/6

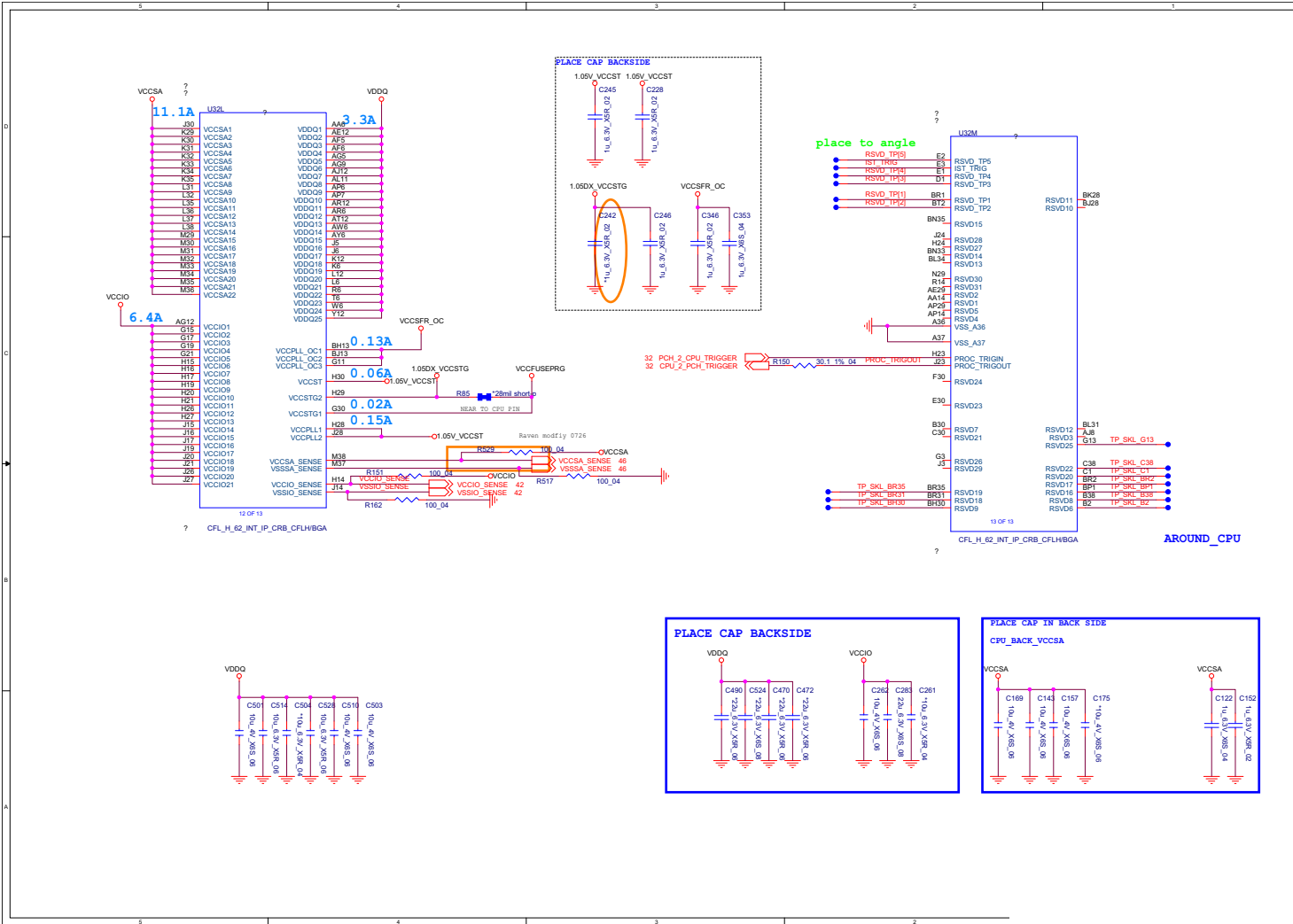

Sheet 6 of 64
Processor 5/6

B.Schematic Diagrams

Processor 6/6

Sheet 7 of 64
Processor 6/6

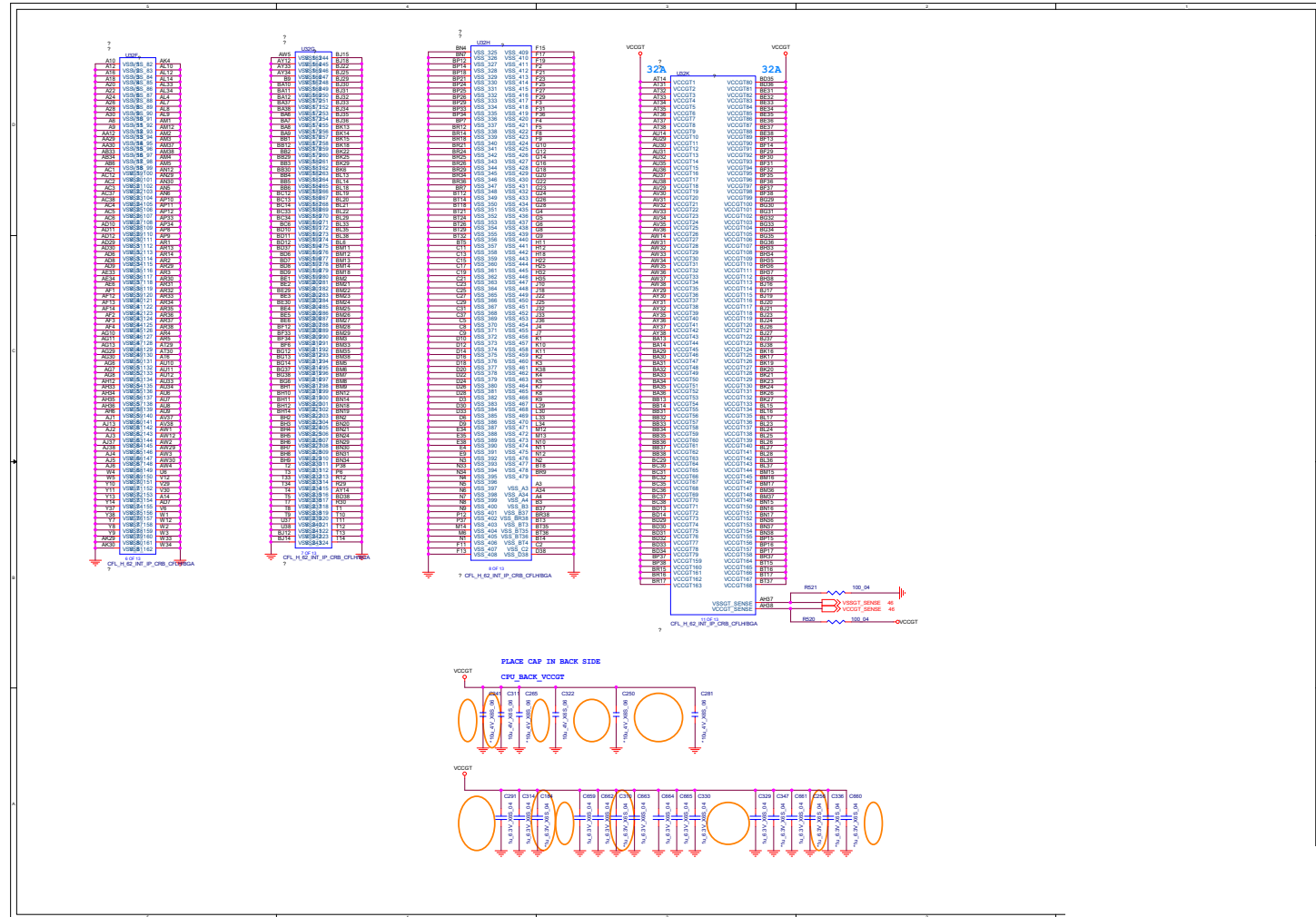

DDR4 CHA SO-DIMM

B.Schematic Diagrams

Channel A SO-DIMM 0 [RAM1]

PLACE THE CAP WITHIN 200 MILS FROM THE SODIMM
9.27 DDR4_DRAMRST# >> DDR4_DRAMRST#

PLACE THE CAP CLOSE TO SODIMM
DDR_VREFCA_CHA_DIMM
C487
0.1u_10V_XTR_04

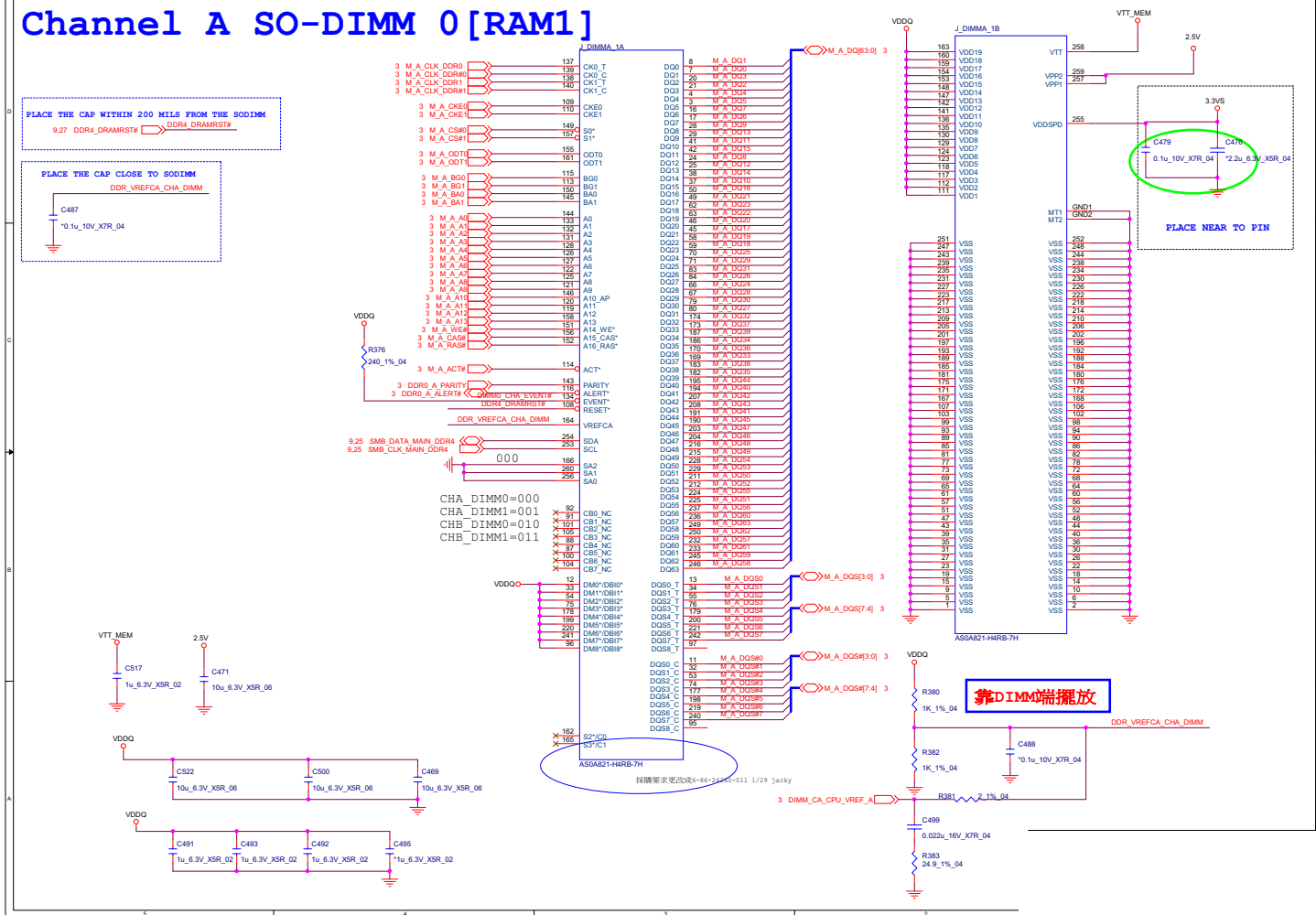

Sheet 8 of 64
DDR4 CHA SO-DIMM

Frame Buffer A

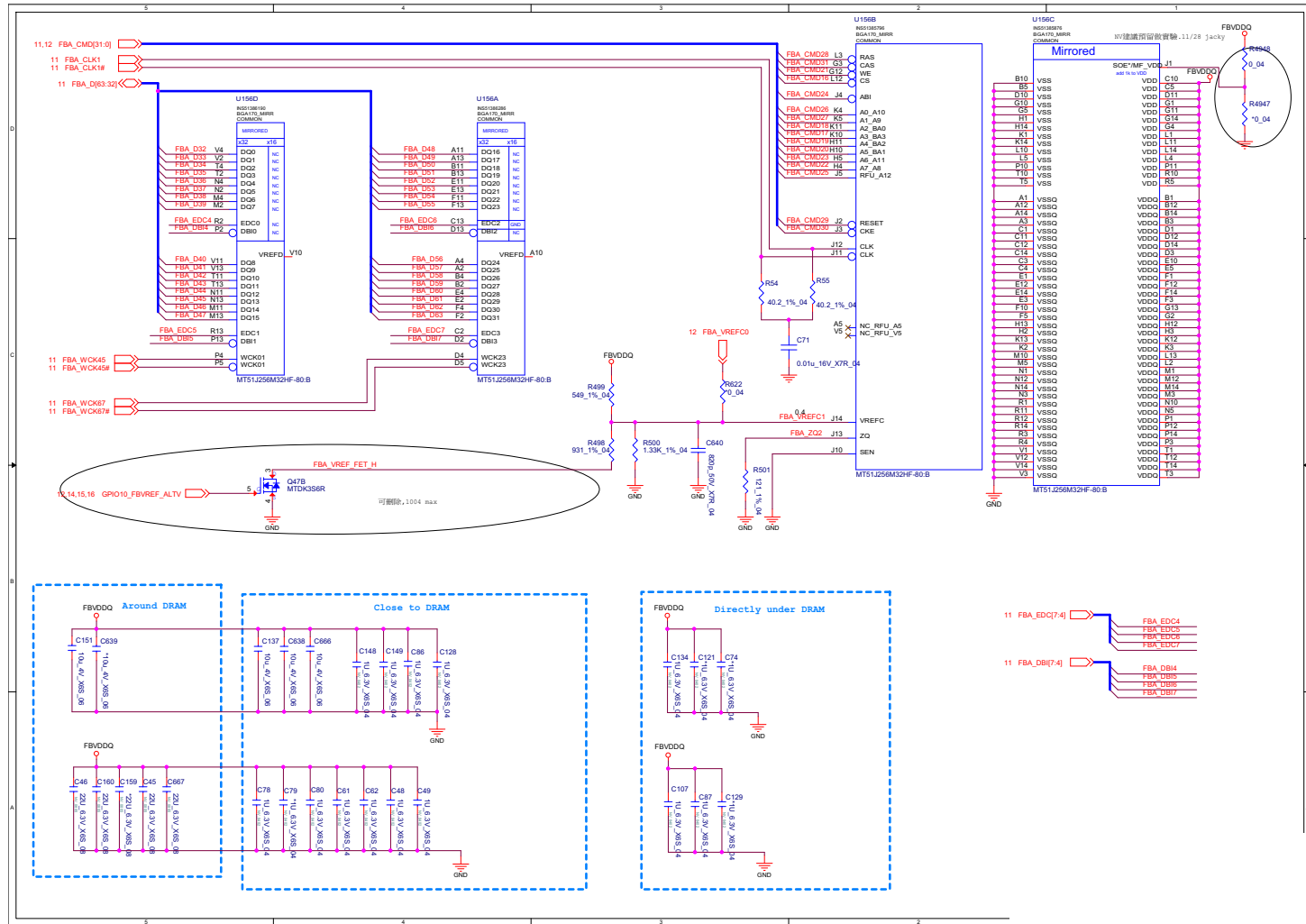

Sheet 13 of 64
Frame Buffer A

B.Schematic Diagrams

Frame Buffer B

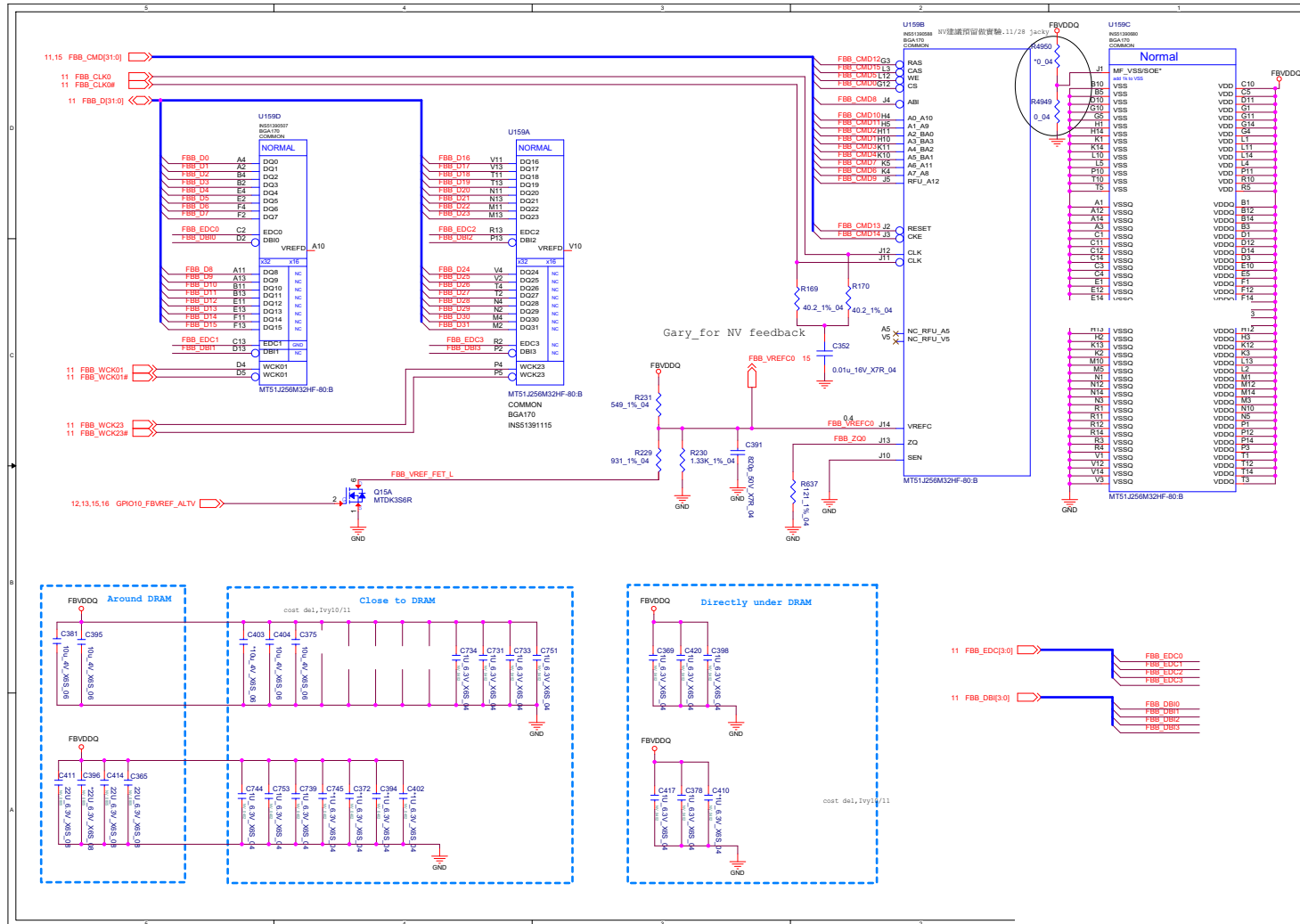

Sheet 14 of 64
Frame Buffer B

B.Schematic Diagrams

Frame Buffer B

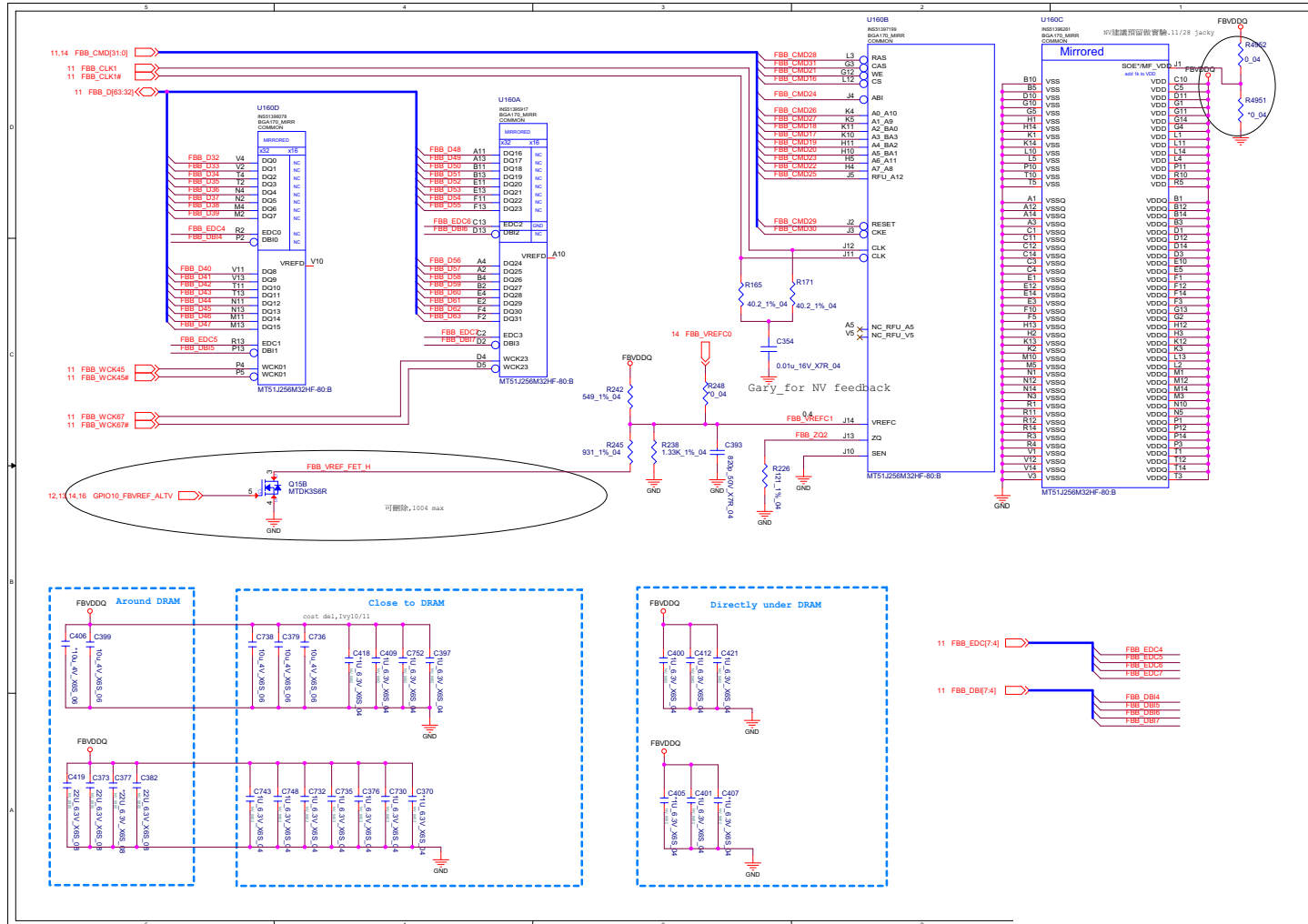

Sheet 15 of 64
Frame Buffer B

B.Schematic Diagrams

VGA I/O

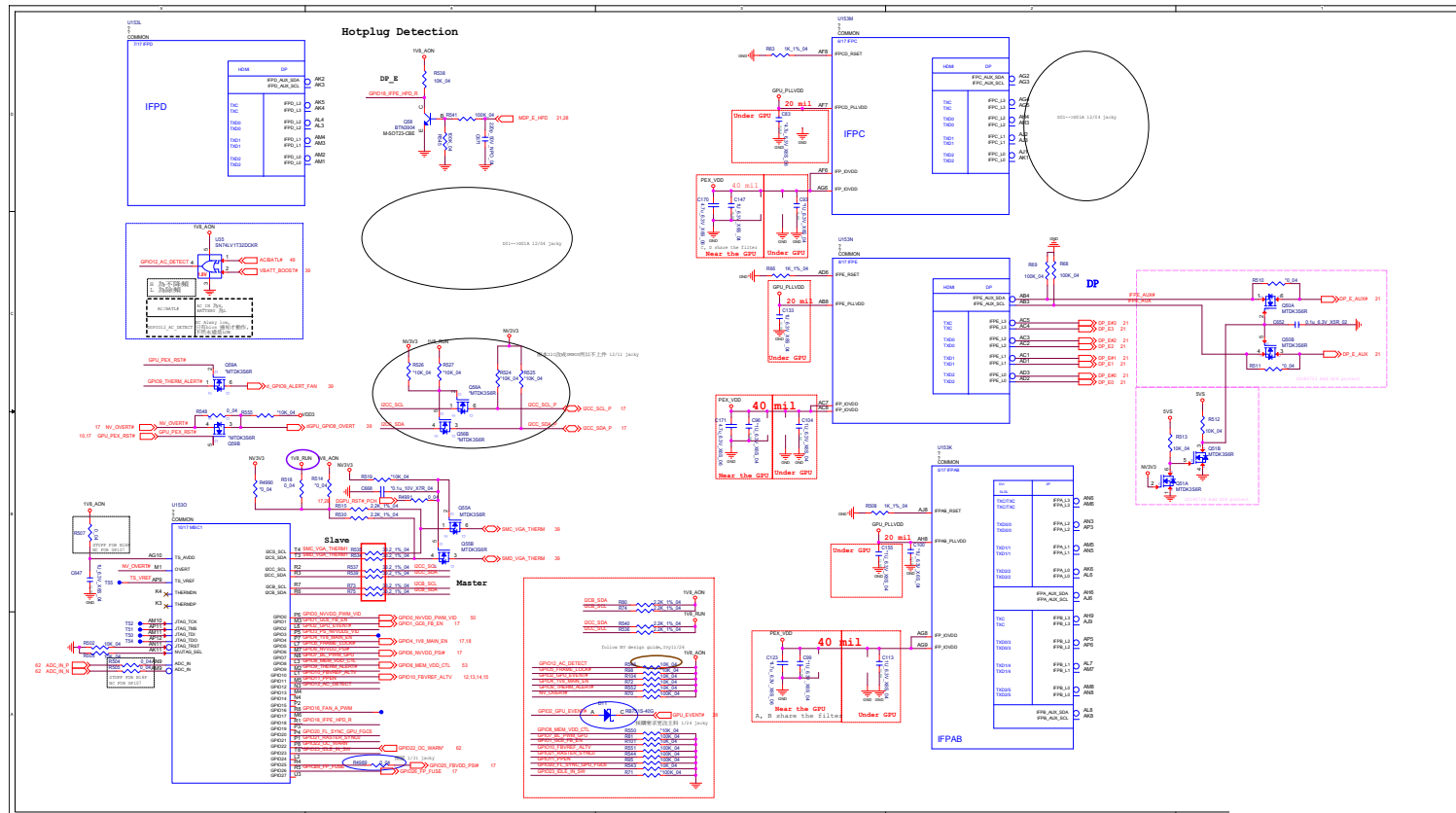

Sheet 16 of 64
VGA I/O

B.Schematic Diagrams

NVIDIA Power Sequence

Sheet 17 of 64
NVIDIA Power
Sequence

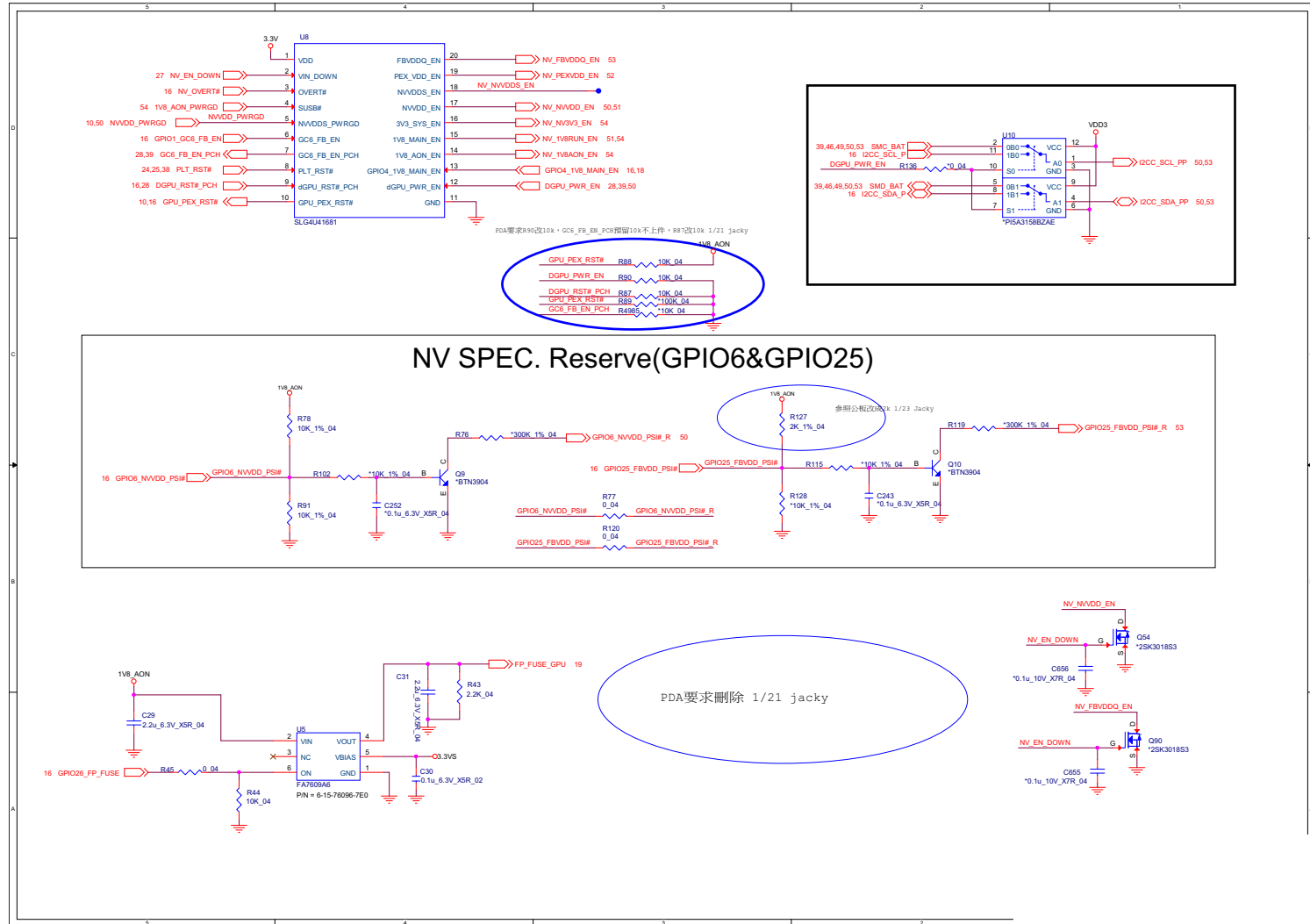

NVIDIA GPIO Level Shift

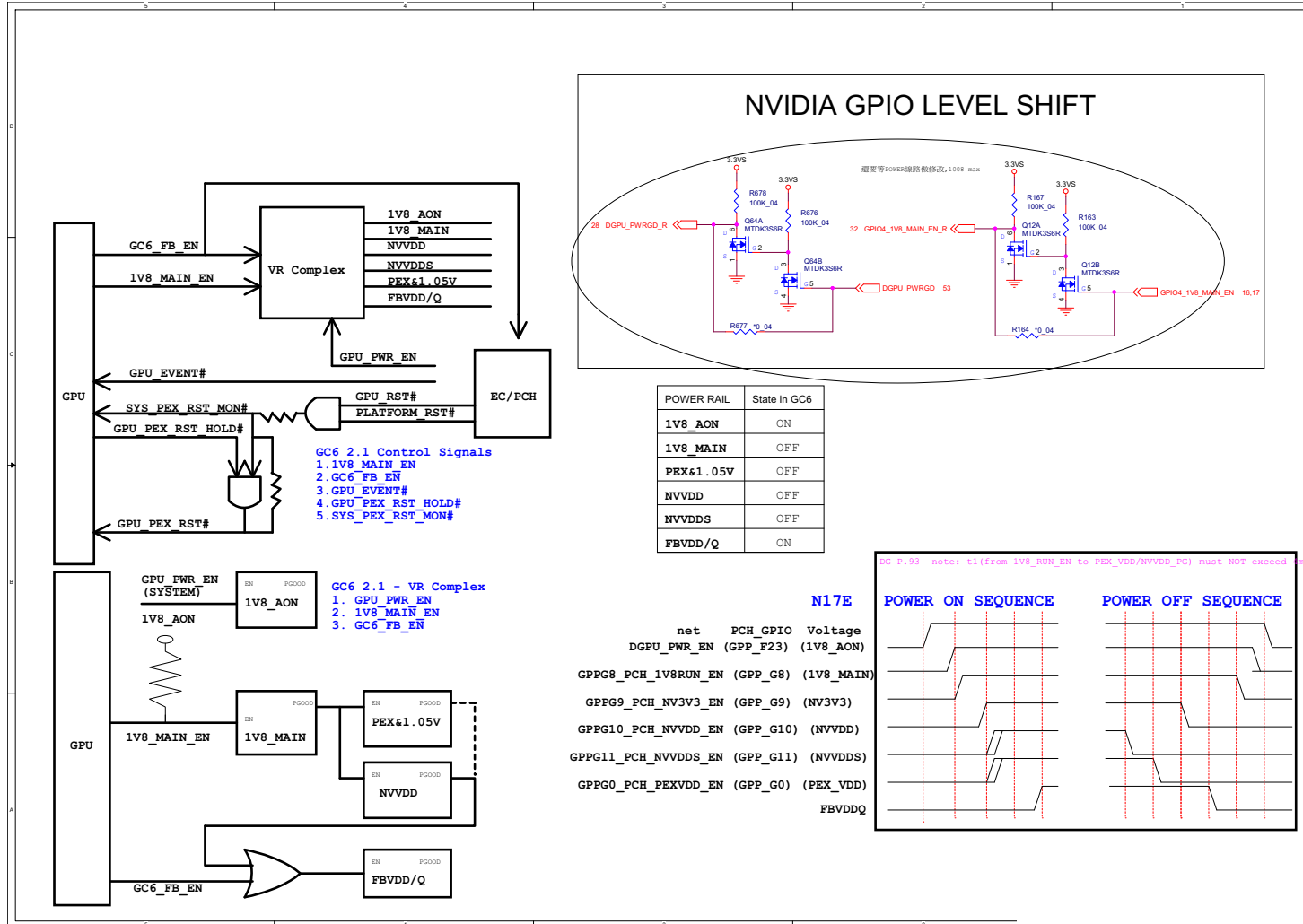

Sheet 18 of 64
NVIDIA GPIO Level Shift

VGA PWR / GND

Sheet 19 of 64
VGA PWR / GND

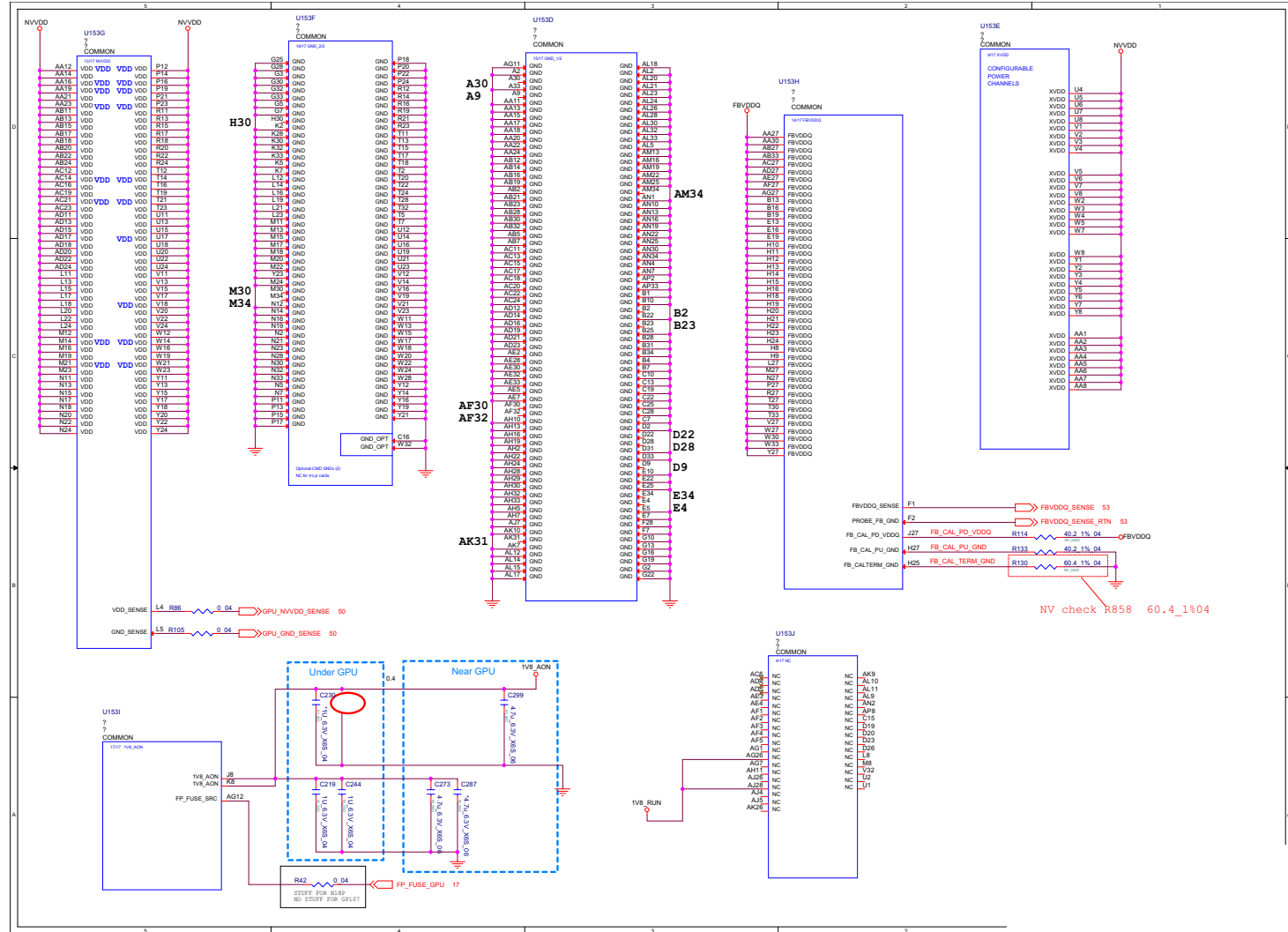

VGA NVVDD Coupling

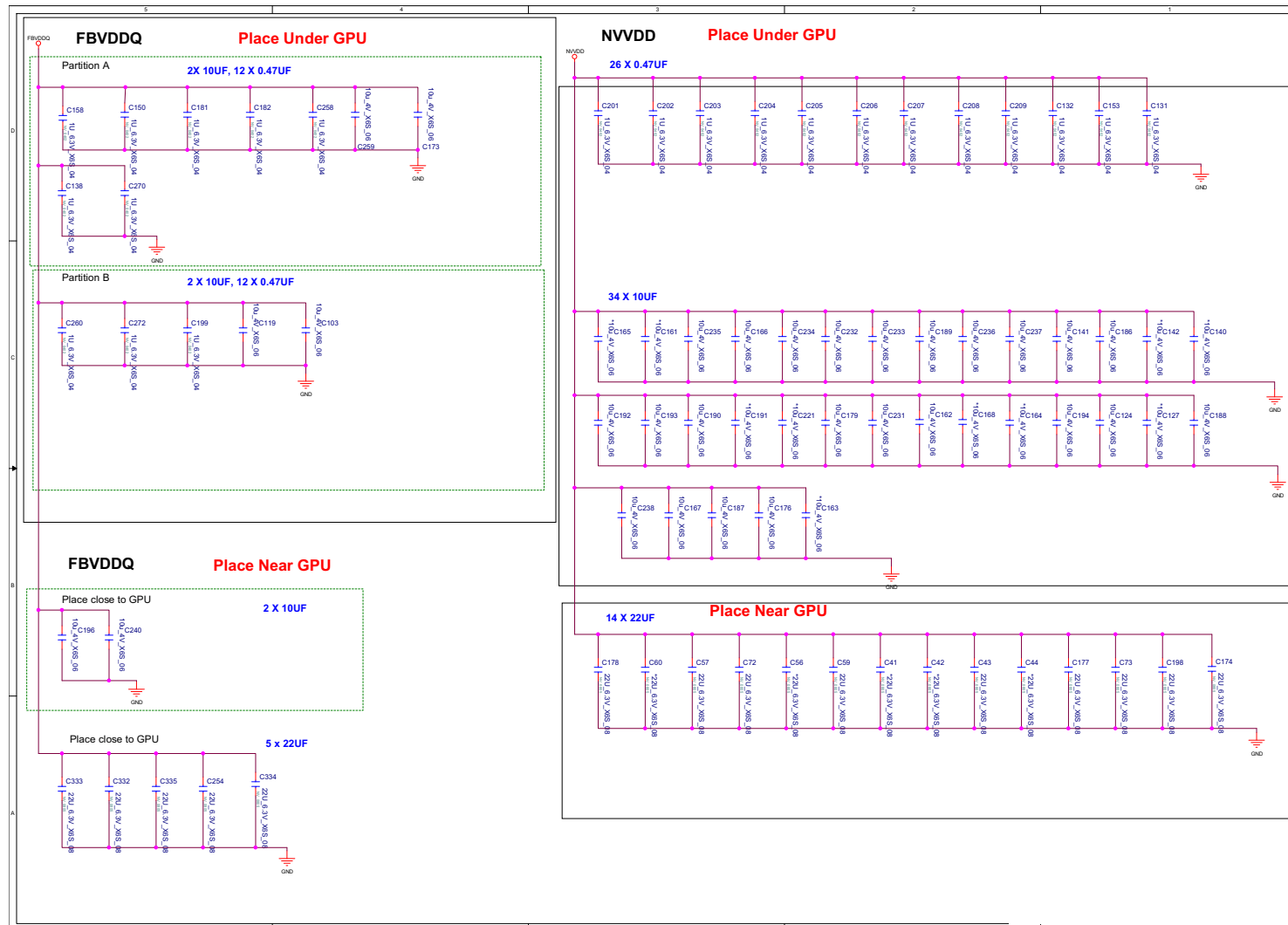

Sheet 20 of 64
VGA NVVDD
Coupling

Schematic Diagrams

MDP

B.Schematic Diagrams

Sheet 21 of 64
MDP

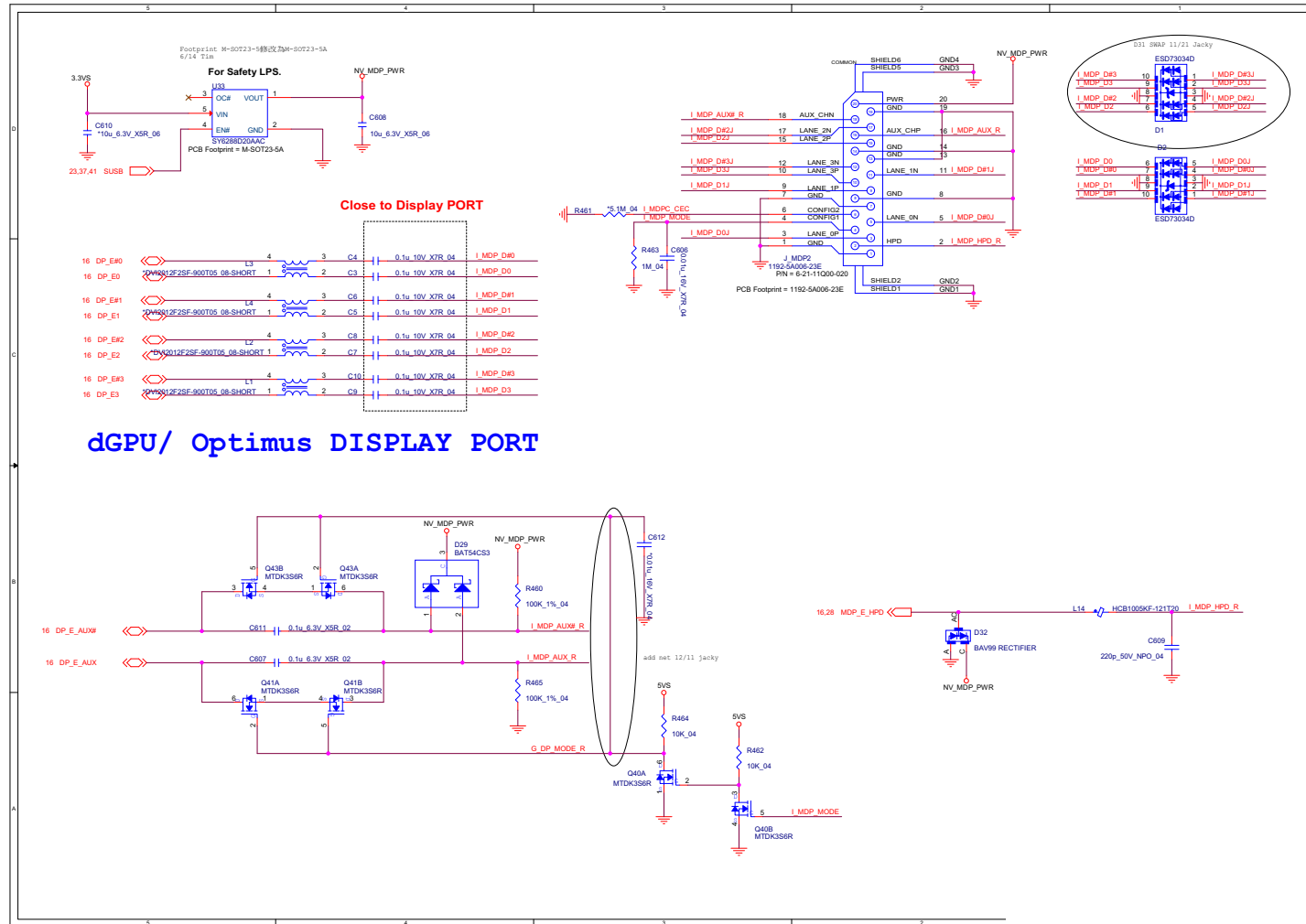

Panel, Inverter

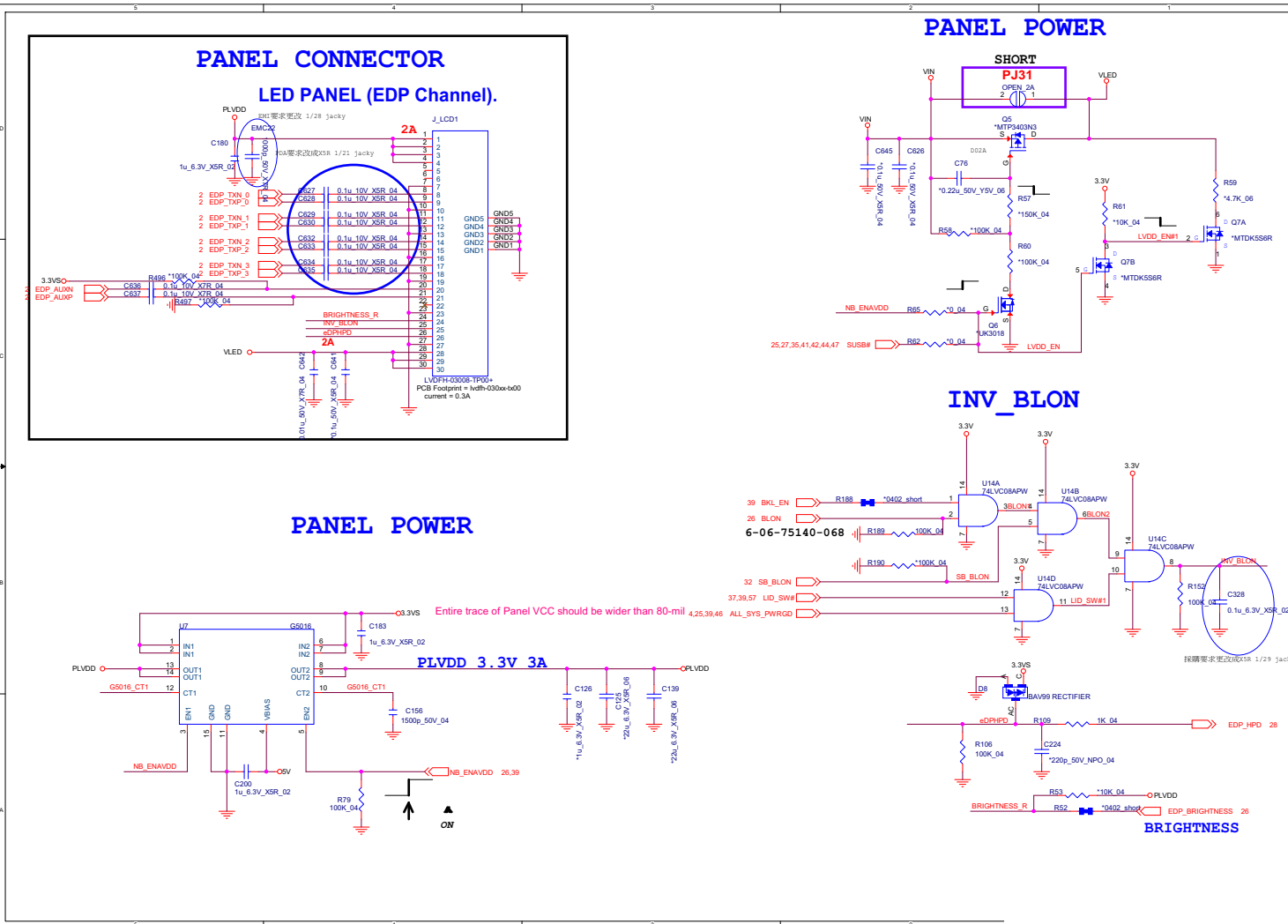

Sheet 22 of 64
Panel, Inverter

B.Schematic Diagrams

HDMI

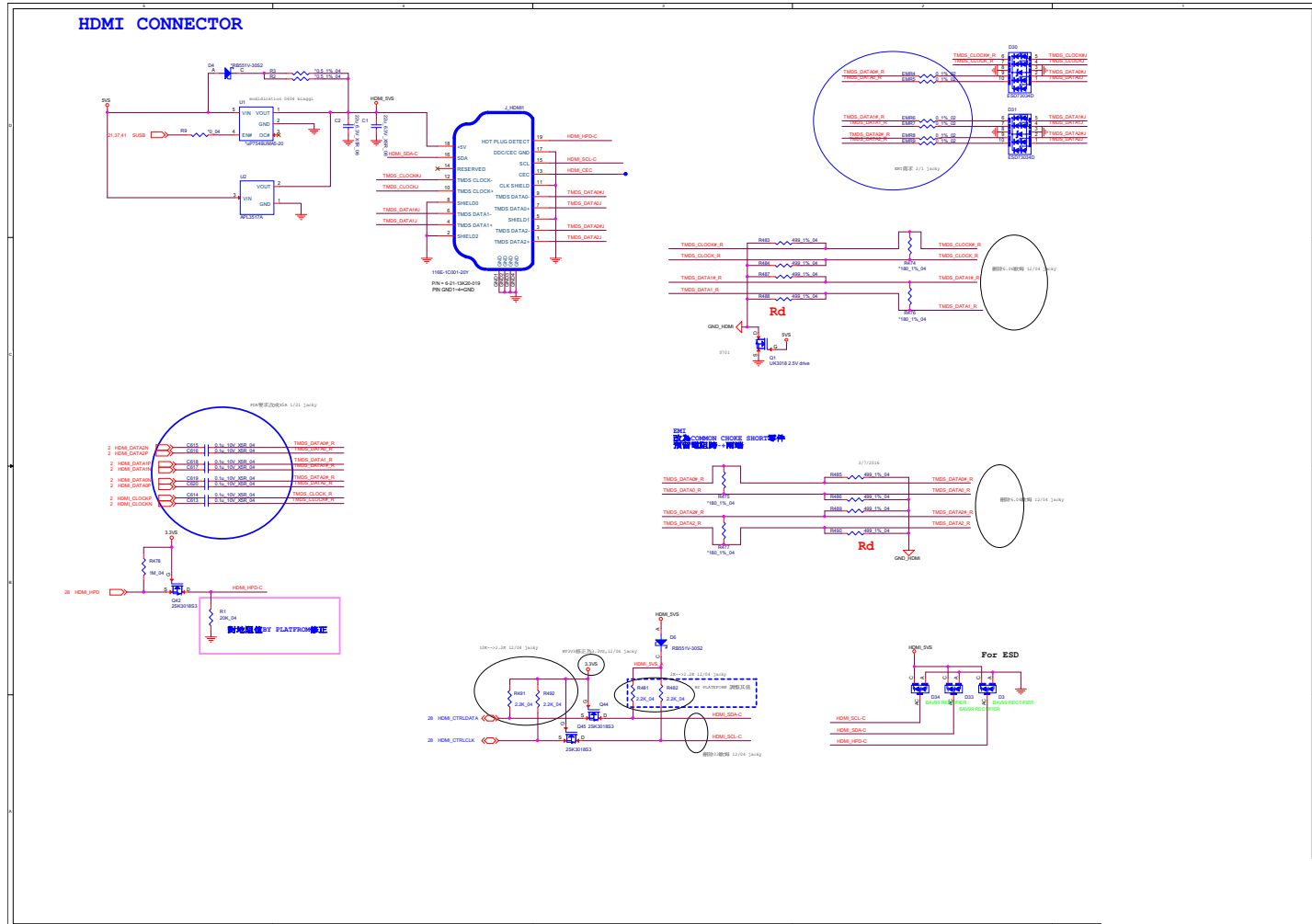

PCH 1/9

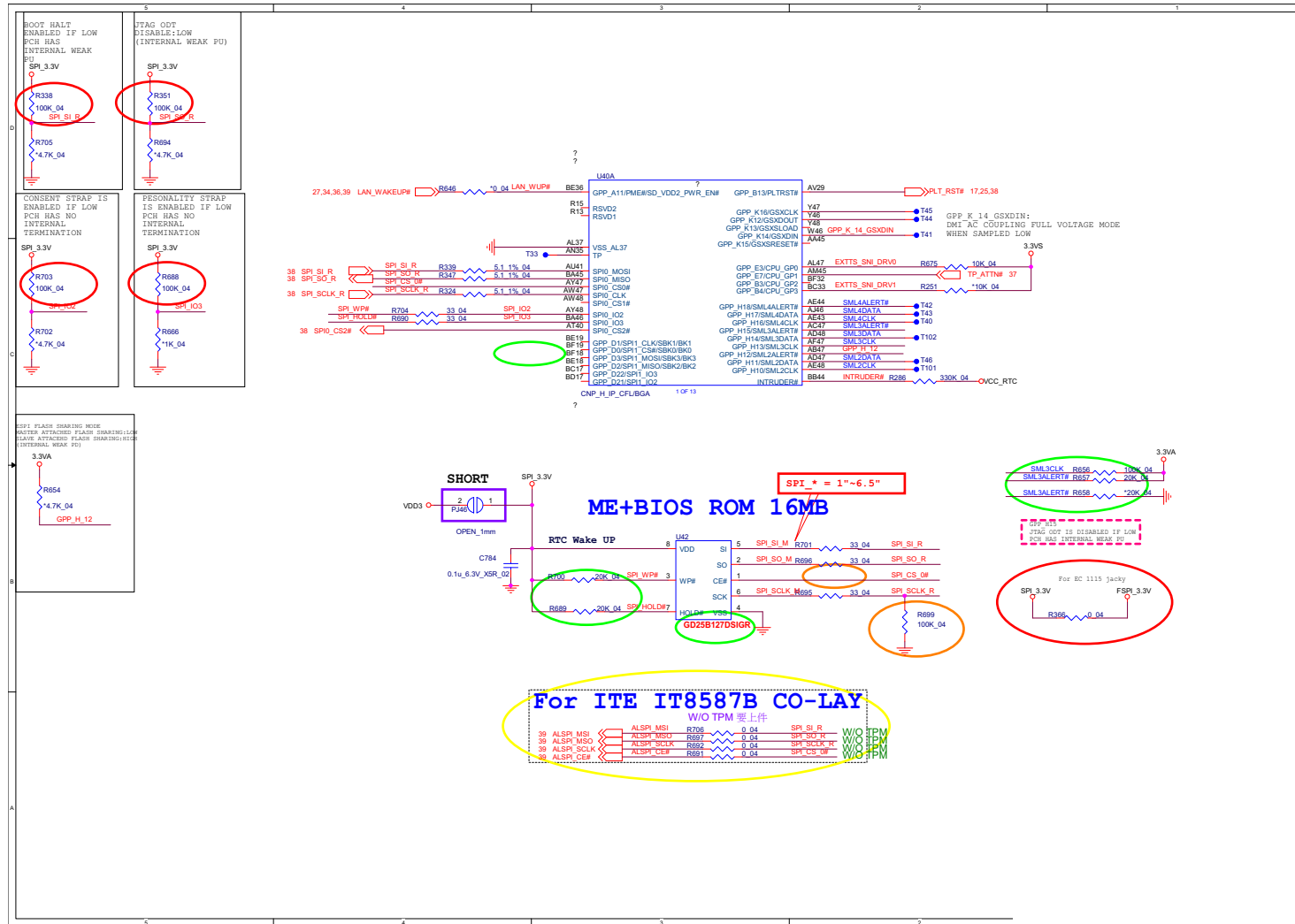

Sheet 24 of 64
PCH 1/9

PCH 2/9

B.Schematic Diagrams

Sheet 25 of 64
PCH 2/9

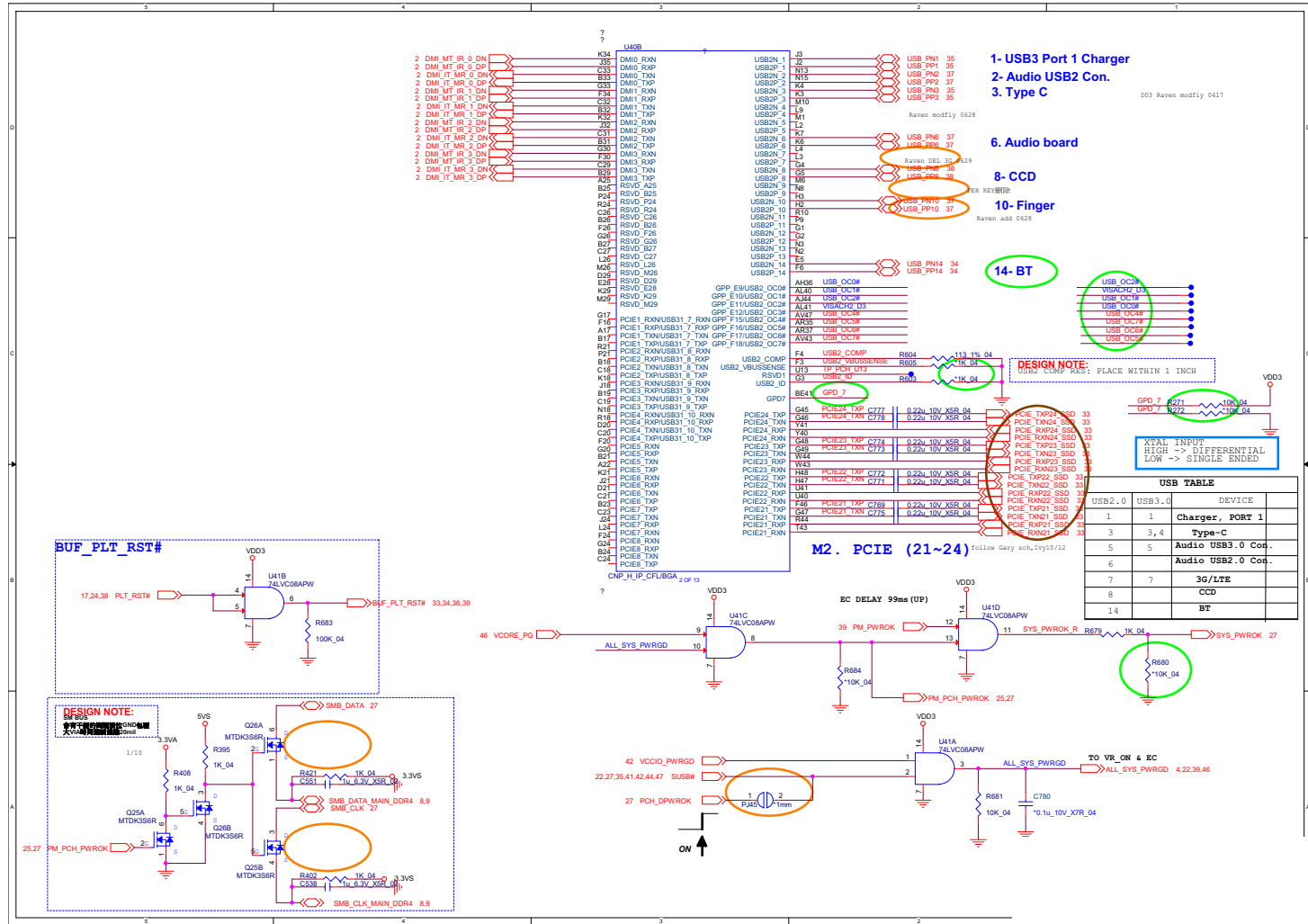

PCH 3/9

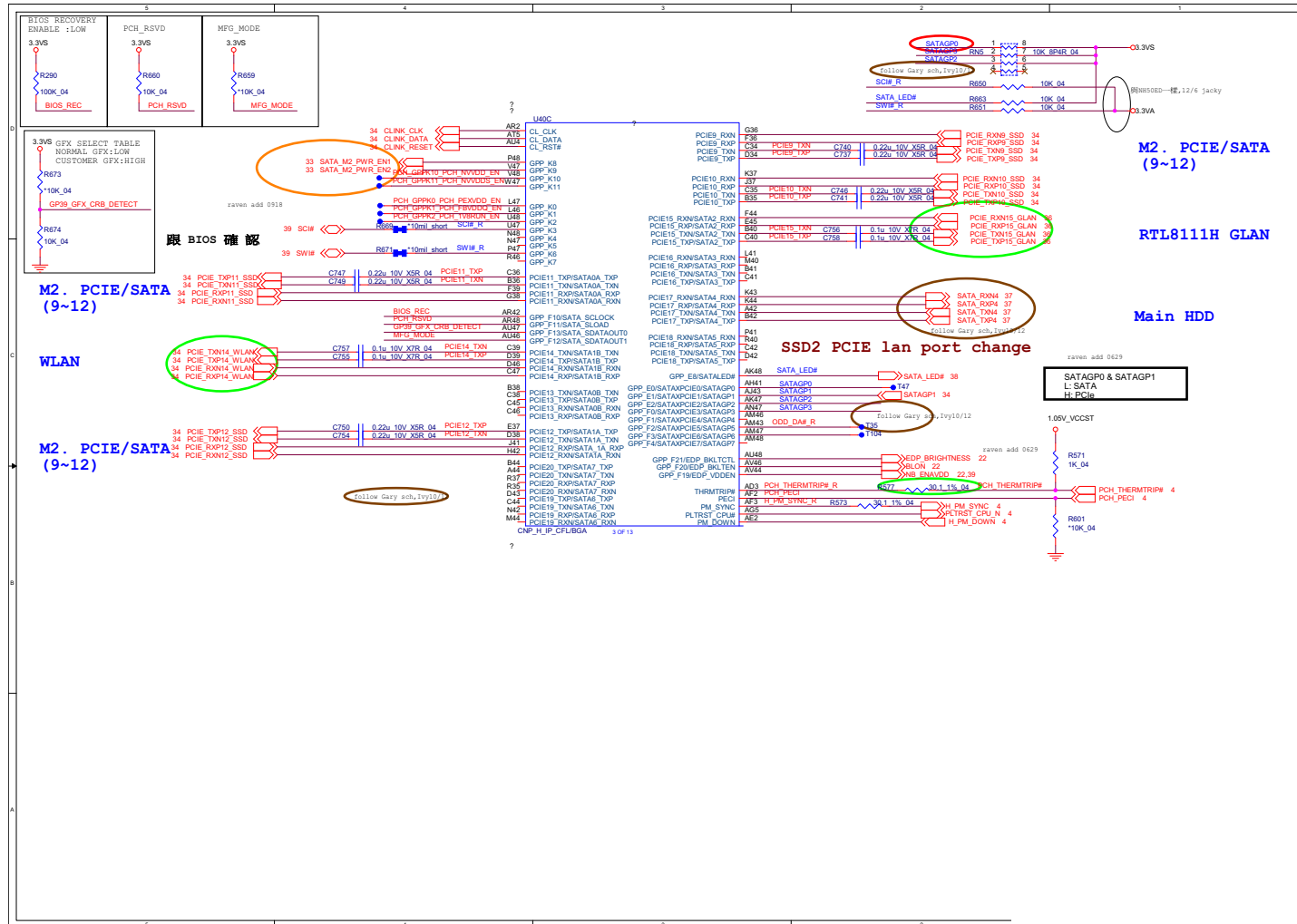

Sheet 26 of 64
PCH 3/9

B.Schematic Diagrams

PCH 5/9

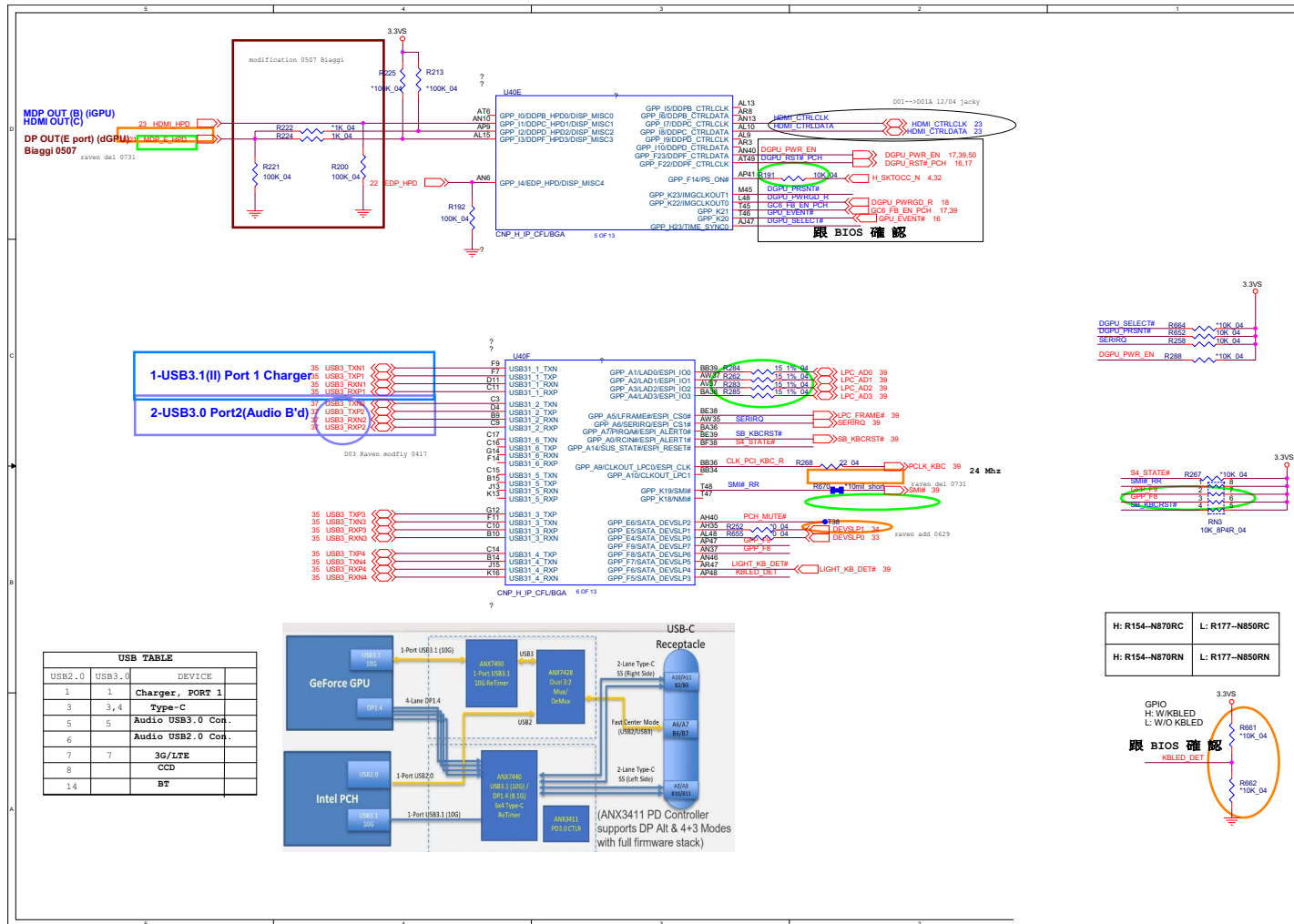

Sheet 28 of 64
PCH 5/9

USB TABLE		
USB2_0	USB3_0	DEVICE
1	1	Charger, PORT 1
3	3, 4	Type-C
5	5	Audio USB3.0 Cont.
6		Audio USB2.0 Cont.
7	7	3G/LITE
8		CCD
14		BT

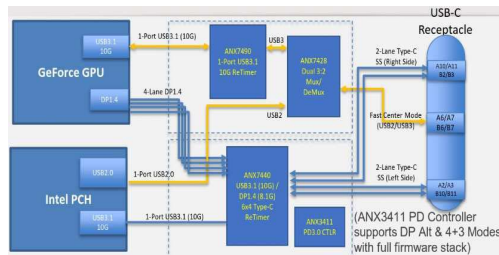

H: R154~N870RC	L: R177~N850RC
H: R154~N870RN	L: R177~N850RN

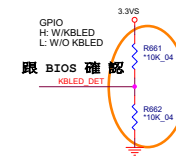

Schematic Diagrams

PCH 6/9

Sheet 29 of 64
PCH 6/9

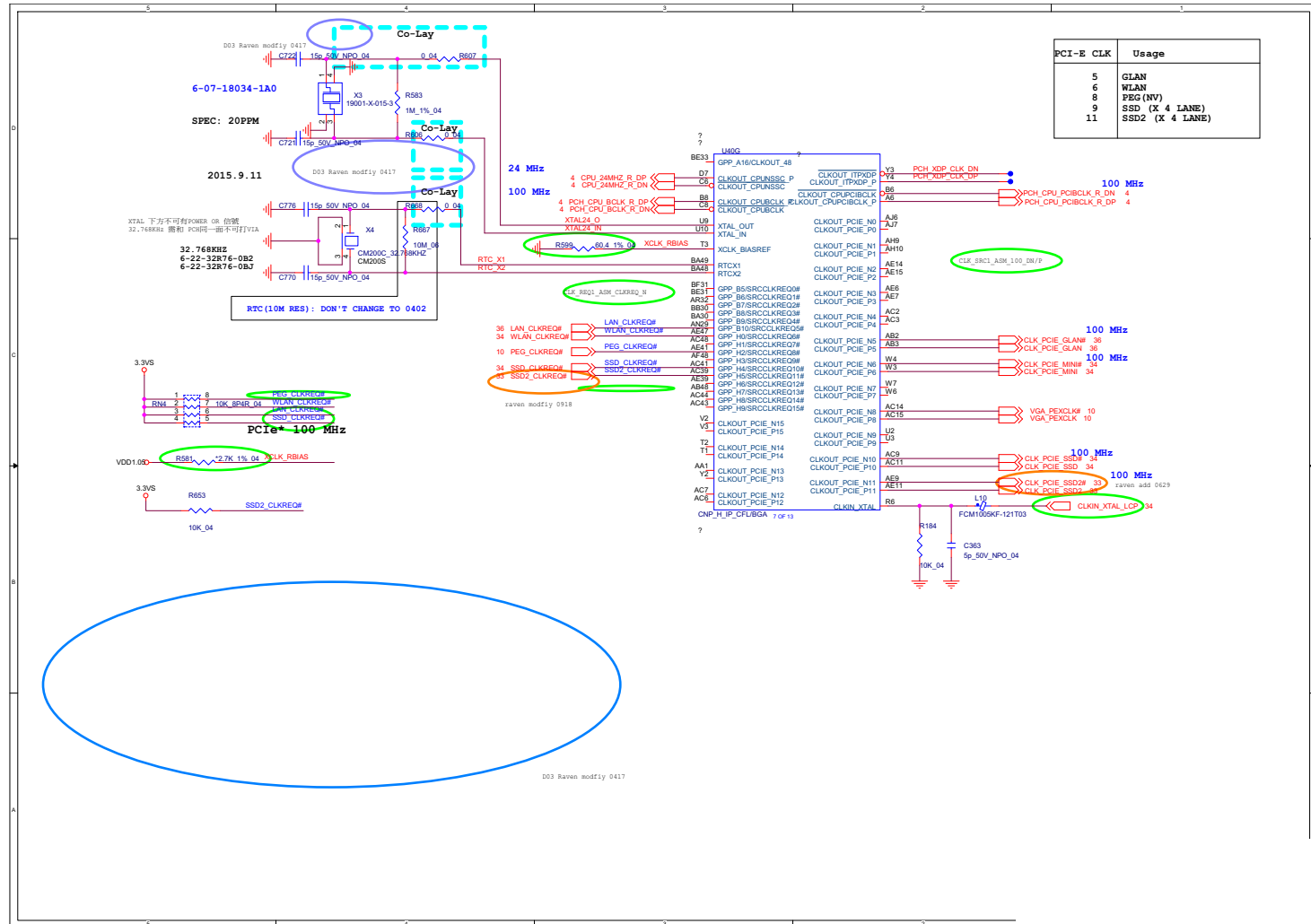

PCH 8/9

Sheet 31 of 64
PCH 8/9

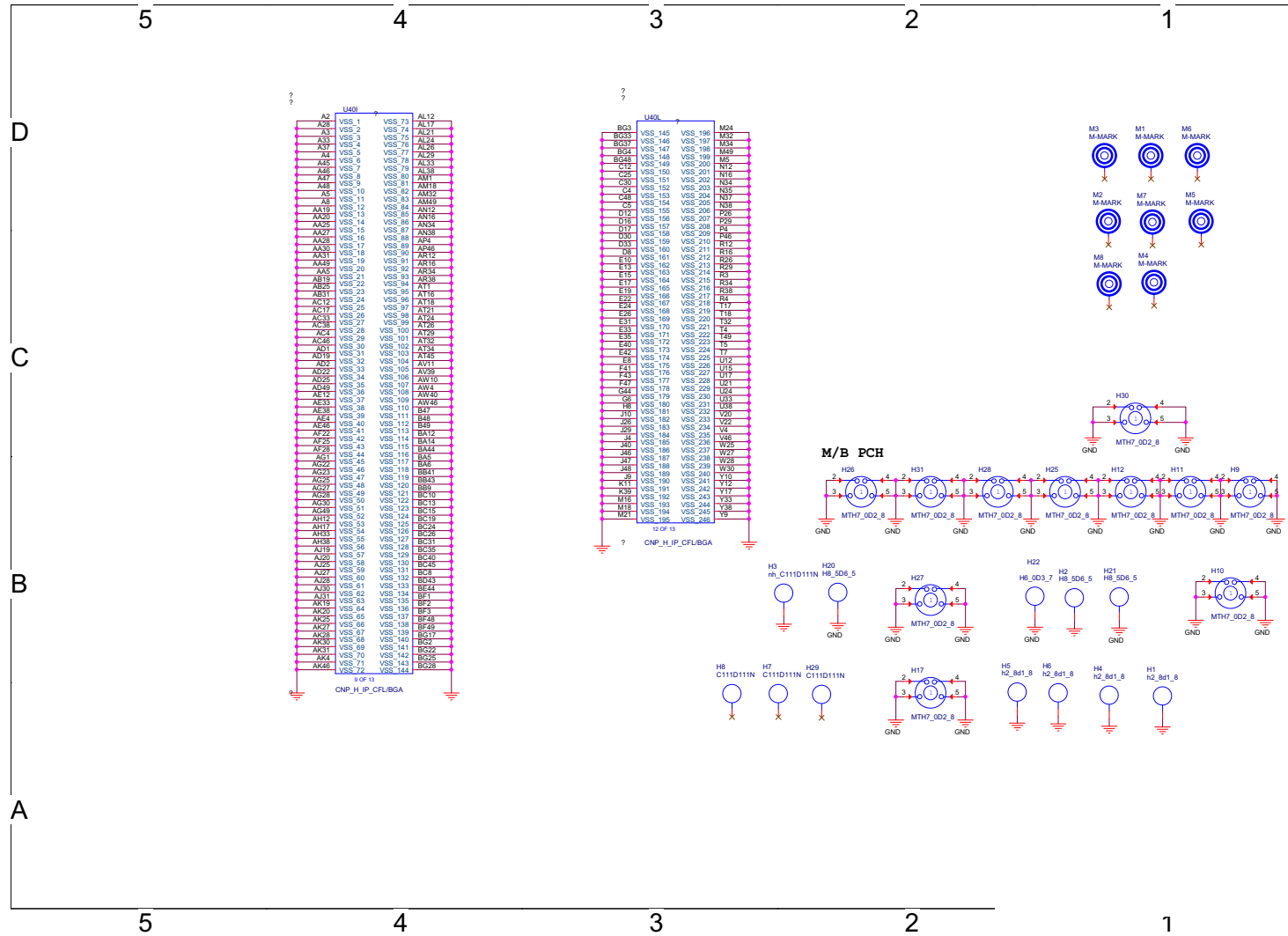

M.2 Card

Sheet 33 of 64
M.2 Card

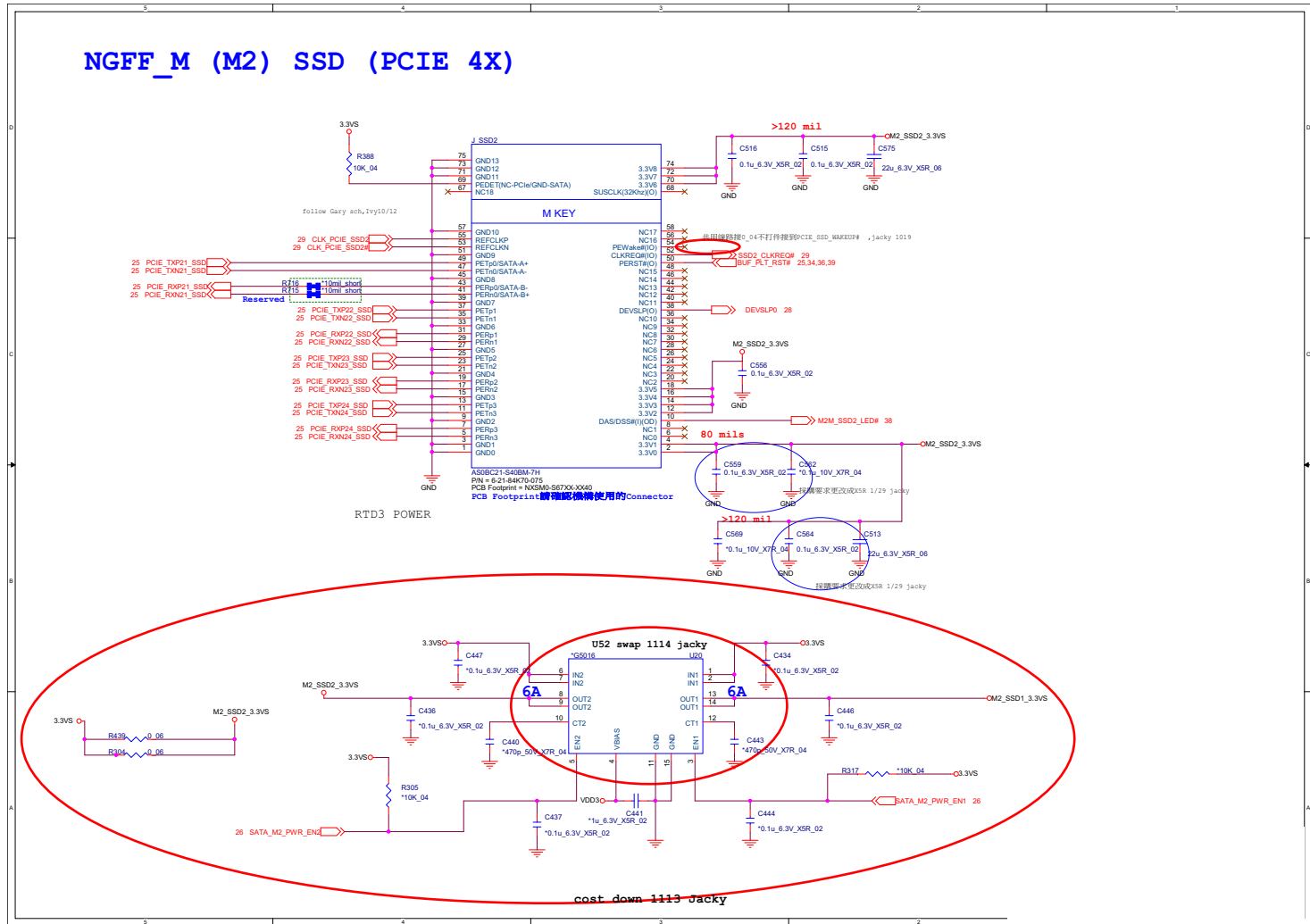

M.2 WLAN+BT

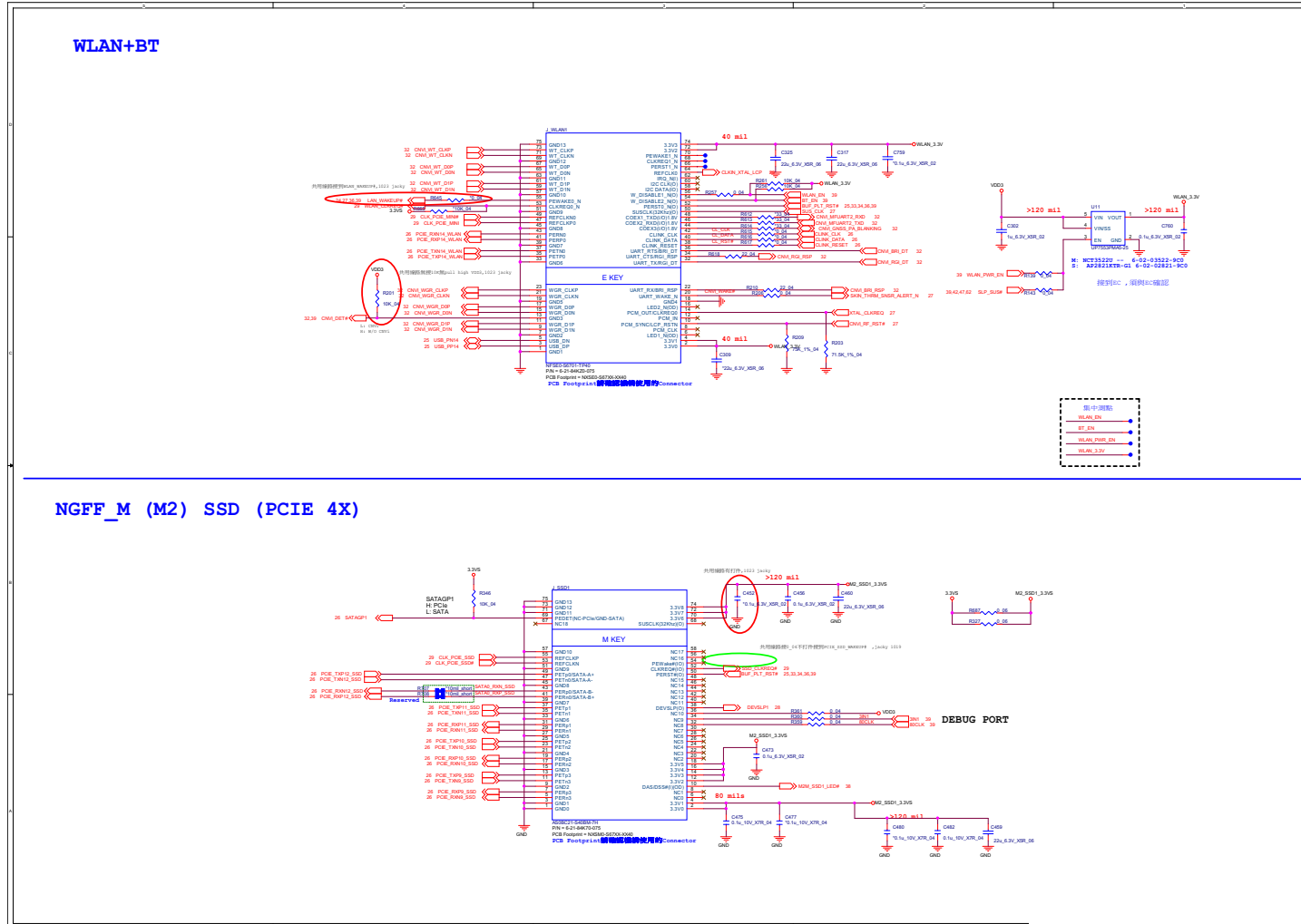

Sheet 34 of 64
M.2 WLAN+BT

B.Schematic Diagrams

USB Charger

Sheet 35 of 64
USB Charger

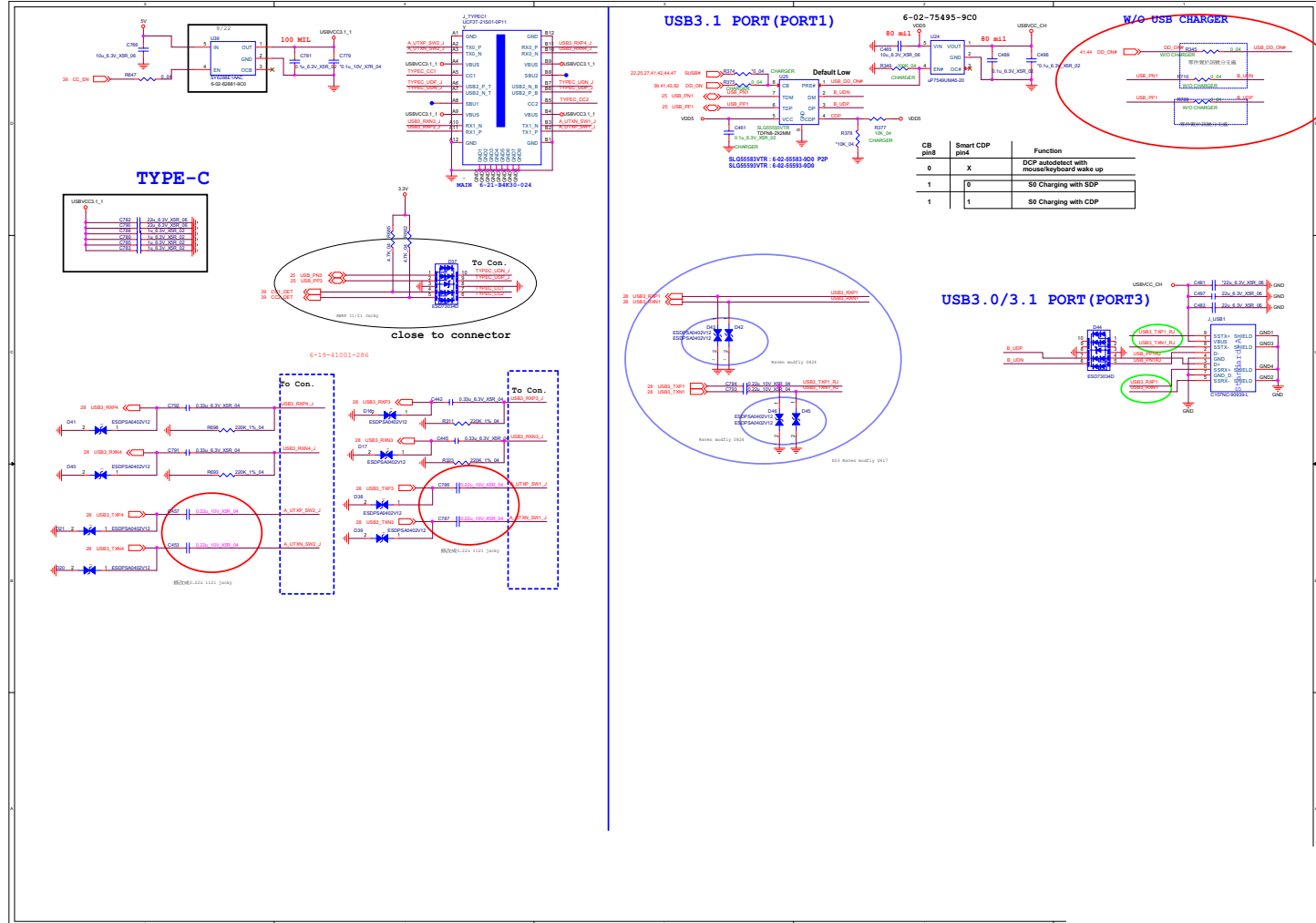

Card Reader / LAN RTL8411B

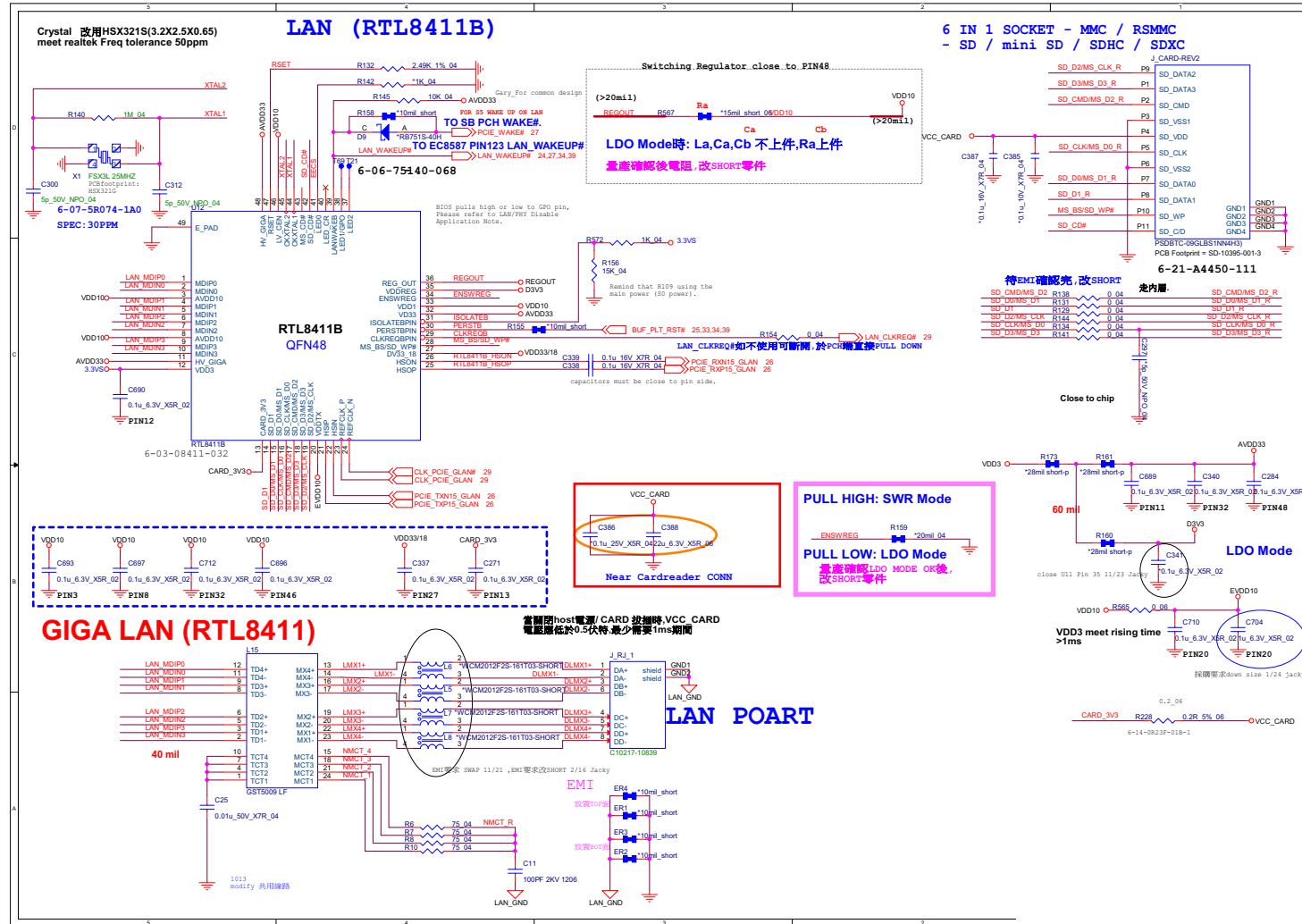

Sheet 36 of 64
Card Reader /
LAN RTL8411B

B.Schematic Diagrams

HDD, Click TP, Audio, Hall Con.

Sheet 37 of 64
HDD, Click TP,
Audio, Hall Con.

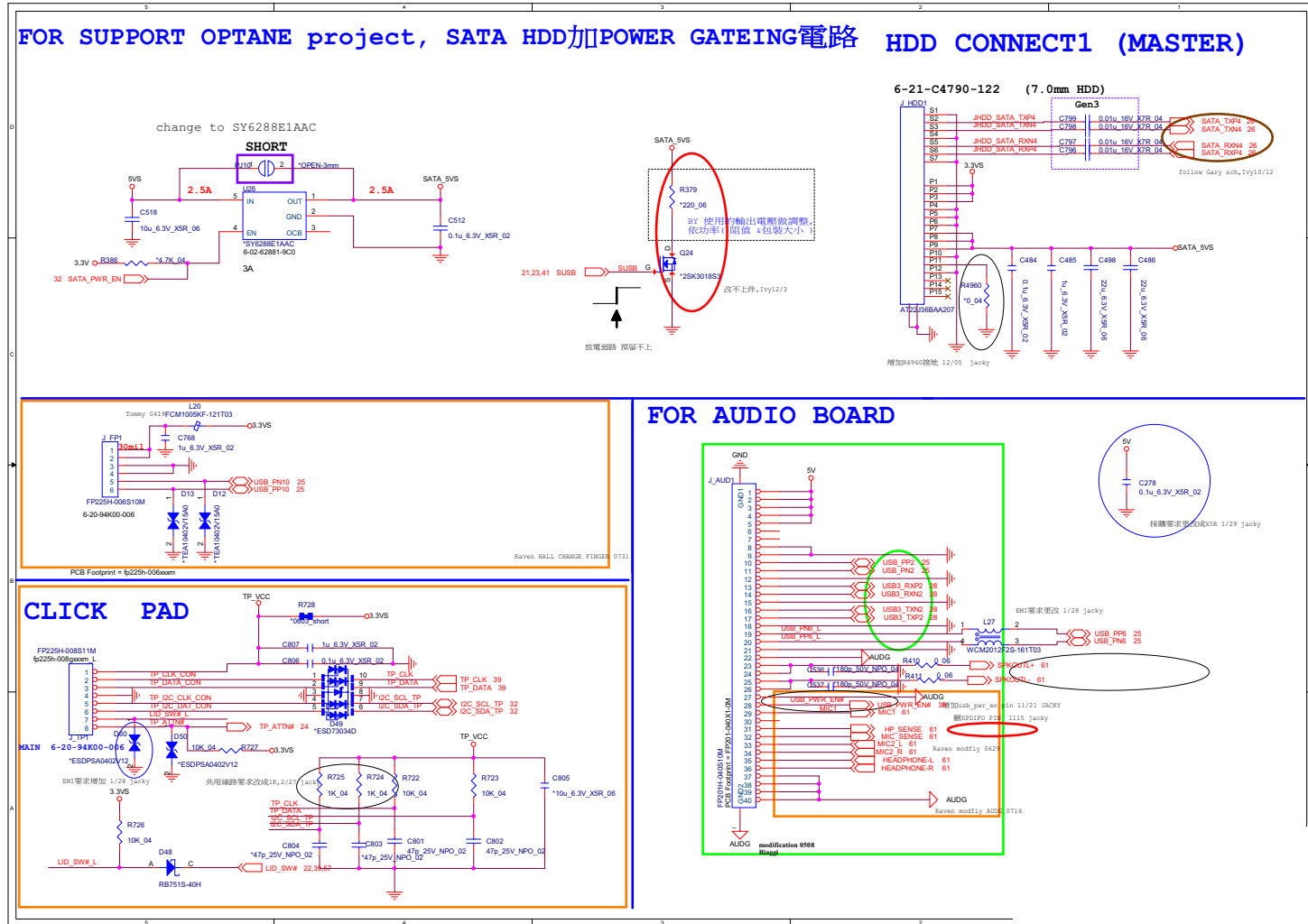

LED, CCD, TPM, Power SW Con.

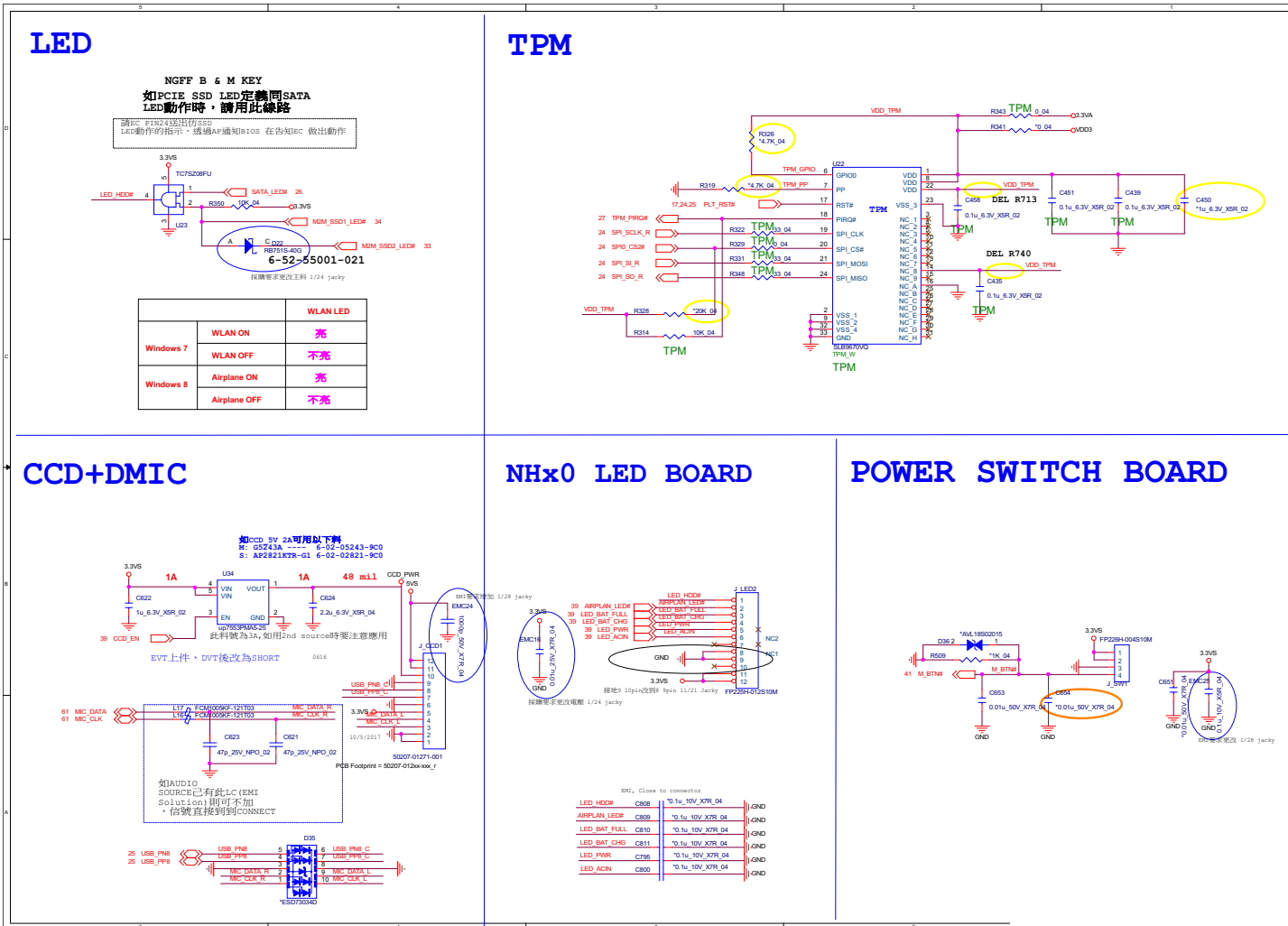

Sheet 38 of 64
LED, CCD, TPM,
Power SW Con.

B.Schematic Diagrams

RGB KB Only

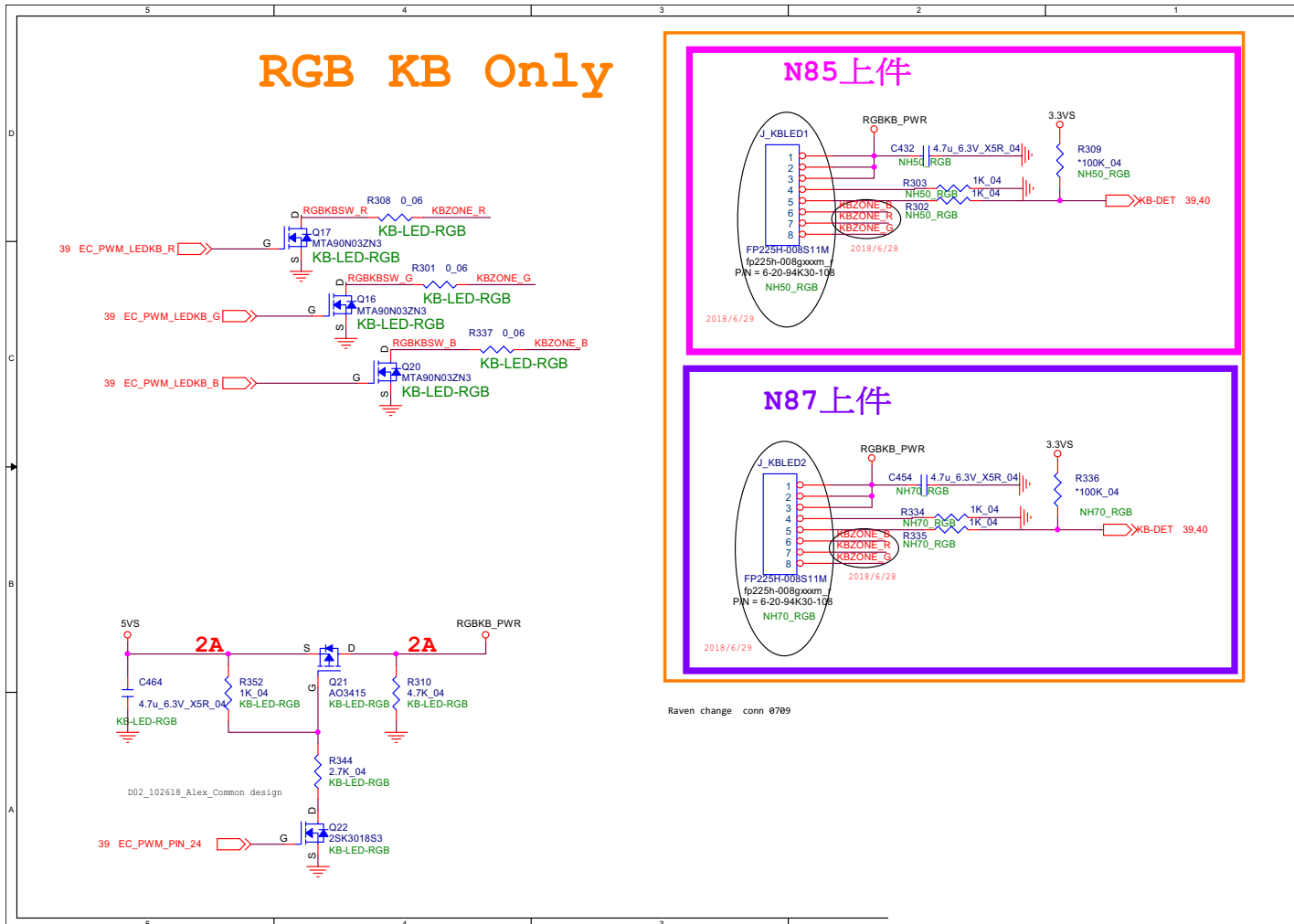

Sheet 40 of 64
RGB KB Only

B.Schematic Diagrams

Schematic Diagrams

5V, 5VS, 3.3V, 3.3VS

B.Schematic Diagrams

Sheet 41 of 64
5V, 5VS, 3.3V,
3.3VS

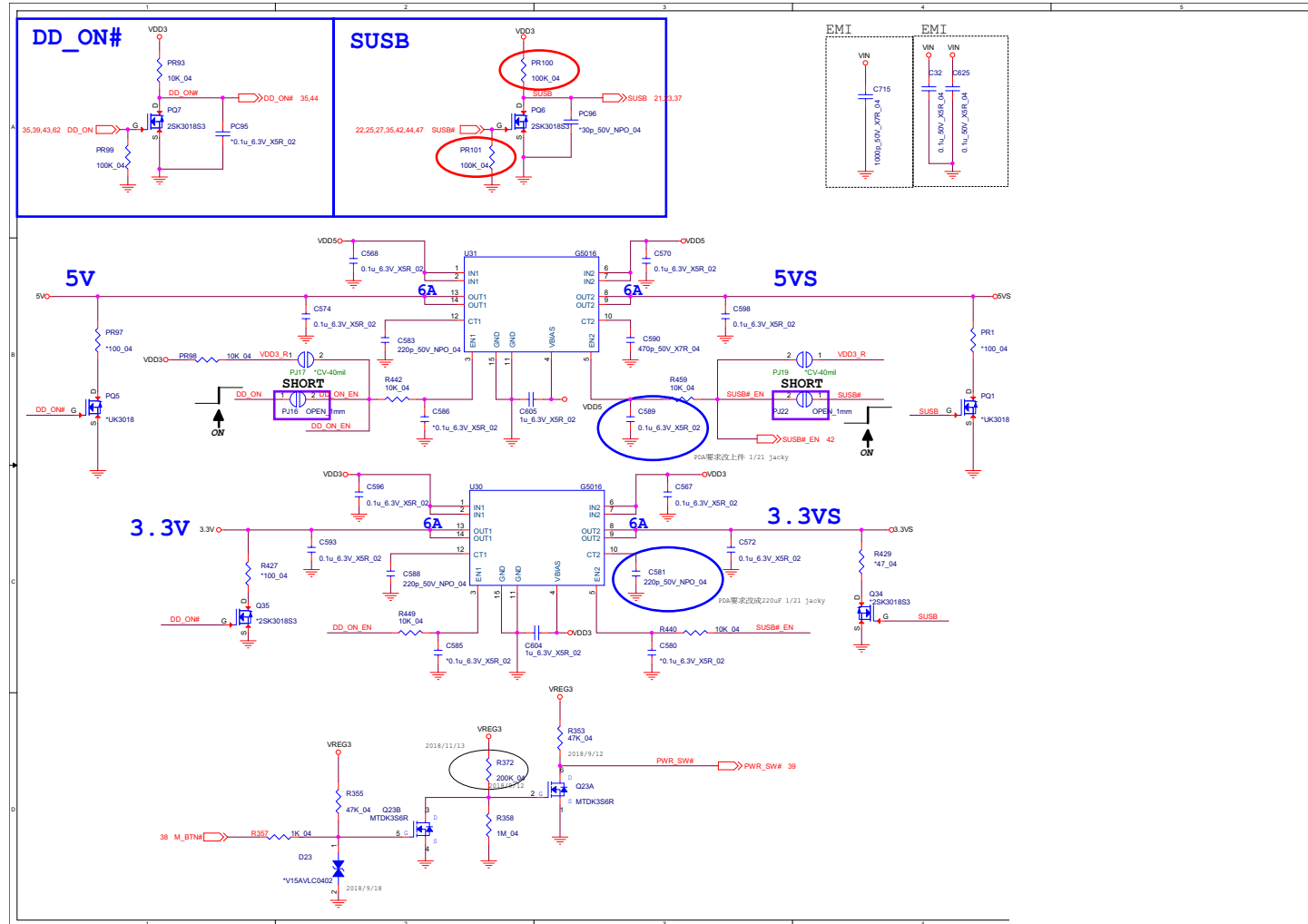

VDD1.05V, VCCIO

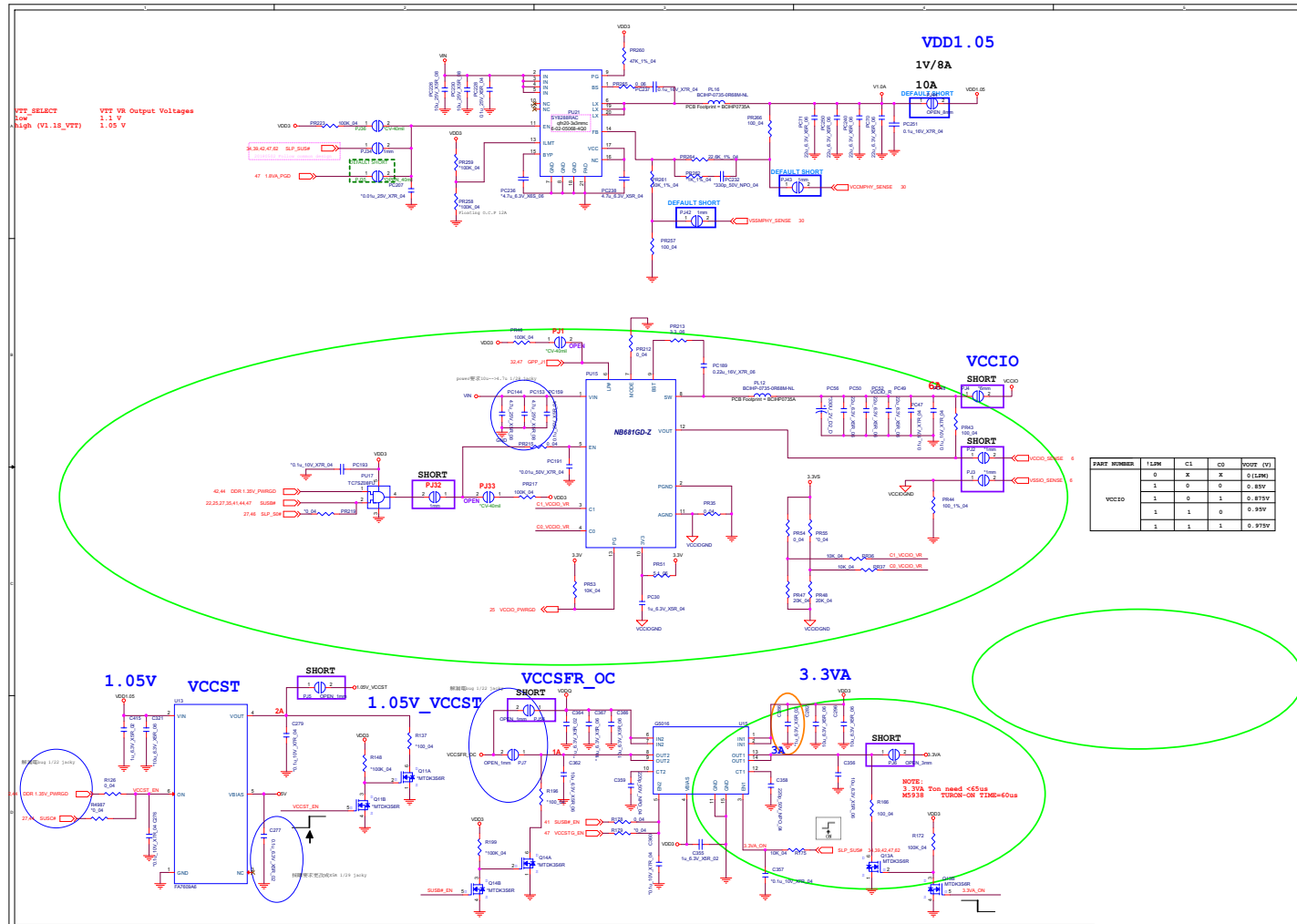

Sheet 42 of 64
VDD1.05V, VCCIO

DDR 1.2V / 0.6VS, 2.5V

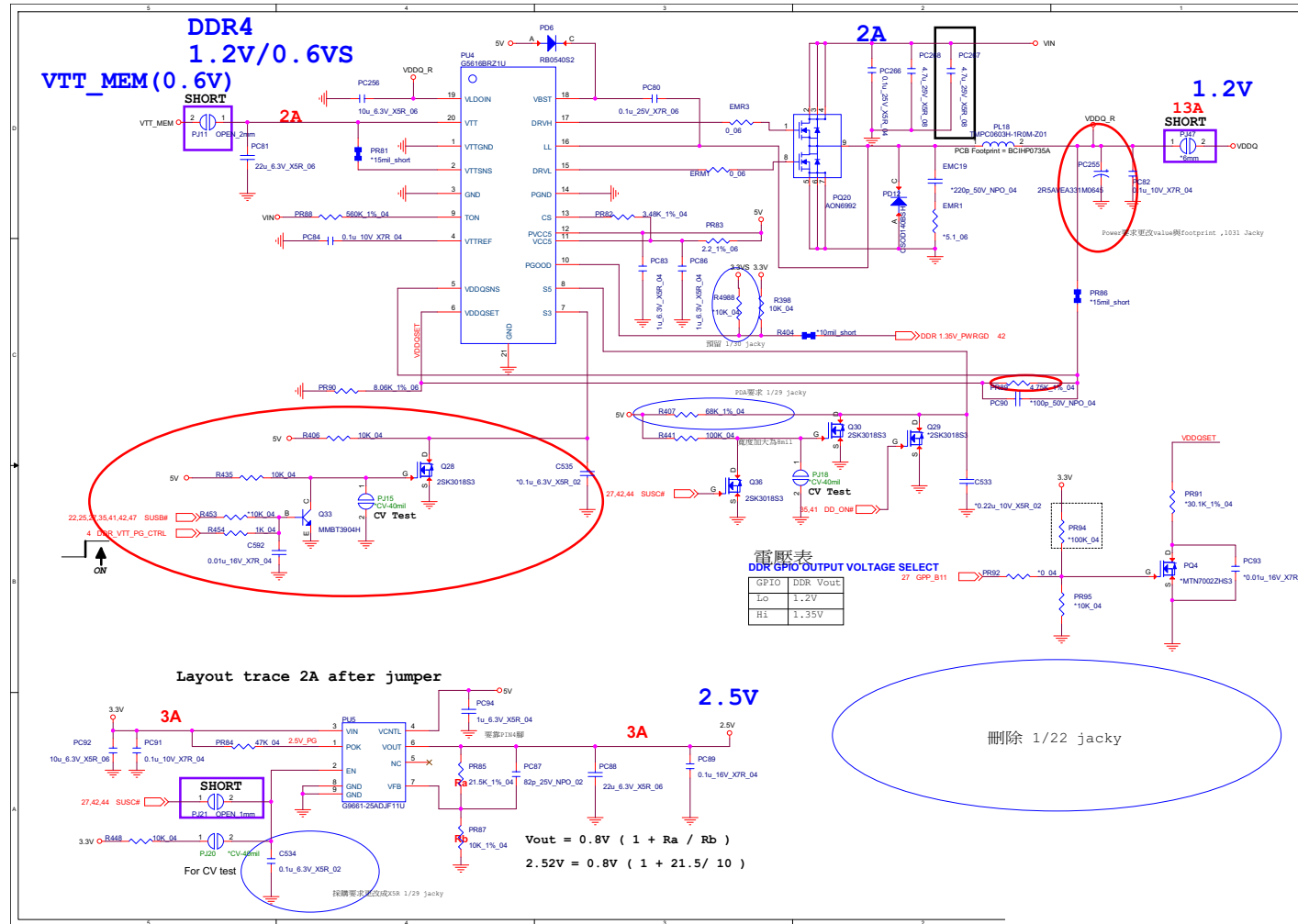

Sheet 44 of 64
DDR 1.2V / 0.6VS,
2.5V

VCC_Core & VCCGT

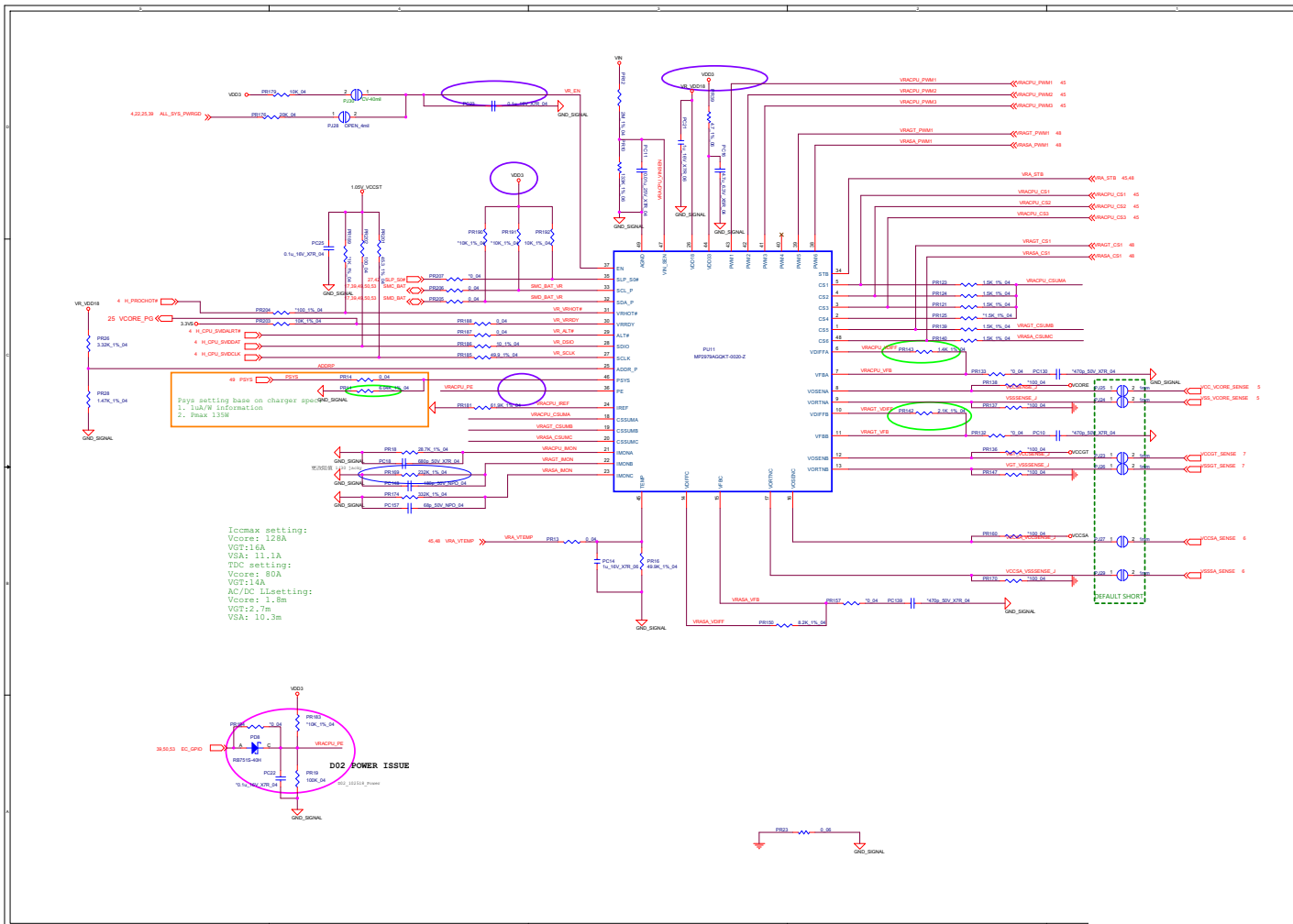

Sheet 46 of 64
**VCC_Core &
 VCCGT**

B.Schematic Diagrams

VCCGT & VCCSA Output Stage

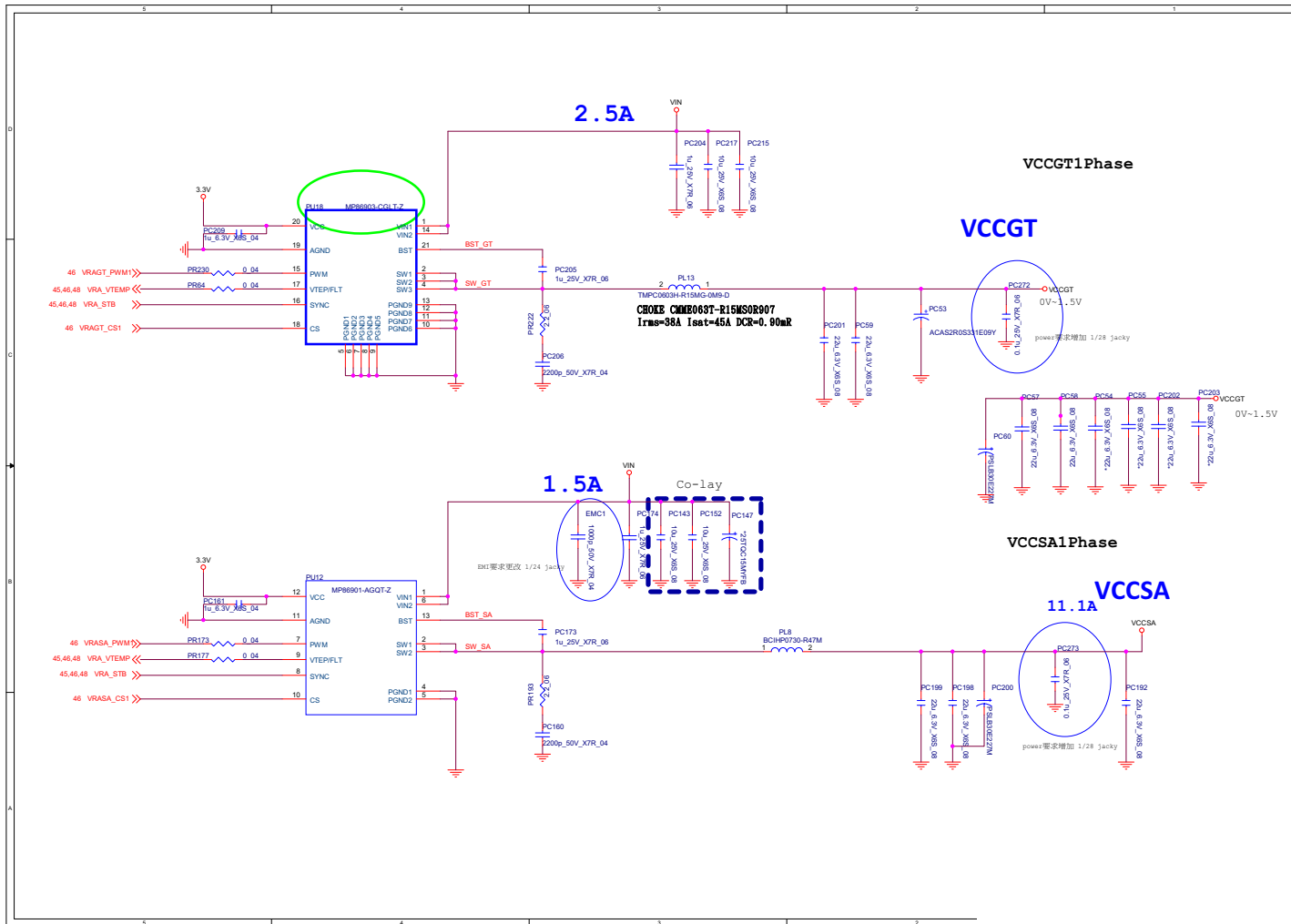

Sheet 48 of 64
VCCGT & VCCSA
Output Stage

B.Schematic Diagrams

AC_In, Charger

Sheet 49 of 64
AC_In, Charger

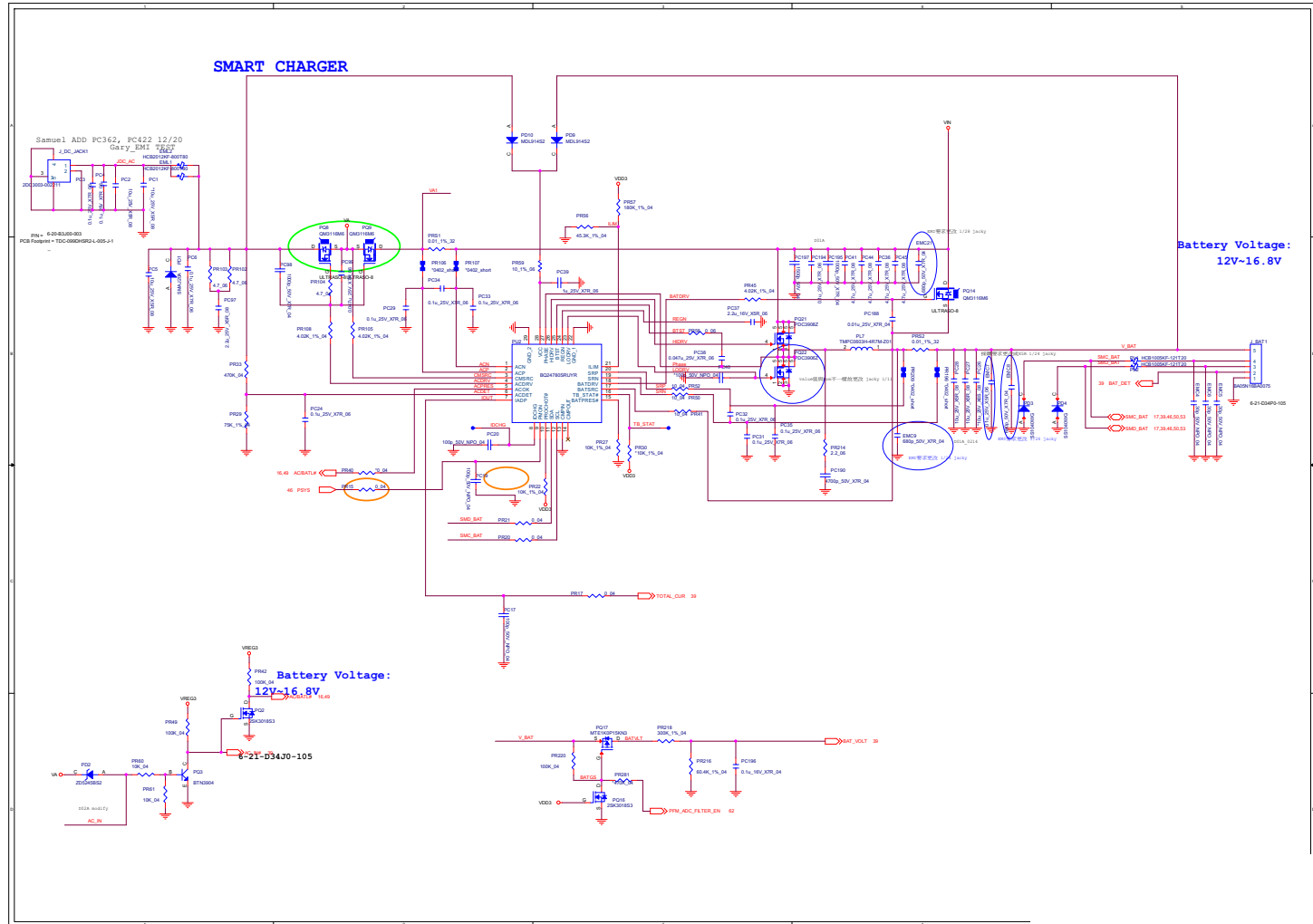

NVVDD1

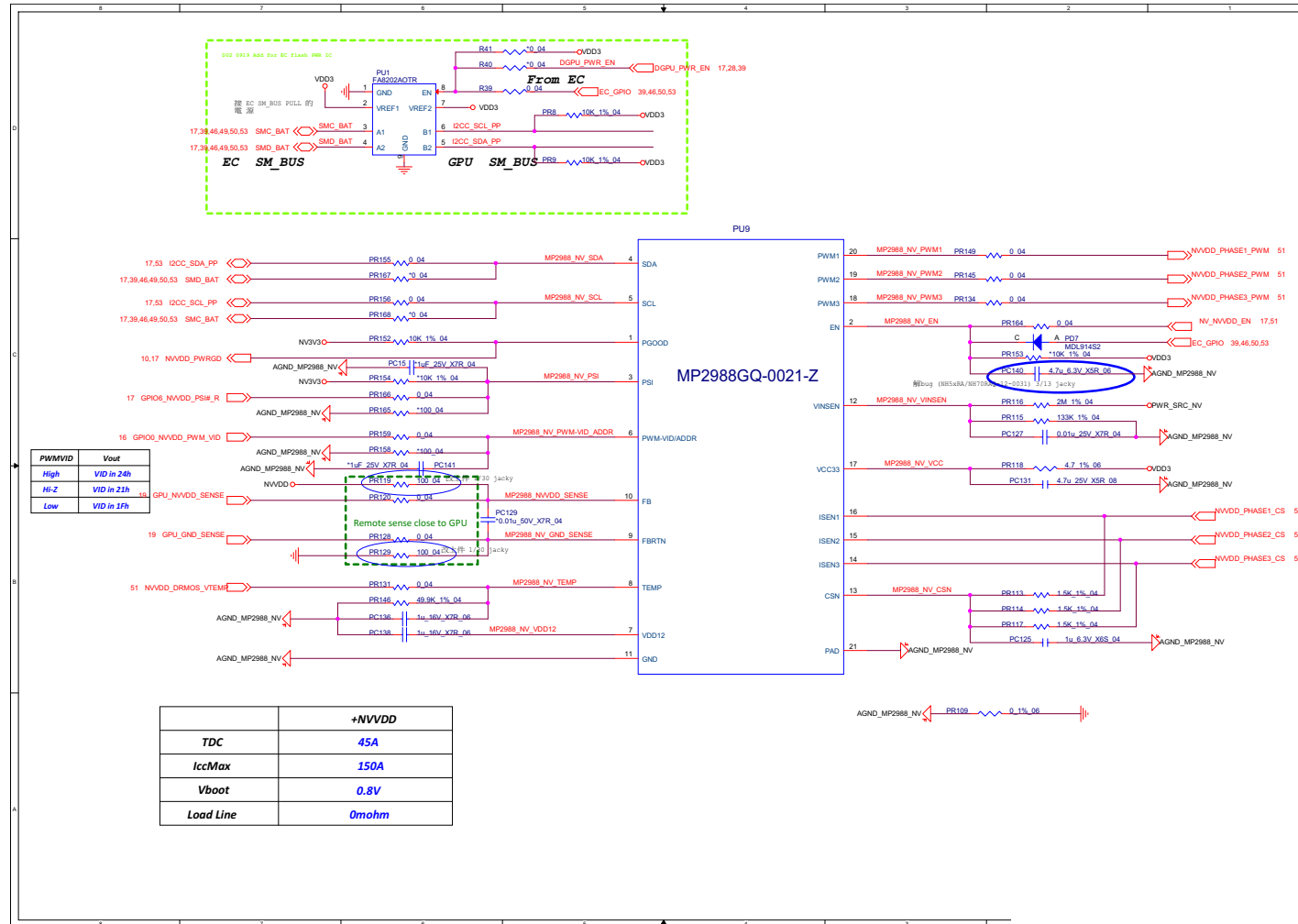

Sheet 50 of 64
NVVDD1

PEX_VDD

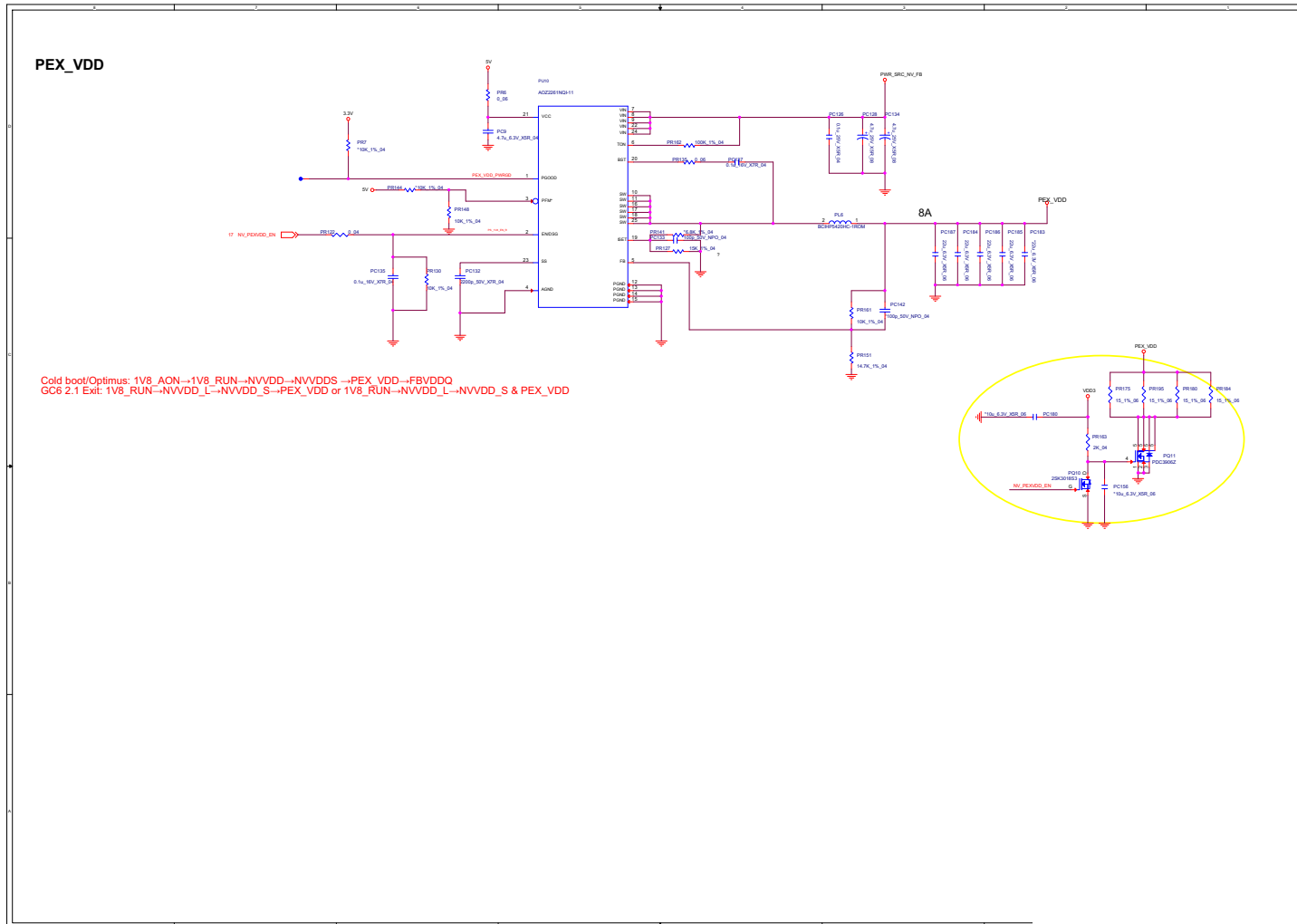

Sheet 52 of 64
PEX_VDD

Schematic Diagrams

FBVDDQ

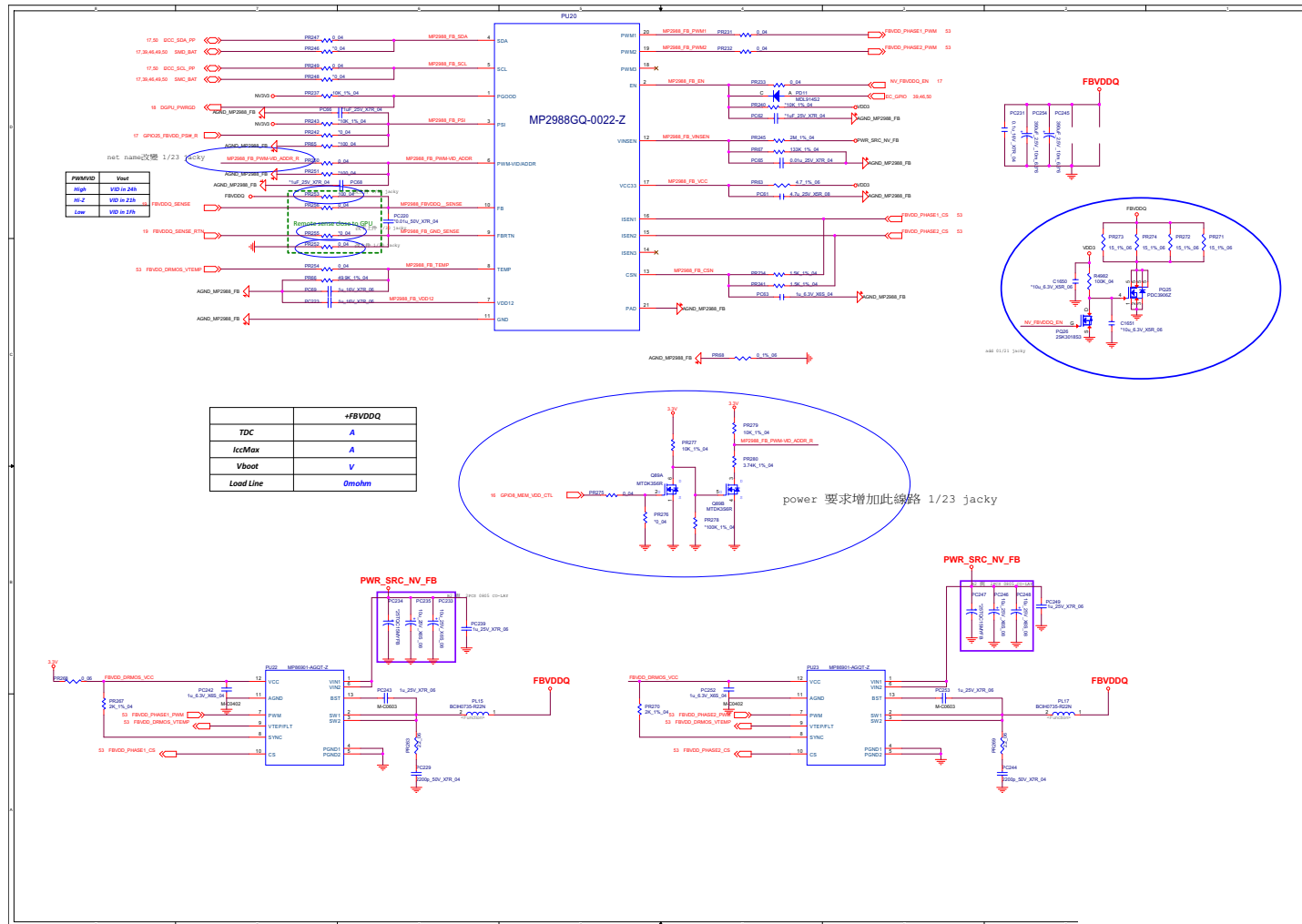

Sheet 53 of 64
FBVDDQ

B.Schematic Diagrams

1V8_RUN/AON

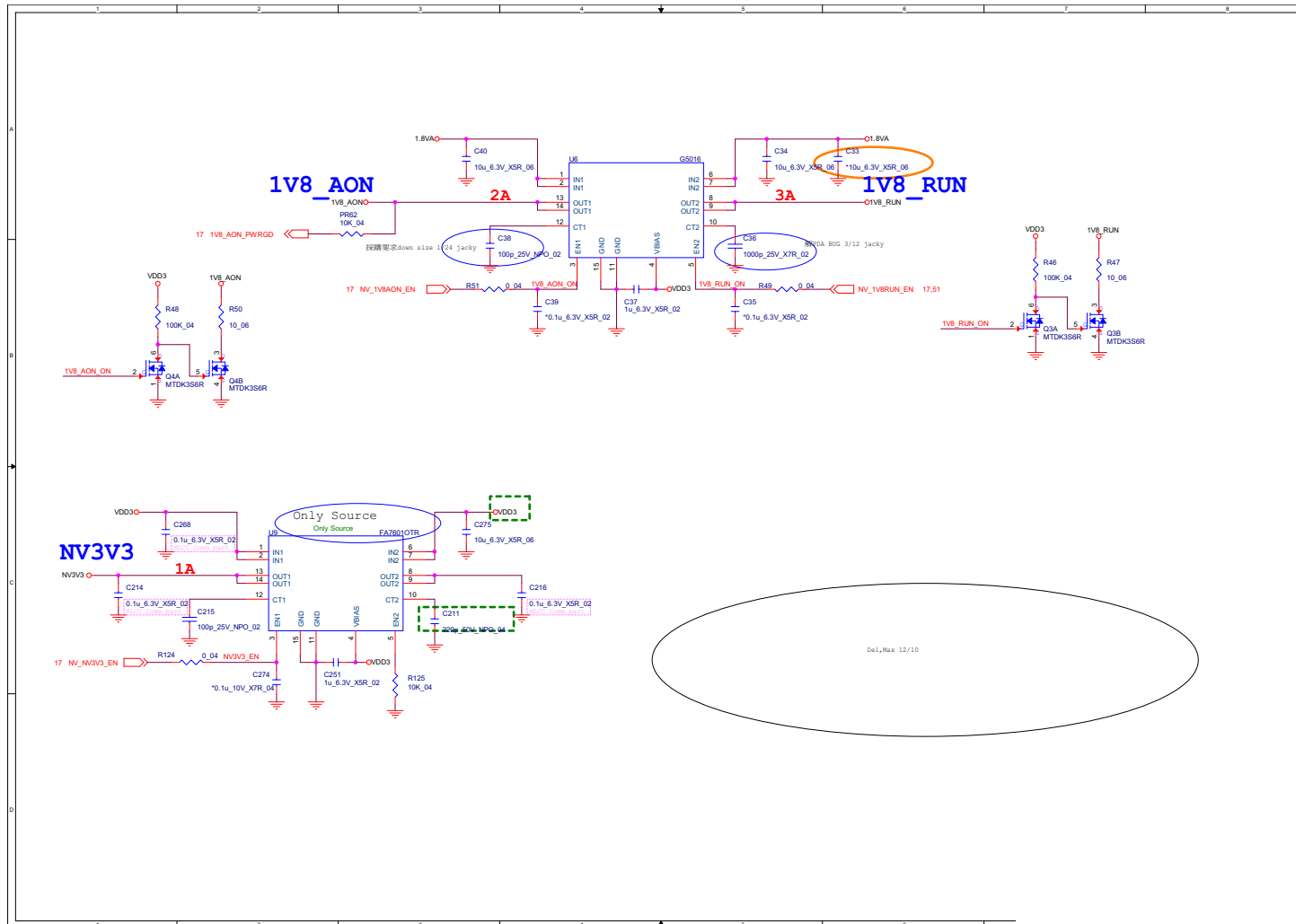

Sheet 54 of 64
1V8_RUN/AON

B.Schematic Diagrams

Audio Board

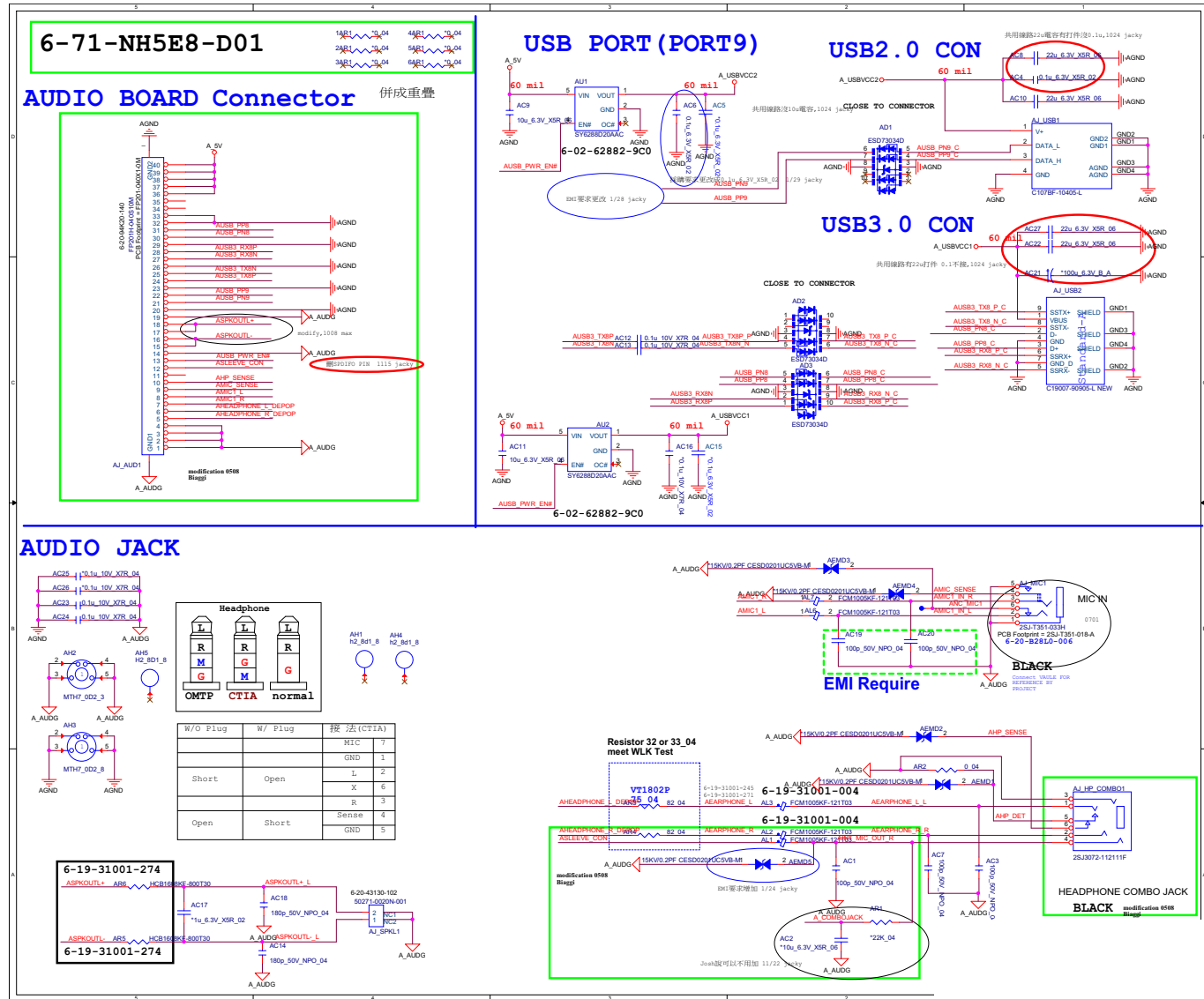

Sheet 55 of 64
Audio Board

NH50 PW Board

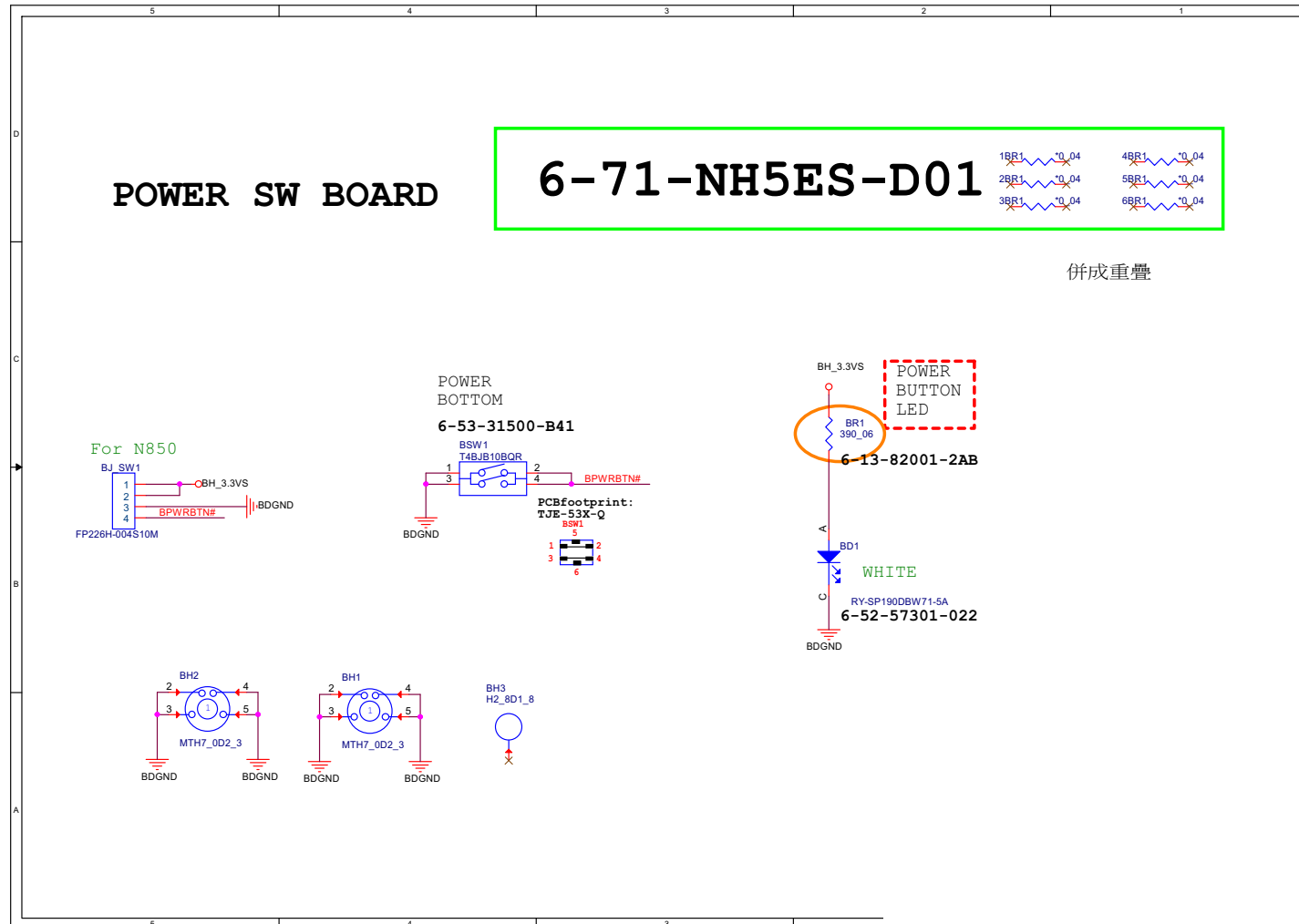

Sheet 56 of 64
NH50 PW Board

B.Schematic Diagrams

Hall Sensor Board

Sheet 57 of 64
Hall Sensor Board

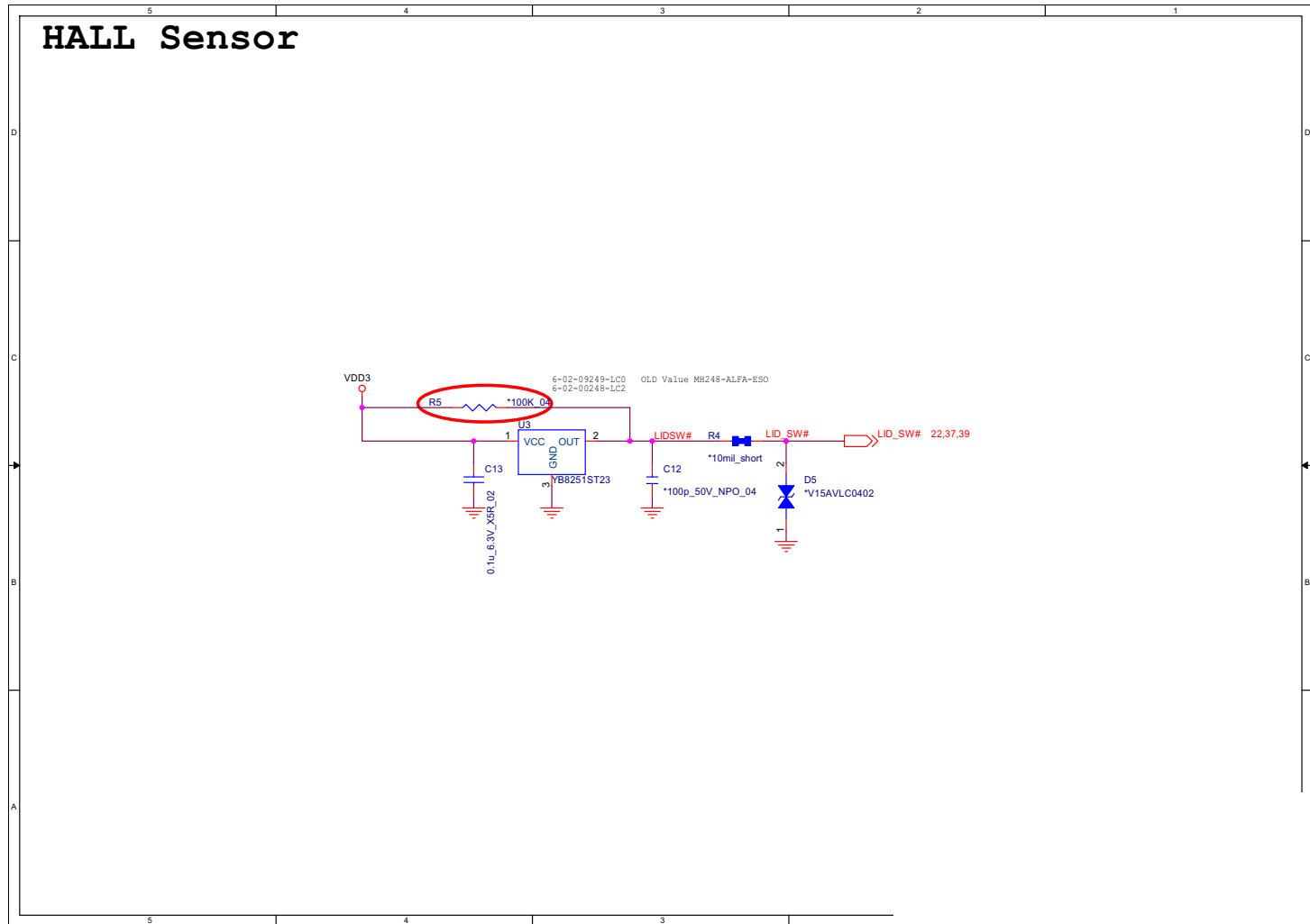

Click Board

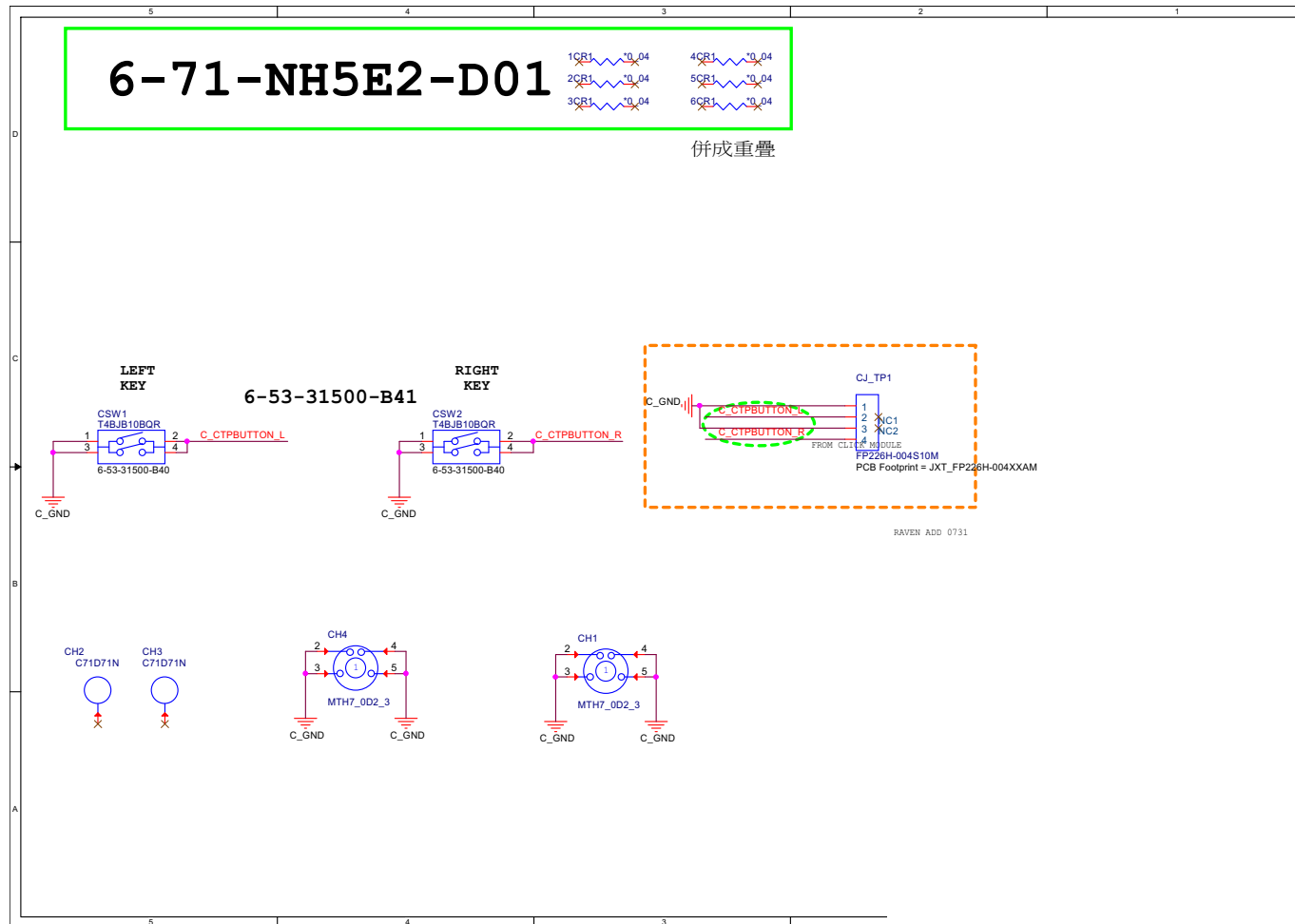

Sheet 58 of 64
Click Board

B.Schematic Diagrams

LED Board

Sheet 59 of 64
LED Board

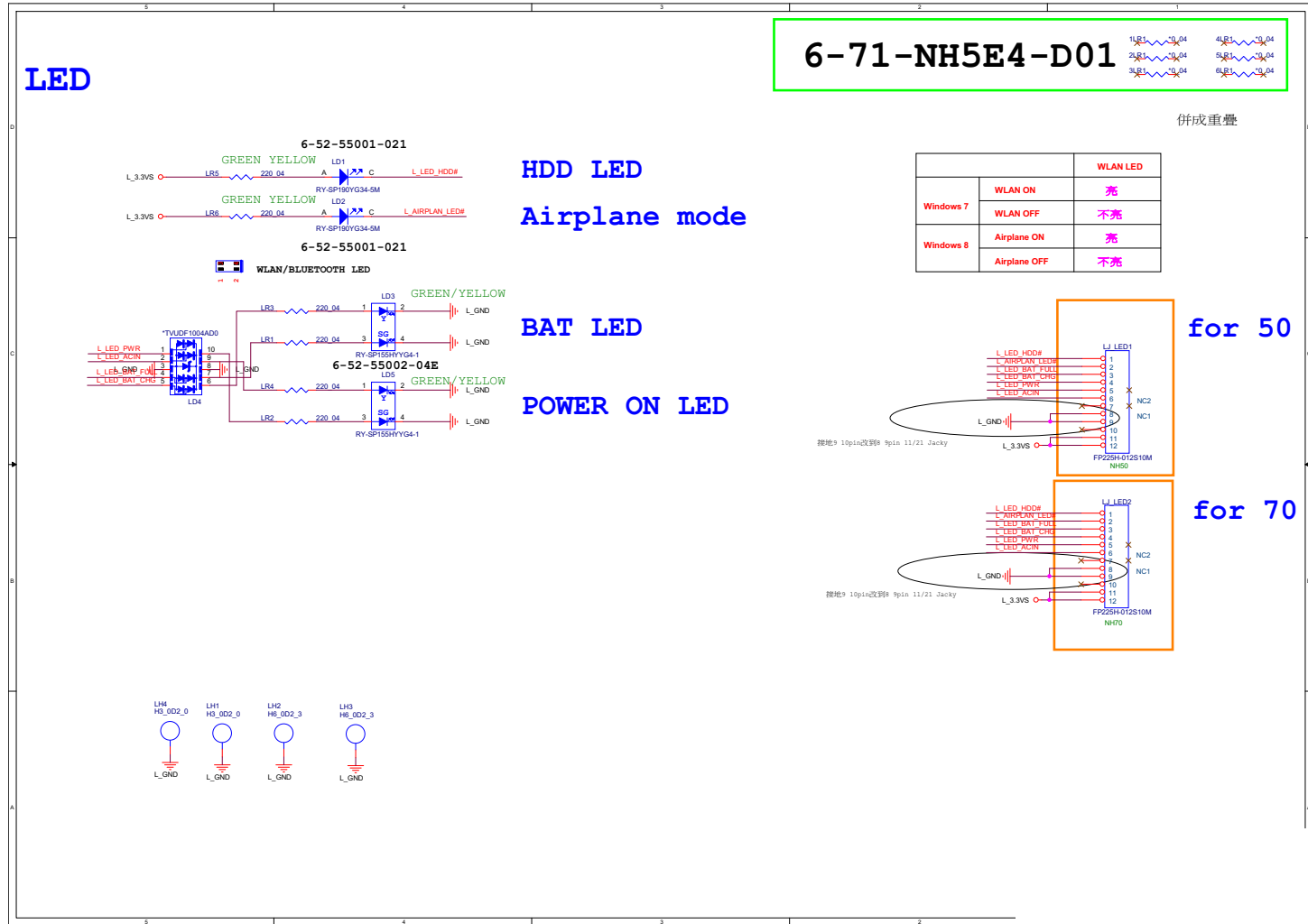

NH70 PW Board

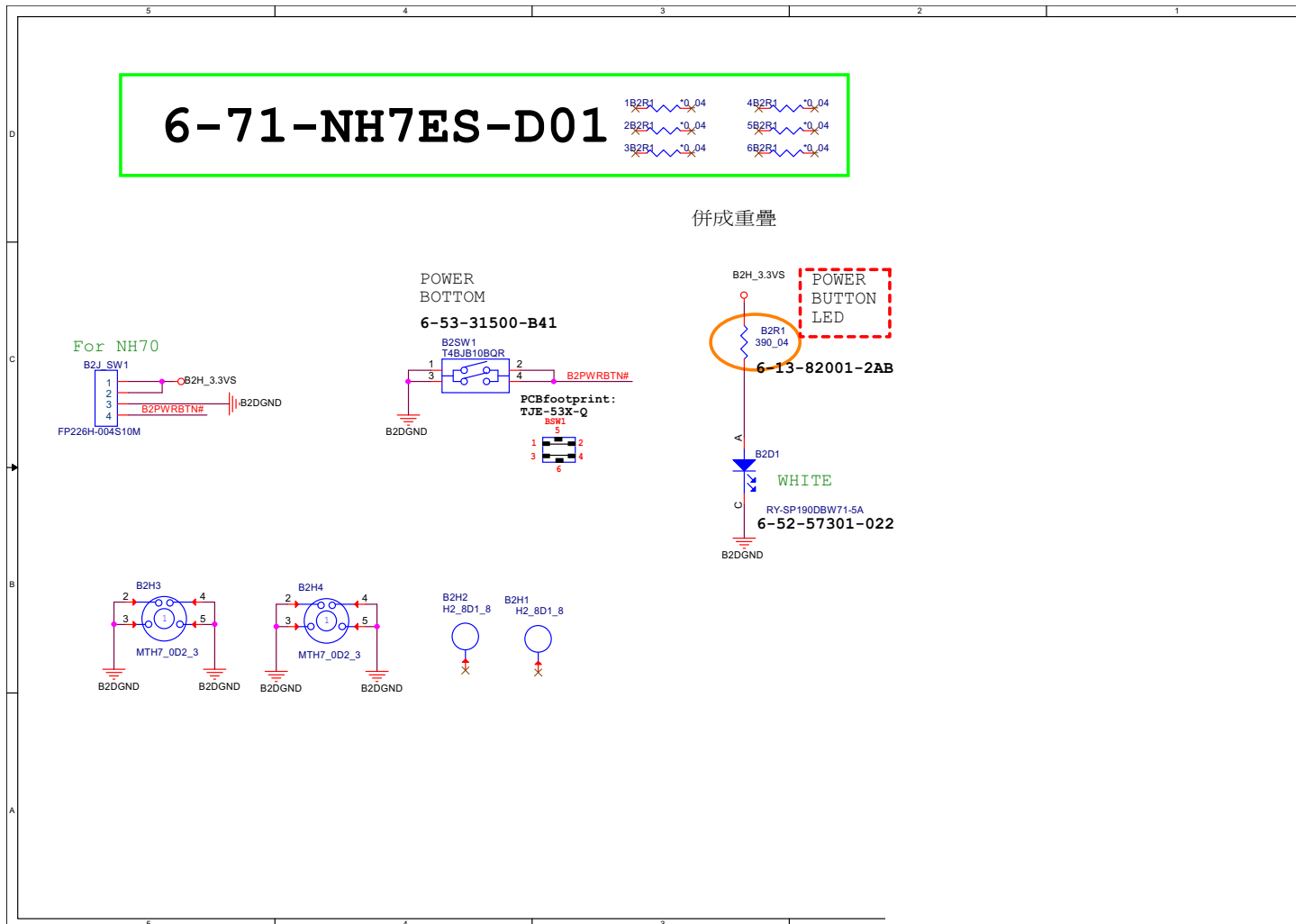

Sheet 60 of 64
NH70 PW Board

Power Measurement

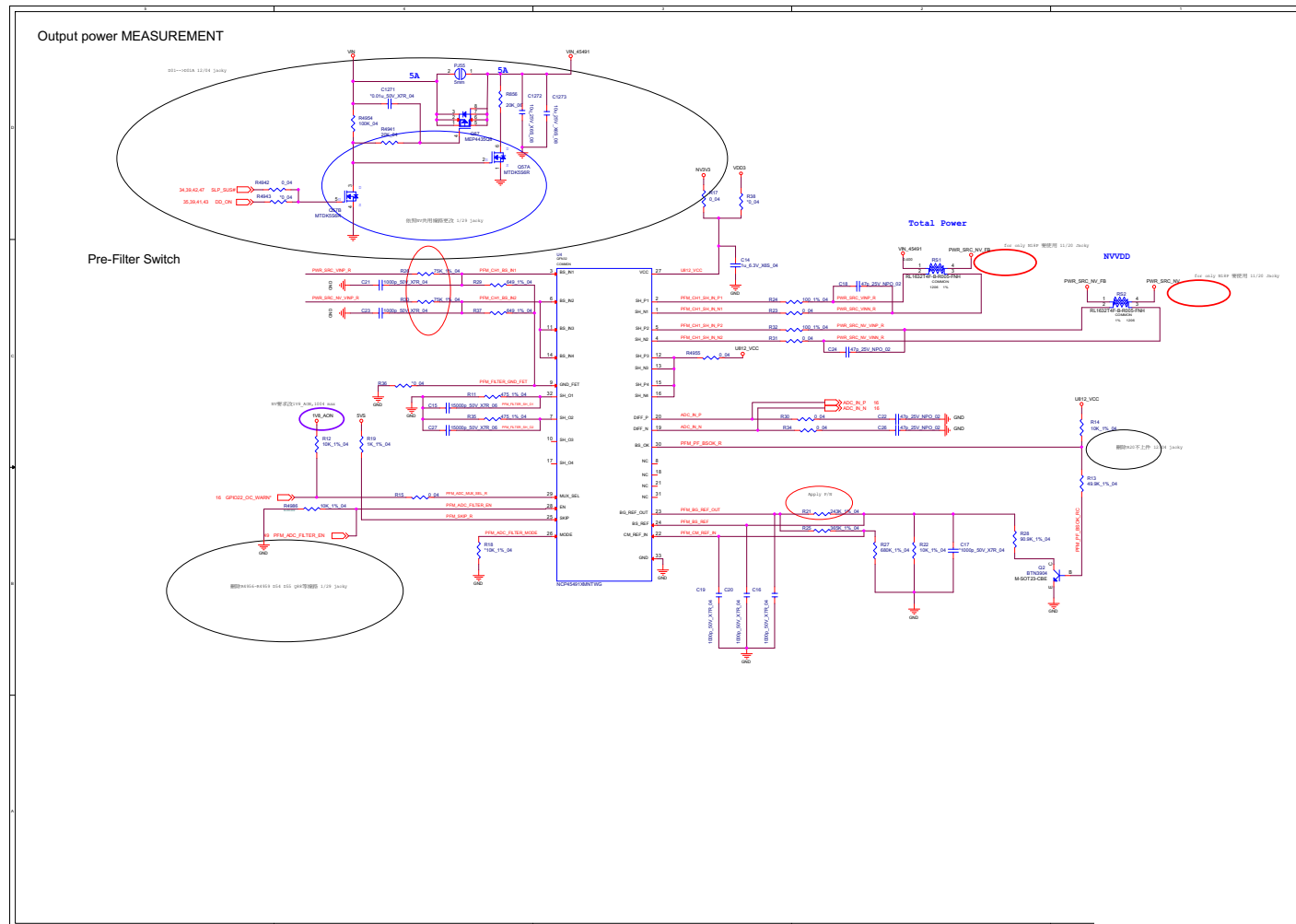

Sheet 62 of 64
Power
Measurement

B.Schematic Diagrams

Power Sequence

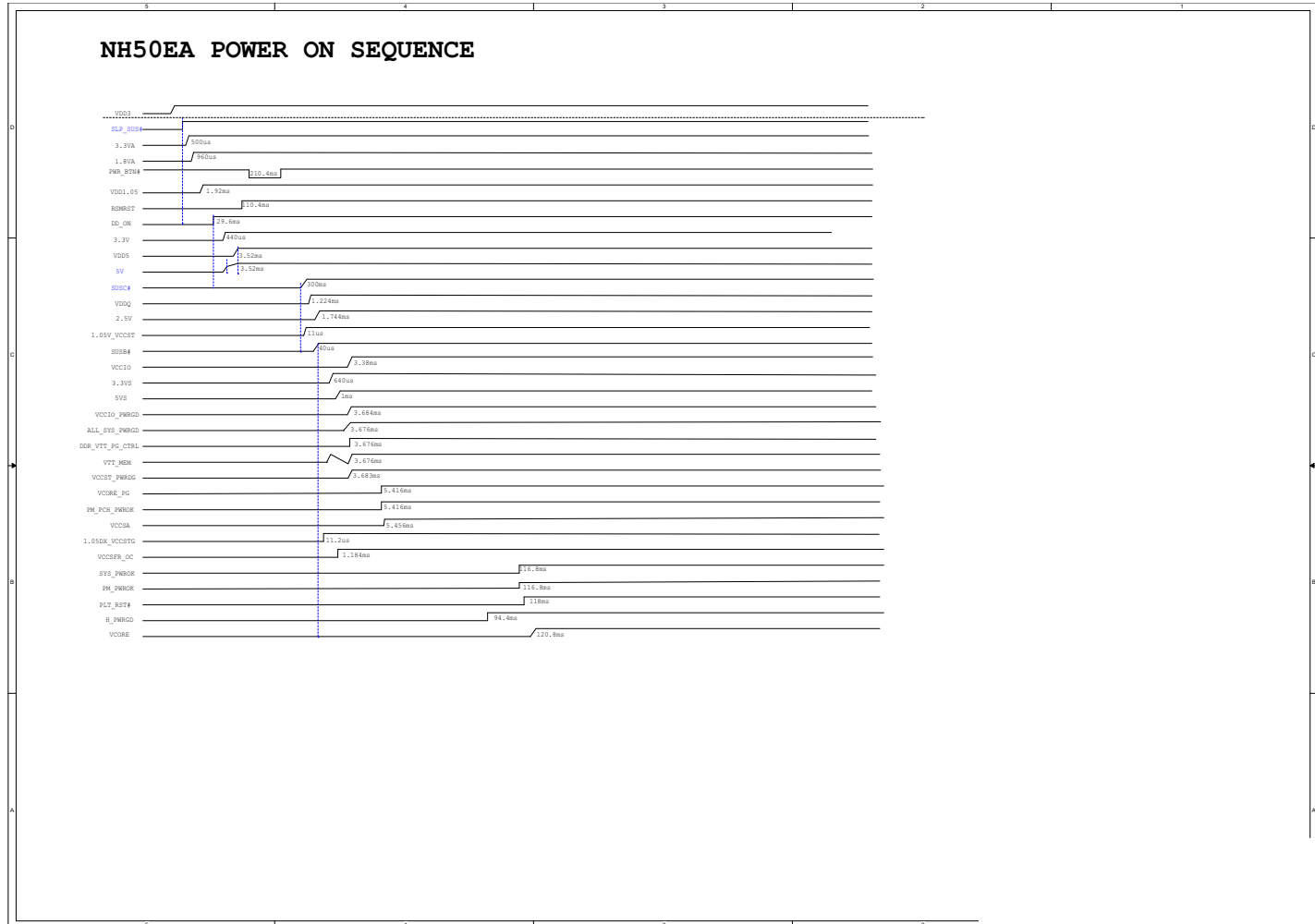

Sheet 63 of 64
Power Sequence

Schematic Diagrams