

SERVICE MANUAL

W760CUH / W765CUH

notebook



Notebook Computer
W760CU[H]/W765CU[H]
Service Manual

Notice

The company reserves the right to revise this publication or to change its contents without notice. Information contained herein is for reference only and does not constitute a commitment on the part of the manufacturer or any subsequent vendor. They assume no responsibility or liability for any errors or inaccuracies that may appear in this publication nor are they in anyway responsible for any loss or damage resulting from the use (or misuse) of this publication.

This publication and any accompanying software may not, in whole or in part, be reproduced, translated, transmitted or reduced to any machine readable form without prior consent from the vendor, manufacturer or creators of this publication, except for copies kept by the user for backup purposes.

Brand and product names mentioned in this publication may or may not be copyrights and/or registered trademarks of their respective companies. They are mentioned for identification purposes only and are not intended as an endorsement of that product or its manufacturer.

Version 1.0
March 2010

Trademarks

Intel and **Intel Core** are trademarks of Intel Corporation.

Windows[®] is a registered trademark of Microsoft Corporation.

Other brand and product names are trademarks and/or registered trademarks of their respective companies.

About this Manual

This manual is intended for service personnel who have completed sufficient training to undertake the maintenance and inspection of personal computers.

It is organized to allow you to look up basic information for servicing and/or upgrading components of the *W760CU[H]/W765CU[H]* series notebook PC.

The following information is included:

Chapter 1, Introduction, provides general information about the location of system elements and their specifications.

Chapter 2, Disassembly, provides step-by-step instructions for disassembling parts and subsystems and how to upgrade elements of the system.

Appendix A, Part Lists

Appendix B, Schematic Diagrams

IMPORTANT SAFETY INSTRUCTIONS

Follow basic safety precautions, including those listed below, to reduce the risk of fire, electric shock and injury to persons when using any electrical equipment:

1. Do not use this product near water, for example near a bath tub, wash bowl, kitchen sink or laundry tub, in a wet basement or near a swimming pool.
2. Avoid using a telephone (other than a cordless type) during an electrical storm. There may be a remote risk of electrical shock from lightning.
3. Do not use the telephone to report a gas leak in the vicinity of the leak.
4. Use only the power cord and batteries indicated in this manual. Do not dispose of batteries in a fire. They may explode. Check with local codes for possible special disposal instructions.
5. This product is intended to be supplied by a Listed Power Unit with an AC Input of 100 - 240V, 50 - 60Hz, DC Output of 19V, 4.74A (**90** Watts) minimum AC/DC Adapter.

CAUTION

Always disconnect all telephone lines from the wall outlet before servicing or disassembling this equipment.

**TO REDUCE THE RISK OF FIRE, USE ONLY NO. 26 AWG OR LARGER,
TELECOMMUNICATION LINE CORD**

This Computer's Optical Device is a Laser Class 1 Product

Instructions for Care and Operation

The notebook computer is quite rugged, but it can be damaged. To prevent this, follow these suggestions:

1. **Don't drop it, or expose it to shock.** If the computer falls, the case and the components could be damaged.



2. **Keep it dry, and don't overheat it.** Keep the computer and power supply away from any kind of heating element. This is an electrical appliance. If water or any other liquid gets into it, the computer could be badly damaged.

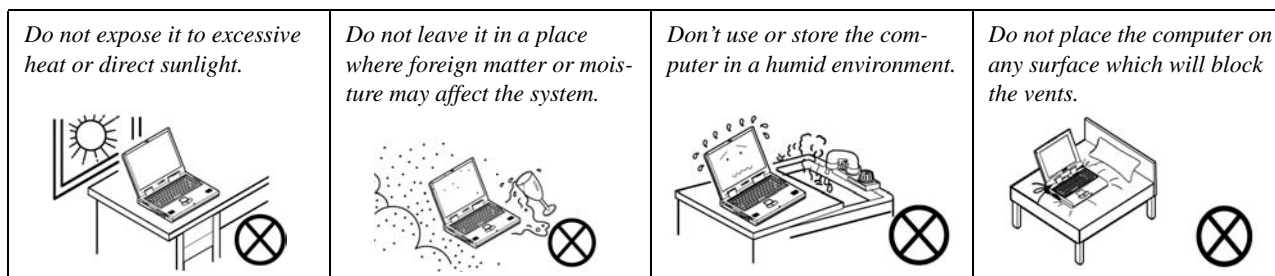

3. **Follow the proper working procedures for the computer.** Shut the computer down properly and don't forget to save your work. Remember to periodically save your data as data may be lost if the battery is depleted.

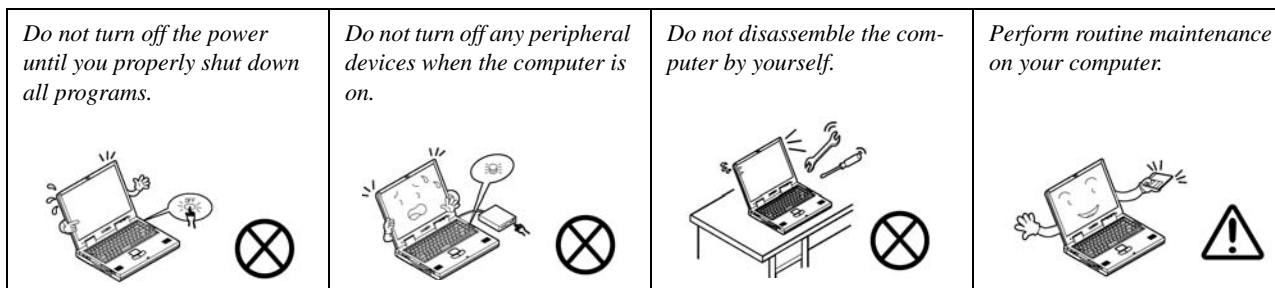

4. **Avoid interference.** Keep the computer away from high capacity transformers, electric motors, and other strong magnetic fields. These can hinder proper performance and damage your data.
5. **Take care when using peripheral devices.**

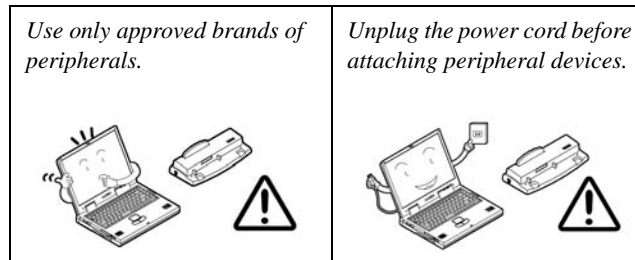

Power Safety

The computer has specific power requirements:

- Only use a power adapter approved for use with this computer.
- Your AC adapter may be designed for international travel but it still requires a steady, uninterrupted power supply. If you are unsure of your local power specifications, consult your service representative or local power company.
- The power adapter may have either a 2-prong or a 3-prong grounded plug. The third prong is an important safety feature; do not defeat its purpose. If you do not have access to a compatible outlet, have a qualified electrician install one.
- When you want to unplug the power cord, be sure to disconnect it by the plug head, not by its wire.
- Make sure the socket and any extension cord(s) you use can support the total current load of all the connected devices.
- Before cleaning the computer, make sure it is disconnected from any external power supplies.

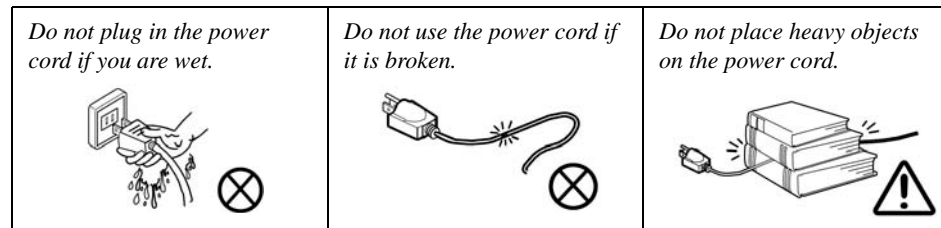

Power Safety Warning

Before you undertake any upgrade procedures, make sure that you have turned off the power, and disconnected all peripherals and cables (including telephone lines). It is advisable to also remove your battery in order to prevent accidentally turning the machine on.

Battery Precautions

- Only use batteries designed for this computer. The wrong battery type may explode, leak or damage the computer.
- Do not continue to use a battery that has been dropped, or that appears damaged (e.g. bent or twisted) in any way. Even if the computer continues to work with a damaged battery in place, it may cause circuit damage, which may possibly result in fire.
- Recharge the batteries using the notebook's system. Incorrect recharging may make the battery explode.
- Do not try to repair a battery pack. Refer any battery pack repair or replacement to your service representative or qualified service personnel.
- Keep children away from, and promptly dispose of a damaged battery. Always dispose of batteries carefully. Batteries may explode or leak if exposed to fire, or improperly handled or discarded.
- Keep the battery away from metal appliances.
- Affix tape to the battery contacts before disposing of the battery.
- Do not touch the battery contacts with your hands or metal objects.

Battery Guidelines

The following can also apply to any backup batteries you may have.

- If you do not use the battery for an extended period, then remove the battery from the computer for storage.
- Before removing the battery for storage charge it to 60% - 70%.
- Check stored batteries at least every 3 months and charge them to 60% - 70%.



Battery Disposal

The product that you have purchased contains a rechargeable battery. The battery is recyclable. At the end of its useful life, under various state and local laws, it may be illegal to dispose of this battery into the municipal waste stream. Check with your local solid waste officials for details in your area for recycling options or proper disposal.

Caution

Danger of explosion if battery is incorrectly replaced. Replace only with the same or equivalent type recommended by the manufacturer. Discard used battery according to the manufacturer's instructions.

Battery Level

Click the battery icon  in the taskbar to see the current battery level and charge status. A battery that drops below a level of 10% will not allow the computer to boot up. Make sure that any battery that drops below 10% is recharged within one week.

Related Documents

You may also need to consult the following manual for additional information:

User's Manual on CD

This describes the notebook PC's features and the procedures for operating the computer and its ROM-based setup program. It also describes the installation and operation of the utility programs provided with the notebook PC.

Contents

Introduction	1-1	Top with Fingerprint (W760CU[H])	A-3
Overview	1-1	Top with Fingerprint (W765CU[H])	A-4
System Specifications	1-2	Top without Fingerprint (W760CU[H])	A-5
External Locator - Top View with LCD Panel Open	1-4	Top without Fingerprint (W765CU[H])	A-6
External Locator - Front & Right side Views	1-5	Bottom	A-7
External Locator - Left Side & Rear View	1-6	LCD	A-8
External Locator - Bottom View	1-7	COMBO	A-9
Mainboard Overview - Top (Key Parts)	1-8	DVD-Dual Drive	A-10
Mainboard Overview - Bottom (Key Parts)	1-9	Schematic Diagrams.....	B-1
Mainboard Overview - Top (Connectors)	1-10	System Block Diagram	B-2
Mainboard Overview - Bottom (Connectors)	1-11	Clock Generator	B-3
Disassembly	2-1	Processor 1/7	B-4
Overview	2-1	Processor 2/7	B-5
Maintenance Tools	2-2	Processor 3/7	B-6
Connections	2-2	Processor 4/7	B-7
Maintenance Precautions	2-3	Processor 5/7	B-8
Disassembly Steps	2-4	Processor 6/7	B-9
Removing the Battery	2-5	Processor 7/7	B-10
Removing the Hard Disk Drive	2-6	DDRIII SO-DIMM_0	B-11
Removing the Optical (CD/DVD) Device	2-8	DDRIII SO-DIMM_1	B-12
Removing the System Memory (RAM)	2-9	Panel, Inverter, CRT	B-13
Removing the Inverter Board	2-11	M92 S2 PCIE Interface	B-14
Removing the Wireless LAN Module	2-12	M92 S2 Main Generic	B-15
Removing and Installing the Processor	2-13	M92 S2 DP Power	B-16
Removing the Bluetooth Module	2-15	M92 S2 Power	B-17
Removing the Keyboard	2-16	M92 S2 MEM Interface	B-18
Removing the Modem	2-17	M92 S2 DDR2 Memory	B-19
Part Lists	A-1	M92 S2 LVDS & Straps	B-20
Part List Illustration Location	A-2	IBEXPEAK - M 1/9	B-21
		IBEXPEAK - M 2/9	B-22



Preface

IBEXPEAK - M 3/9	B-23	Click Finger Board for M77	B-55
IBEXPEAK - M 4/9	B-24	Multi Function Board	B-56
IBEXPEAK - M 5/9	B-25		
IBEXPEAK - M 6/9	B-26		
IBEXPEAK - M 7/9	B-27		
IBEXPEAK - M 8/9	B-28		
IBEXPEAK - M 9/9	B-29		
New Card, Mini PCIE	B-30		
3G, TPM	B-31		
USB, Fan, TP, FP, Multi Con	B-32		
Card Reader (JMC251)	B-33		
SATA ODD, LED, Hotkey, LID, SW	B-34		
LAN, Modem	B-35		
Audio Codec ALC272	B-36		
KBC-ITE IT8502E	B-37		
5VS, 3VS, 3.3VM, 1.05VS, VIN1	B-38		
Power 3.3V/5V	B-39		
Power 1.8V	B-40		
Power 1.5V/0.75V	B-41		
Power 1.1VS_VTT	B-42		
Power VGFX_CORE	B-43		
V-Core	B-44		
M92 VDDC	B-45		
AC-IN, Charger	B-46		
HDMI	B-47		
Audio Board	B-48		
Finger Sensor Board TCS4X	B-49		
Power Switch Board for M74	B-50		
Finger Board for M74	B-51		
Power Switch Board for M76	B-52		
External ODD Board for W76	B-53		
ODD Board for M760T	B-54		

Chapter 1: Introduction

Overview

This manual covers the information you need to service or upgrade the **W760CU[H]/W765CU[H]** series notebook computer. Information about operating the computer (e.g. getting started, and the *Setup* utility) is in the *User's Manual*. Information about drivers (e.g. VGA & audio) is also found in *User's Manual*. That manual is shipped with the computer.

Operating systems (e.g. *Windows 7*, *Windows Vista*, etc.) have their own manuals as do application software (e.g. word processing and database programs). If you have questions about those programs, you should consult those manuals.

The **W760CU[H]/W765CU[H]** series notebook is designed to be upgradeable. See [Disassembly on page 2 - 1](#) for a detailed description of the upgrade procedures for each specific component. Please note the warning and safety information indicated by the “” symbol.

The balance of this chapter reviews the computer's technical specifications and features.

System Specifications

<p>Processor</p> <p>Intel® Core i7-820QM Processor: 1.73GHz 45nm (45 Nanometer) Process Technology, 8M L3 Cache & FSB 1333MHz - TDP 45W rPGA988A Package</p> <p>Intel® Core i7-720QM Processor: 1.6GHz 45nm (45 Nanometer) Process Technology, 6M L3 Cache & FSB 1333MHz - TDP 45W rPGA988A Package</p> <p>Intel® Core i7-620M Processor: 2.66GHz 32nm (32 Nanometer) Process Technology, 4M L3 Cache & FSB 1066MHz - TDP 35W rPGA988A Package</p> <p>Intel® Core i5-540M / i5-520M Processor: 2.53GHz / 2.40GHz 32nm (32 Nanometer) Process Technology, 3M L3 Cache & FSB 1066MHz - TDP 35W rPGA988A Package</p> <p>Intel® Core i5-430M Processor: 2.27GHz 32nm (32 Nanometer) Process Technology, 3M L3 Cache & FSB 1066MHz - TDP 35W rPGA988A Package</p>	<p>Processor (cont'd)</p> <p>Intel® Core i5-350M / i5-330M Processor: 2.27GHz / 2.13GHz 32nm (32 Nanometer) Process Technology, 3M L3 Cache & FSB 1066MHz - TDP 35W rPGA988A Package</p> <p>Core Logic</p> <p>Intel® HM55 Chipset</p> <p>Display</p> <p>15.6" HD TFT LCD</p> <p>Memory</p> <p>64-bit Wide DDRIII (DDR3) Data Channel Two 204 Pin SO-DIMM Sockets Supporting DDRIII (DDR3) 1066/1333MHz Memory Expandable up to 4GB (1GB / 2GB DDRIII Modules)</p> <p>Video Adapter</p> <p>ATI Mobility Radeon HD 4570 Discrete Graphics On Board (PCIe 2.0 * 8) 512MB GDDR2 Video RAM on board Supports Microsoft DirectX® 10 Supports HDCP</p> <p>BIOS</p> <p>One 32Mb SPI Flash ROM Phoenix™ BIOS</p>	<p>Storage</p> <p>One Changeable 12.7mm(h) Optical Device (CD/DVD) Type Drive (Super Multi Drive Module, Blu-Ray Combo Module)</p> <p>Easy Changeable 2.5" 9.5 mm (h) SATA (Serial) HDD</p> <p>Audio</p> <p>High Definition Audio Compliant Interface 3D Stereo Enhanced Sound System S/PDIF Digital Output Built-In Microphone 2 * Built-In Speakers 1W, 8Ω</p> <p>Keyboard & Pointing Device</p> <p>Full Size WinKey Keyboard Built-in TouchPad (integrated scrolling key functionality) with Multi Gesture Function Three Instant Keys (WWW, E-Mail, Silent Mode)</p> <p>Interface</p> <p>Three USB 2.0 Ports One eSATA Port (Supported in Windows Vista/Windows 7 Only) One HDMI Out Port One External Monitor Port One Headphone-Out Jack One Microphone-In Jack One S/PDIF-Out Jack One RJ-11 Jack One RJ-45 LAN Jack One DC-In Jack</p>
--	--	---

Card Reader	Communication	Power
Embedded 7-in-1 Card Reader (MS/ MS Pro/ SD/ Mini SD/ MMC/ RS MMC/ MS Duo) Note: MS Duo/ Mini SD/ RS MMC Cards require a PC adapter	Built-In 56K MDC Modem V.90 & V.92 Compliant Built-In Gigabit Ethernet LAN Intel® WiFi Link Module 5300 3*3 802.11 a/g/n HMC with PCIe Interface (Factory Option) Intel® Advanced N WiFi Link 6200 Wireless LAN Module 802.11 a/g/n 612AN Half Mini-Card with PCIe Interface (Factory Option) Intel® Ultimate N WiFi Link 6300 Wireless LAN Module 802.11 a/g/n 633AN Half Mini-Card with PCIe Interface (Factory Option) 3rd Party 802.11b/g HMC Wireless Lan Module with PCIe Interface (Factory Option) 3rd Party 802.11b/g/n HMC Wireless Lan Module with PCIe Interface (Factory Option) Bluetooth 2.1 + EDR (Enhanced Data Rate) Module (Factory Option) 2.0M Pixel USB PC Camera Module (Factory Option) UMTS/HSPDA-based 3.75G Module with USB Mini-Card Interface (Factory Option) Quad-band GSM/GPRS (850 MHz, 900 MHz, 1800 MHz, 1900 MHz) UMTS WCDMA FDD (2100 MHz) Note that UMTS modes CAN NOT be used in North America.	Full Range AC/DC Adapter AC input 100 - 240V, 50 - 60Hz, DC Output 19V, 4.74A (90 Watts) 6 Cell Smart Lithium-Ion Battery Pack, 4400mAH 9 Cell Smart Lithium-Ion Battery Pack, 7200mAH (Option)
Slots	Power Management	Environmental Spec
One ExpressCard/34/54 Slot Two Mini-Card Slots (USB/PCIe): Slot 1 for WLAN Module with HMC Slot and PCIe Interface Slot 2 for 3.75G Mini-Card Slot with USB Interface (Factory Option)	Supports Wake on LAN Supports Wake on USB Supports Resume From Modem Ring	Temperature Operating: 5°C - 35°C Non-Operating: -20°C - 60°C Relative Humidity Operating: 20% - 80% Non-Operating: 10% - 90%
Security	Dimensions & Weight	
Security (Kensington® Type) Lock Slot BIOS Password Fingerprint Reader Module (Factory Option)	397.2mm (w) * 282.5mm (d) * 39.5mm (h) 2.9 kg With 6 Cell Battery & ODD	
Operating System		
Windows® Vista (with Service Pack 2) Windows® 7		

Introduction

Figure 1
Top View

External Locator - Top View with LCD Panel Open

1. Optional Built-In PC Camera
2. LCD
3. Speakers
4. Power Button
5. Hot Key Buttons
6. Keyboard
7. Built-In Microphone
8. Touchpad & Buttons
9. Fingerprint Module (Optional)
10. LED Indicators

***Note:** This model may have either a fingerprint module or card reader module, depending on the purchase configuration.

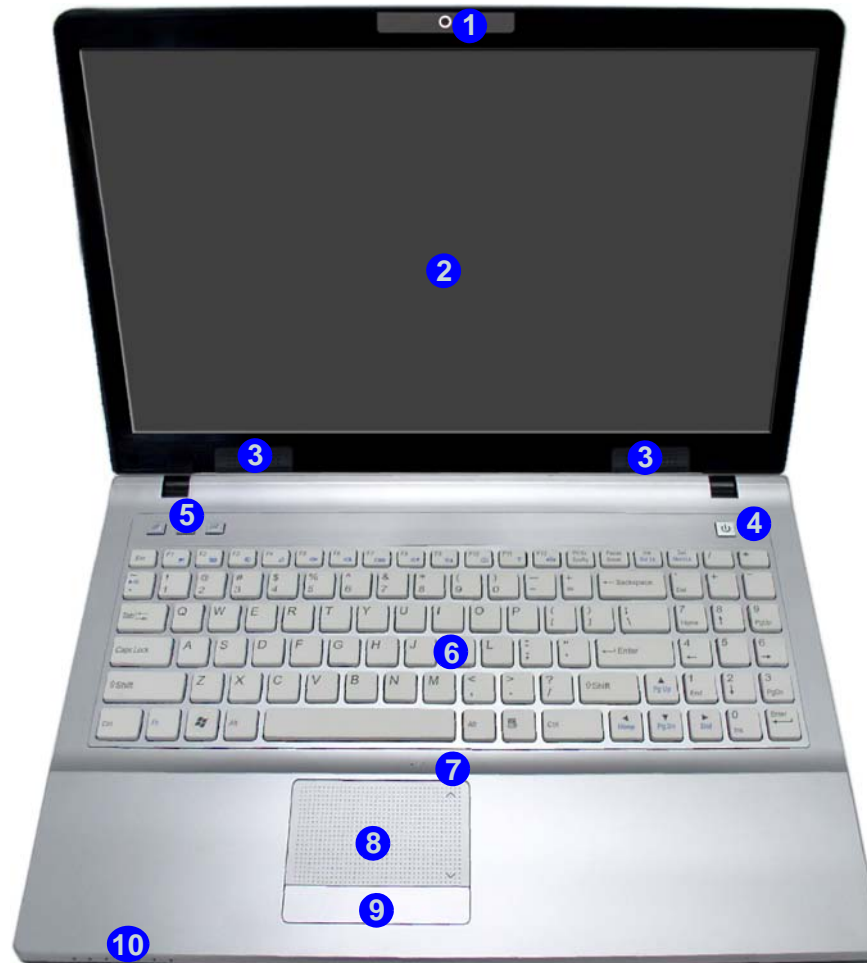

External Locator - Front & Right side Views



Figure 2

Front Views

1. LED Power & Communication Indicators



Figure 3

Right Side Views

1. S/PDIF-Out Jack
2. Microphone-In Jack
3. Headphone-Out Jack
4. USB 2.0 Port
5. Optical Device Drive Bay
6. RJ-11 Phone Jack
7. Security Lock Slot

Introduction

External Locator - Left Side & Rear View

Figure 4
Left Side View

1. DC-In Jack
2. External Monitor Port
3. RJ-45 LAN Jack
4. Vent
5. 2 * USB 2.0 Ports
6. ExpressCard Slot
7. 7-in-1 Card Reader



Figure 5
Rear View

1. Battery

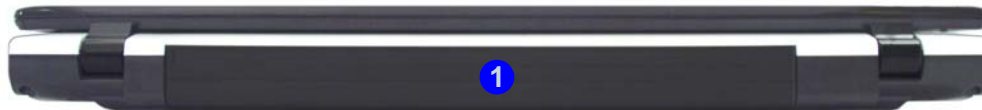

External Locator - Bottom View

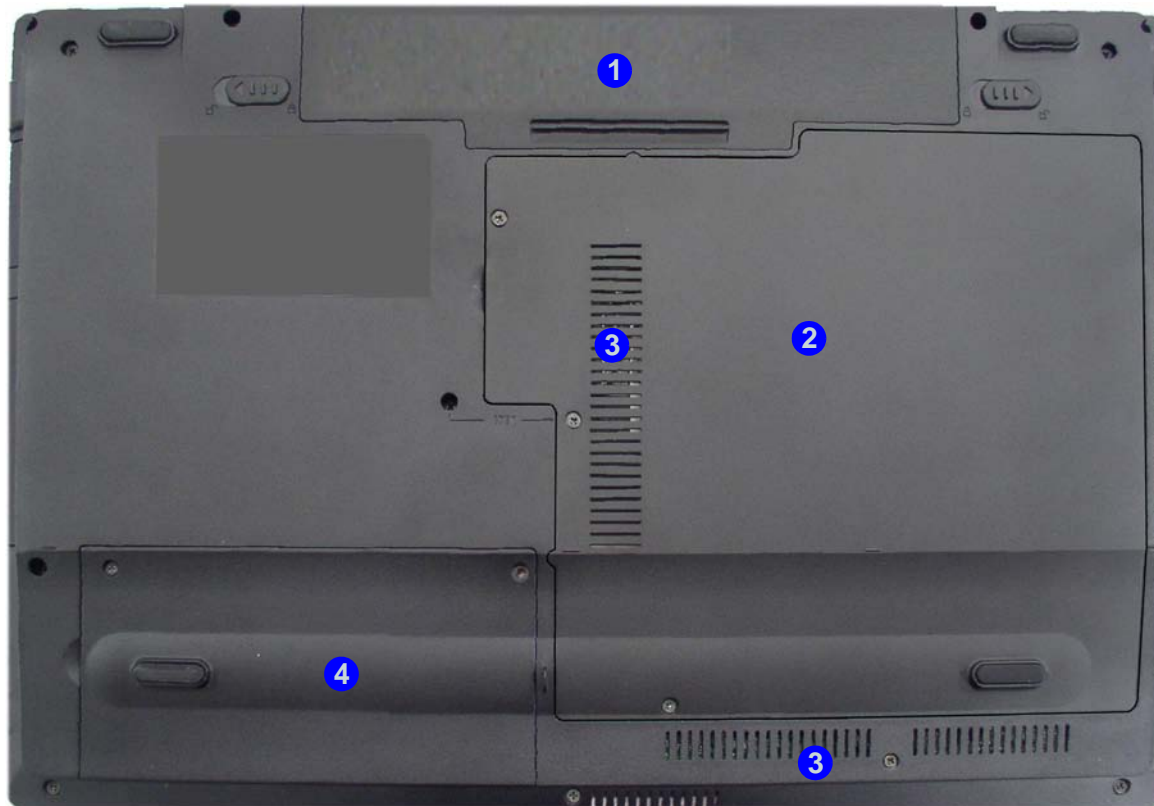

Figure 6
Bottom View

1. Battery
2. RAM & CPU Bay Cover
3. Vent/Fan Intake/Outlet
4. Hard Disk Bay Cover



Overheating

To prevent your computer from overheating make sure nothing blocks the vent/fan intakes while the computer is in use.

Introduction

Figure 7
**Mainboard Top
Key Parts**

1. Transformer
2. PS810L
3. ExpressCard Connector
4. KBC ITE IT8512E

Mainboard Overview - Top (Key Parts)

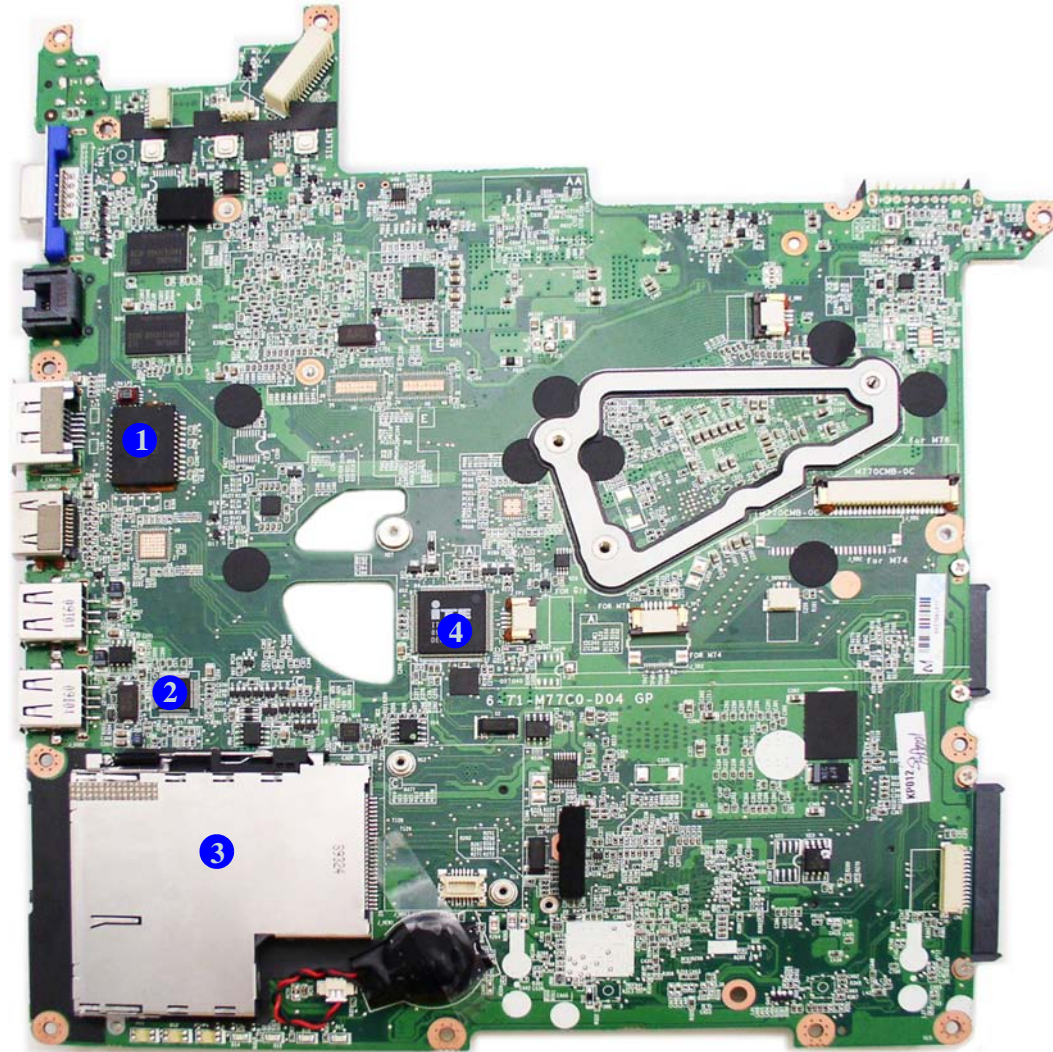

Mainboard Overview - Bottom (Key Parts)

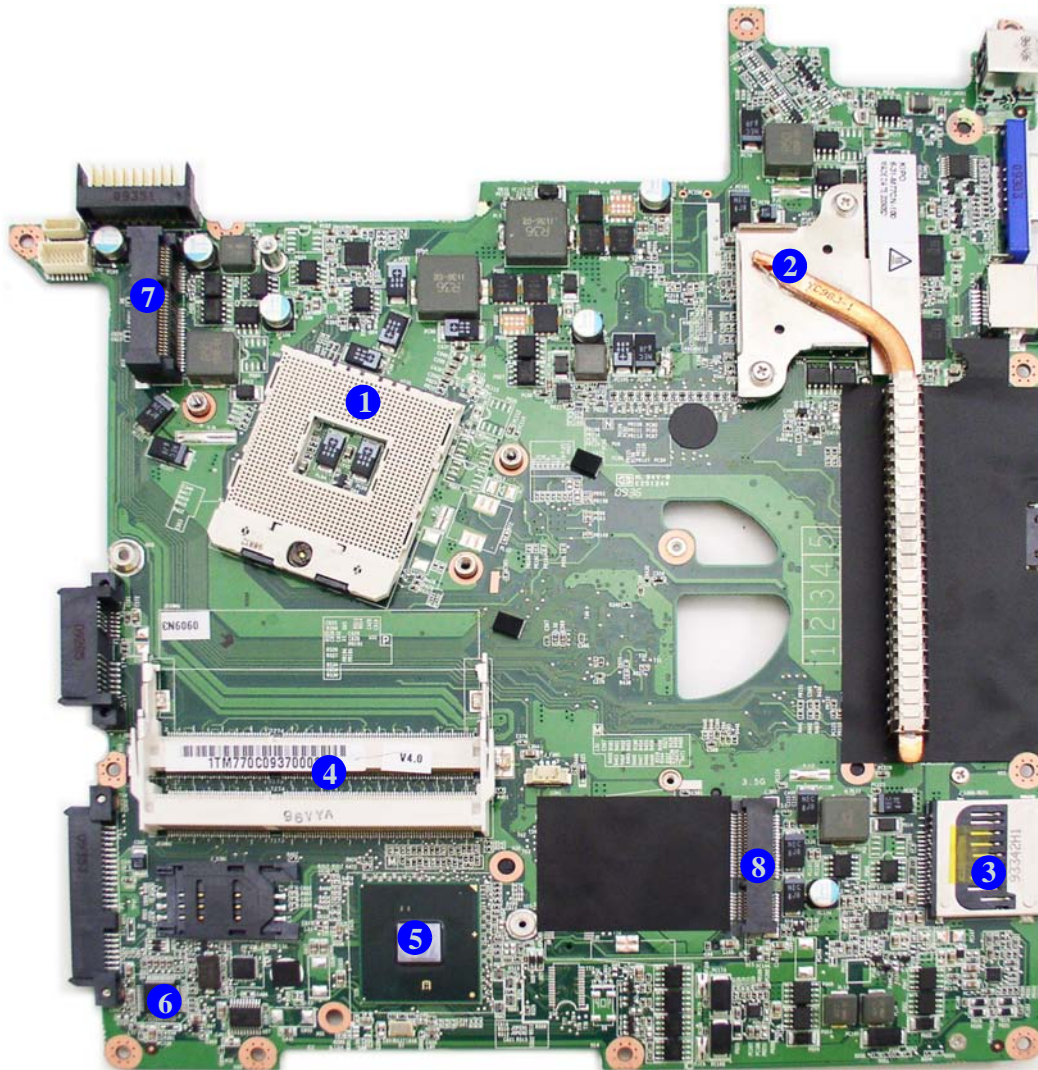

Figure 8
**Mainboard Bottom
Key Parts**

1. CPU Socket (no CPU installed)
2. GPU ATI 4570
3. Card Reader Socket
4. Memory Slots DDR3 SO-DIMM
5. Intel PM55
6. Audio Codec
7. Mini-Card Connector (WLAN Module)
8. Mini-Card Connector (3G Module)

Introduction

Figure 9
**Mainboard Top
Connectors**

Mainboard Overview - Top (Connectors)

1. USB Port
2. Inverter Connector
3. Speaker Connector
4. LCD Cable Connector
5. Power Board Connector
6. Keyboard Cable Connector
7. Audio Board Connector
8. Microphone Cable Connector
9. TouchPad Cable Connector
10. Fingerprint Connector
11. Modem Connector

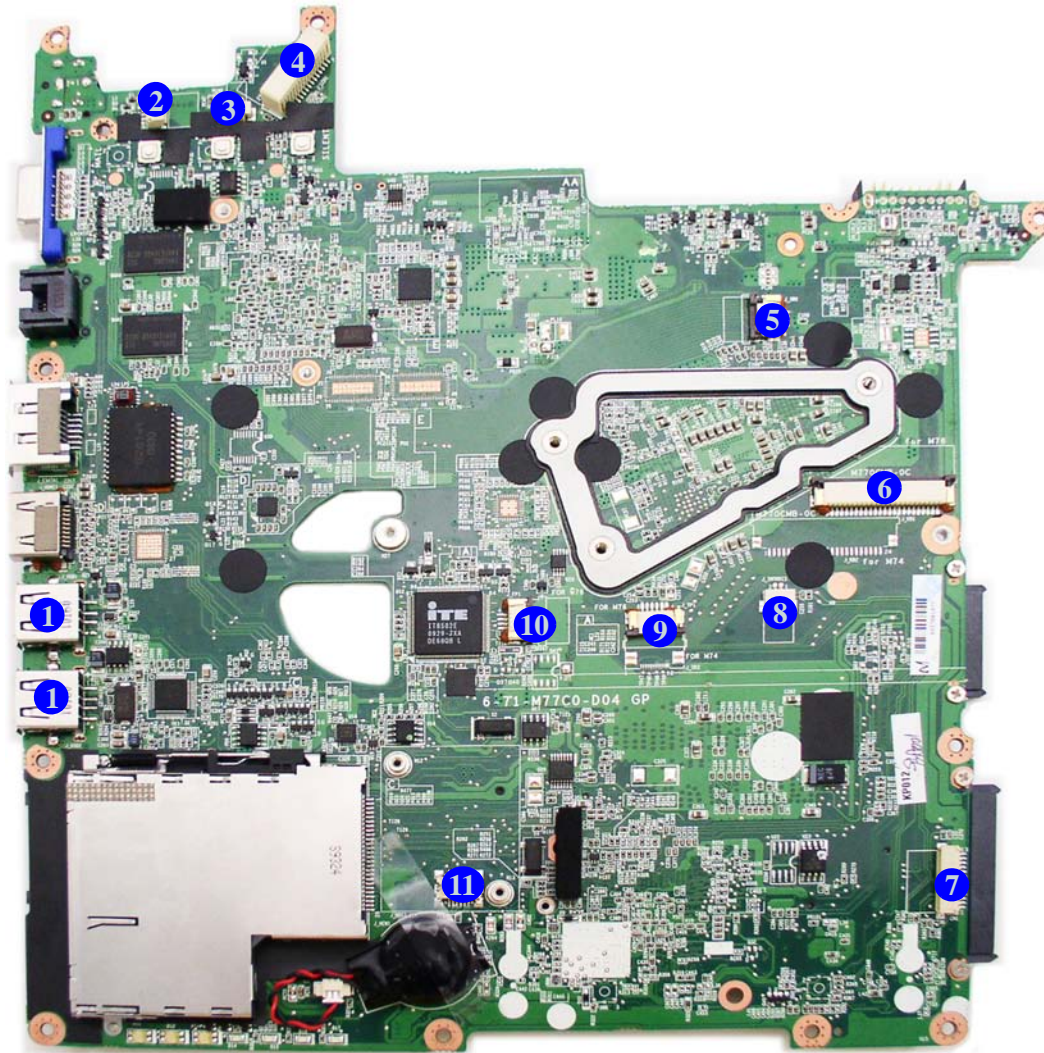

Mainboard Overview - Bottom (Connectors)

Figure 10
**Mainboard Bottom
Connectors**

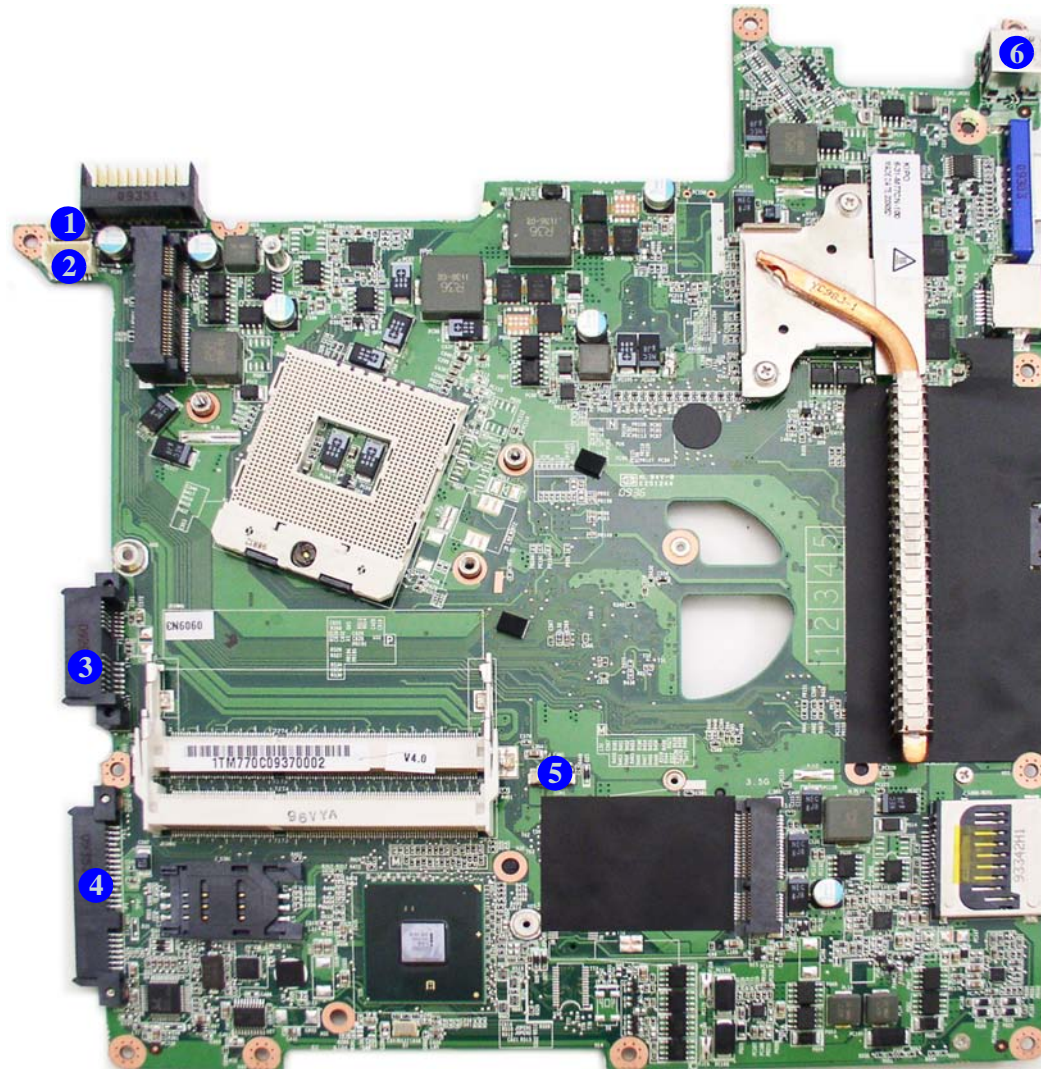

1. BT Cable Connector
2. Multi Board Connector
3. CD-ROM Connector
4. HDD Connector
5. Fan Cable Connector
6. DC-In Jack

Chapter 2: Disassembly

Overview

This chapter provides step-by-step instructions for disassembling the *W760CU[H]/W765CU[H]* series notebook's parts and subsystems. When it comes to reassembly, reverse the procedures (unless otherwise indicated).

We suggest you completely review any procedure before you take the computer apart.

Procedures such as upgrading/replacing the RAM, optical device and hard disk are included in the User's Manual but are repeated here for your convenience.

To make the disassembly process easier each section may have a box in the page margin. Information contained under the figure # will give a synopsis of the sequence of procedures involved in the disassembly procedure. A box with a  lists the relevant parts you will have after the disassembly process is complete. **Note:** The parts listed will be for the disassembly procedure listed ONLY, and not any previous disassembly step(s) required. Refer to the part list for the previous disassembly procedure. The amount of screws you should be left with will be listed here also.

A box with a  will also provide any possible helpful information. A box with a  contains warnings.

An example of these types of boxes are shown in the sidebar.

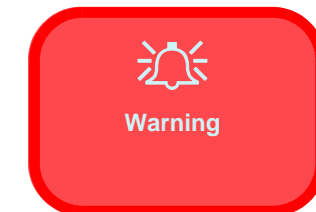
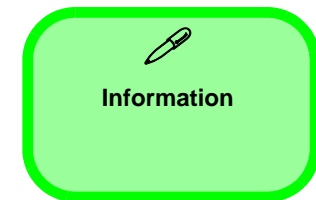

Disassembly

NOTE: All disassembly procedures assume that the system is turned **OFF**, and disconnected from any power supply (the battery is removed too).

Maintenance Tools

The following tools are recommended when working on the notebook PC:

- M3 Philips-head screwdriver
- M2.5 Philips-head screwdriver (magnetized)
- M2 Philips-head screwdriver
- Small flat-head screwdriver
- Pair of needle-nose pliers
- Anti-static wrist-strap

Connections

Connections within the computer are one of four types:

Locking collar sockets for ribbon connectors	To release these connectors, use a small flat-head screwdriver to gently pry the locking collar away from its base. When replacing the connection, make sure the connector is oriented in the same way. The pin1 side is usually not indicated.
Pressure sockets for multi-wire connectors	To release this connector type, grasp it at its head and gently rock it from side to side as you pull it out. Do not pull on the wires themselves. When replacing the connection, do not try to force it. The socket only fits one way.
Pressure sockets for ribbon connectors	To release these connectors, use a small pair of needle-nose pliers to gently lift the connector away from its socket. When replacing the connection, make sure the connector is oriented in the same way. The pin1 side is usually not indicated.
Board-to-board or multi-pin sockets	To separate the boards, gently rock them from side to side as you pull them apart. If the connection is very tight, use a small flat-head screwdriver - use just enough force to start.

Maintenance Precautions

The following precautions are a reminder. To avoid personal injury or damage to the computer while performing a removal and/or replacement job, take the following precautions:

1. **Don't drop it.** Perform your repairs and/or upgrades on a stable surface. If the computer falls, the case and other components could be damaged.
2. **Don't overheat it.** Note the proximity of any heating elements. Keep the computer out of direct sunlight.
3. **Avoid interference.** Note the proximity of any high capacity transformers, electric motors, and other strong magnetic fields. These can hinder proper performance and damage components and/or data. You should also monitor the position of magnetized tools (i.e. screwdrivers).
4. **Keep it dry.** This is an electrical appliance. If water or any other liquid gets into it, the computer could be badly damaged.
5. **Be careful with power.** Avoid accidental shocks, discharges or explosions.
 - Before removing or servicing any part from the computer, turn the computer off and detach any power supplies.
 - When you want to unplug the power cord or any cable/wire, be sure to disconnect it by the plug head. Do not pull on the wire.
6. **Peripherals** – Turn off and detach any peripherals.
7. **Beware of static discharge.** ICs, such as the CPU and main support chips, are vulnerable to static electricity. Before handling any part in the computer, discharge any static electricity inside the computer. When handling a printed circuit board, do not use gloves or other materials which allow static electricity buildup. We suggest that you use an anti-static wrist strap instead.
8. **Beware of corrosion.** As you perform your job, avoid touching any connector leads. Even the cleanest hands produce oils which can attract corrosive elements.
9. **Keep your work environment clean.** Tobacco smoke, dust or other air-borne particulate matter is often attracted to charged surfaces, reducing performance.
10. **Keep track of the components.** When removing or replacing any part, be careful not to leave small parts, such as screws, loose inside the computer.

Cleaning

Do not apply cleaner directly to the computer, use a soft clean cloth.

Do not use volatile (petroleum distillates) or abrasive cleaners on any part of the computer.



Power Safety Warning

Before you undertake any upgrade procedures, make sure that you have turned off the power, and disconnected all peripherals and cables (including telephone lines). It is advisable to also remove your battery in order to prevent accidentally turning the machine on.

Disassembly Steps

The following table lists the disassembly steps, and on which page to find the related information. **PLEASE PERFORM THE DISASSEMBLY STEPS IN THE ORDER INDICATED.**

To remove the Battery:

1. Remove the battery [page 2 - 5](#)

To remove the HDD:

1. Remove the battery [page 2 - 5](#)
2. Remove the HDD [page 2 - 6](#)

To remove the Optical Device:

1. Remove the battery [page 2 - 5](#)
2. Remove the Optical device [page 2 - 8](#)

To remove the System Memory:

1. Remove the battery [page 2 - 5](#)
2. Remove the system memory [page 2 - 9](#)

To remove the Inverter Board:

1. Remove the battery [page 2 - 5](#)
2. Remove the inverter board [page 2 - 11](#)

To remove the Wireless LAN Module:

1. Remove the battery [page 2 - 5](#)
2. Remove the wireless LAN [page 2 - 12](#)

To remove and install a Processor:

1. Remove the battery [page 2 - 5](#)
2. Remove the processor [page 2 - 13](#)
3. Install the processor [page 2 - 15](#)

To remove the Bluetooth Module:

1. Remove the battery [page 2 - 5](#)
2. Remove the Bluetooth [page 2 - 16](#)

To remove the Keyboard:

1. Remove the battery [page 2 - 5](#)
2. Remove the keyboard [page 2 - 17](#)

To remove the Modem:

1. Remove the battery [page 2 - 5](#)
2. Remove the HDD [page 2 - 6](#)
3. Remove the Optical device [page 2 - 8](#)
4. Remove the processor [page 2 - 13](#)
5. Remove the keyboard [page 2 - 17](#)
6. Remove the modem [page 2 - 18](#)

Removing the Battery

1. Turn the computer **off**, and turn it over.
2. Slide the latch **1** in the direction of the arrow.
3. Slide the latch **2** in the direction of the arrow, and hold it in place.
4. Slide the battery **3** in the direction of the arrow **4**.

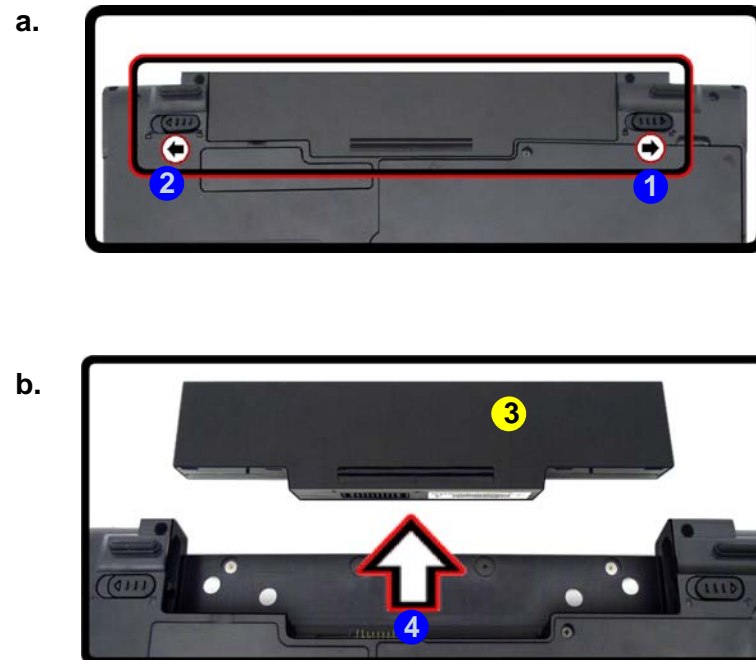
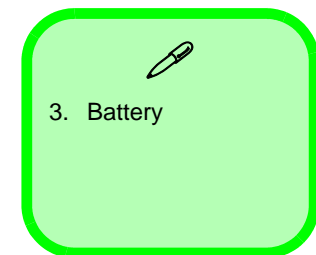

Figure 1
Battery Removal

- a. Slide the latch and hold in place.
- b. Slide the battery in the direction of the arrow.



Removing the Hard Disk Drive

The hard disk drive can be taken out to accommodate other 2.5" serial (SATA) hard disk drives with a height of 9.5mm (h). Follow your operating system's installation instructions, and install all necessary drivers and utilities (as outlined in **Chapter 4 of the User's Manual**) when setting up a new hard disk.

Figure 2
**HDD Assembly
Removal**

Hard Disk Upgrade Process

- a. Locate the HDD bay cover and remove the screw(s).

1. Turn **off** the computer, and remove the battery ([page 2 - 5](#)).
2. Locate the hard disk bay cover and remove screw **1** & **2**.

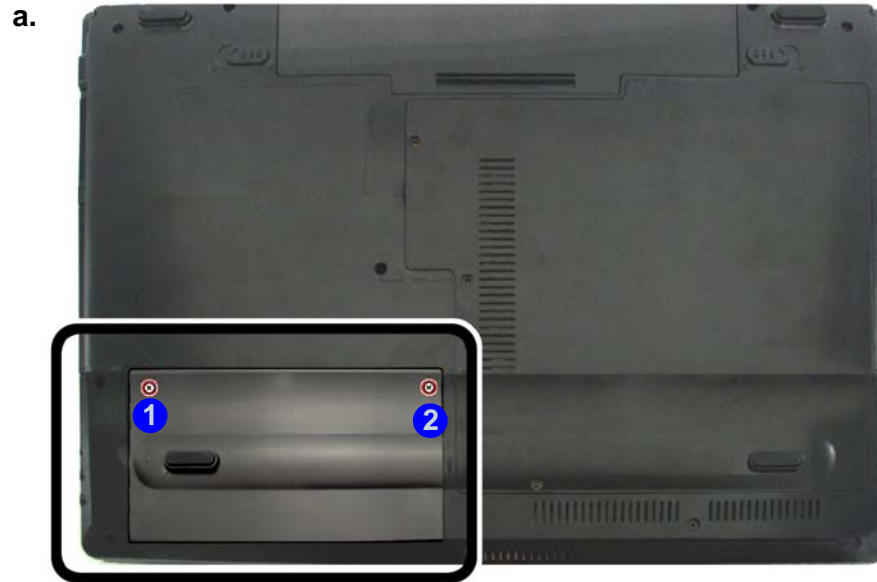

HDD System Warning

New HDD's are blank. Before you begin make sure:

You have backed up any data you want to keep from your old HDD.

You have all the CD-ROMs and FDDs required to install your operating system and programs.

If you have access to the internet, download the latest application and hardware driver updates for the operating system you plan to install. Copy these to a removable medium.



- 2 Screws

3. Remove the hard disk bay cover **3**.
4. Grip the tab and slide the hard disk in the direction of arrow **4**.
5. Lift the hard disk out of the bay **5**.
6. Remove the screw **6** and the adhesive cover **7** from the hard disk **8**.
7. Reverse the process to install a new hard disk (do not forget to replace all the screws and covers).

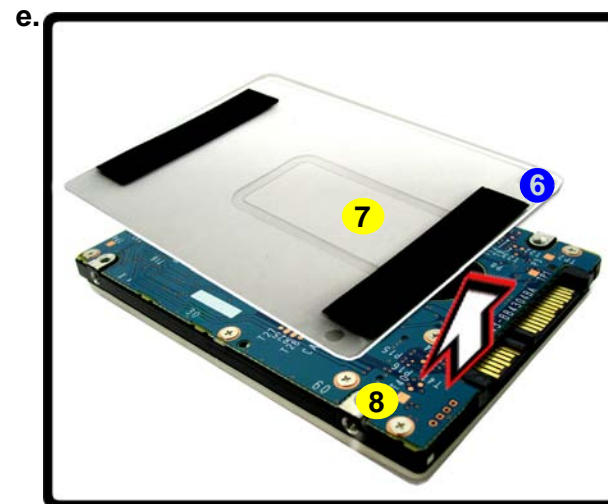
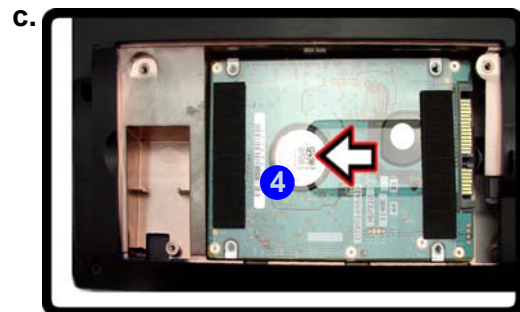

- b. Remove the HDD bay cover.
- c. Grip the tab and slide the HDD in the direction of the arrow.
- d. Lift the HDD assembly out of the bay.
- e. Remove the screws and adhesive cover.



Disassembly

Figure 4
**Optical Device
 Removal**

- Remove the screws.
- Remove the HDD bay cover.
- Remove the screw.
- Push the optical device out off the computer at point 6.

Removing the Optical (CD/DVD) Device

- Turn **off** the computer, and remove the battery ([page 2 - 5](#)).
- Locate the hard disk bay cover and remove screw **1** & **2**.
- Remove the hard disk bay cover **3**.
- Remove the screw at point **4**, and use a screwdriver to carefully push out the optical device **6** at point **5**.
- Insert the new device and carefully slide it into the computer (the device only fits one way. **DO NOT FORCE IT**; The screw holes should line up).
- Restart the computer to allow it to automatically detect the new device.

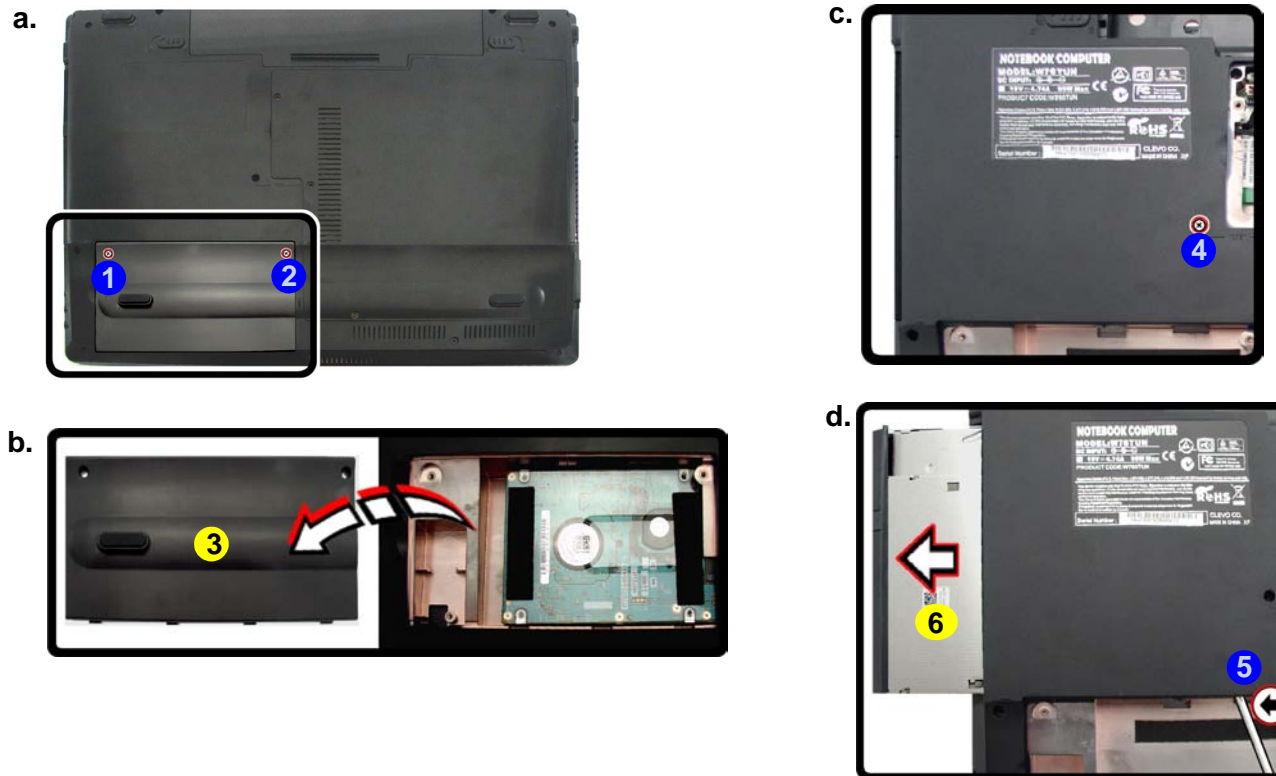

- HDD Bay Cover
- Optical Device

- 3 Screws

Removing the System Memory (RAM)

The computer has two memory sockets for 200 pin Small Outline Dual In-line Memory Modules (SO-DIMM) supporting **DDR3** 1066/1333MHz. The main memory can be expanded up to 8GB. The SO-DIMM modules supported are 1024MB, and 2048MB and **DDRII** Modules. The total memory size is automatically detected by the POST routine once you turn on your computer.

Memory Upgrade Process

1. Turn **off** the computer, remove the battery ([page 2 - 5](#)).
2. Locate the component bay cover **1**, and remove screws **2** - **4**.
3. Carefully (**a fan and cable are attached to the under side of the cover**) lift up the bay cover.
4. Carefully disconnect the fan cable **5**, and remove the cover **1**.

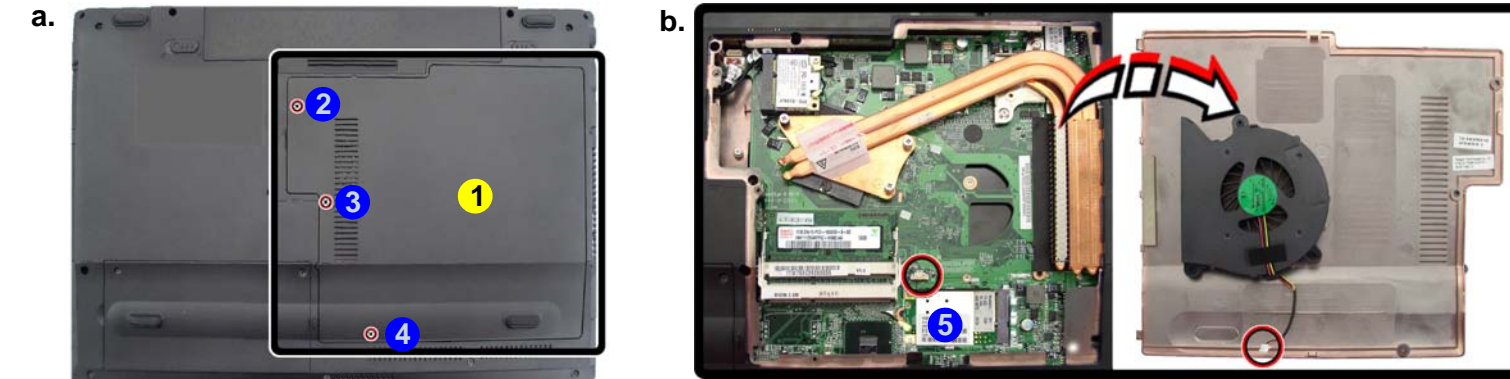

Figure 5
RAM Module Removal

- a. Remove the screws.
- b. Remove the cover.



Contact Warning

Be careful not to touch the metal pins on the module's connecting edge. Even the cleanest hands have oils which can attract particles, and degrade the module's performance.



1. Component Bay Cover
- 3 Screws

Disassembly

Figure 6 RAM Module Removal (cont'd.)

- c. Pull the release latch(es).
d. Remove the module(s).

5. Gently pull the two release latches (6 & 7) on the sides of the memory socket in the direction indicated by the arrows (*Figure 6c*).

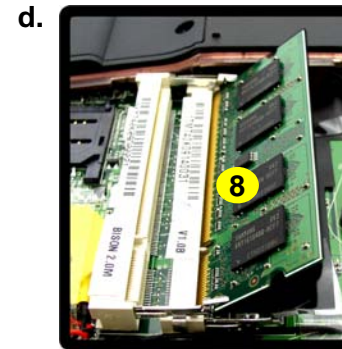
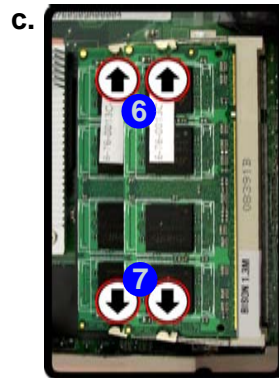

6. The RAM module(s) 8 will pop-up (*Figure 6d*), and you can then remove it.
7. Pull the latches to release the second module if necessary.
8. Insert a new module holding it at about a 30° angle and fit the connectors firmly into the memory slot.
9. The module's pin alignment will allow it to only fit one way. Make sure the module is seated as far into the slot as it will go. **DO NOT FORCE** the module; it should fit without much pressure.
10. Press the module in and down towards the mainboard until the slot levers click into place to secure the module.
11. Replace the bay cover and screws (**make sure you reconnect the fan cable before screwing down the bay cover**).

Note that there are five 9 - 13 cover pins which need to be aligned with slots in the case, to insure a proper cover fit, before screwing down the bay cover 1.

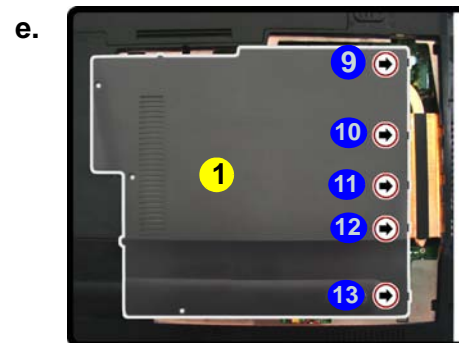

12. Restart the computer to allow the BIOS to register the new memory configuration as it starts up.



8. RAM Module(s)

Removing the Inverter Board

1. Turn **off** the computer, and remove the battery ([page 2 - 5](#)).
2. Remove any rubber covers, screws **1** - **6** ([Figure 7a](#)), then run your finger around the middle of the frame to carefully unsnap the LCD front panel module **7** from the back.
3. Discharge the remaining system power (see [?\\$paratext>?](#) below).
4. Remove screw **8** ([Figure 7b](#)) from the inverter, and carefully lift the inverter board up slightly.
5. Disconnect cables **9** & **10** ([Figure 7c](#)) from the inverter, then remove the inverter **11** ([Figure 7d](#)) from the LCD back cover module.

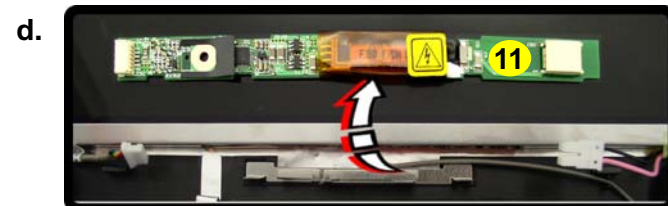
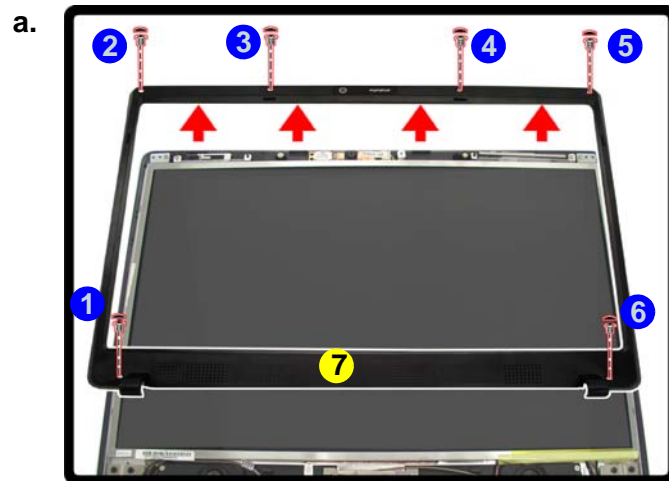



Inverter Power Warning

In order to prevent a short circuit when removing the inverter it is necessary to discharge any remaining system power. To do so, press the computer's power button for a few seconds before disconnecting the inverter cable.



7. LCD Front Panel
11. Inverter Board

- 6 Screws

Figure 7
Inverter Board Removal

- a. Remove the 6 screws and unsnap the LCD front panel module from the back.
- b. Remove the screw and discharge the remaining power from the inverter board and lift the board up slightly.
- c. Disconnect the cables from the inverter.
- d. Remove the inverter.

Disassembly

Figure 8
**Wireless LAN
Module Removal**

- Remove the cover.
- Disconnect the cables and remove the screw.
- The WLAN module will pop up.
- Lift the WLAN module out.

Removing the Wireless LAN Module

- Turn off the computer, remove the battery ([page 2 - 5](#)) and the component bay cover ([page 2 - 9](#)).
- The Wireless LAN module will be visible at point ① on the mainboard.
- Carefully disconnect cables ② - ③, then remove screw ④ from the module socket.
- The Wireless LAN module ⑤ will pop-up.
- Lift the Wireless LAN module ([Figure 12d](#)) up and off the computer.

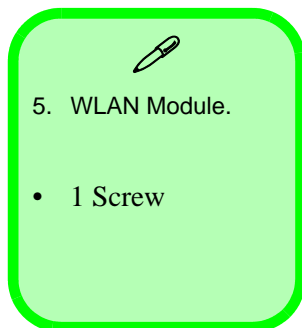
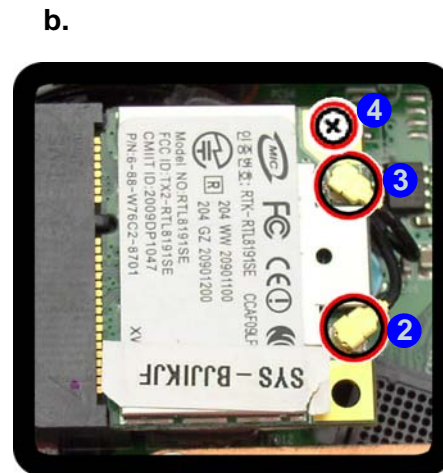
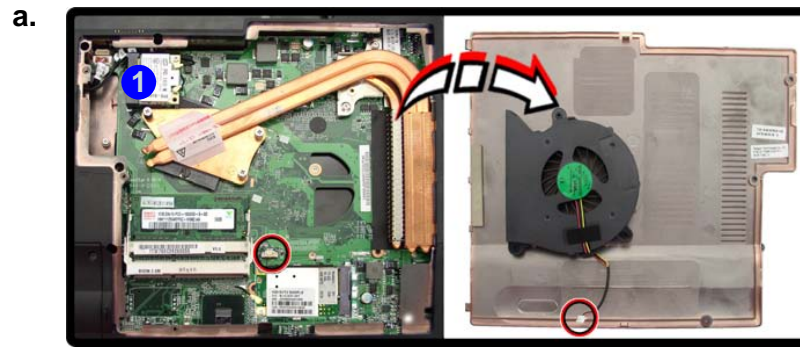

Removing and Installing the Processor

Processor Removal Procedure

1. Turn **off** the computer, remove the battery ([page 2 - 5](#)), the component bay cover ([page 2 - 9](#)) and the WLAN module ([page 2 - 12](#)).
2. Loosen the CPU heat sink screws in the order **3**, **2** & **1** (the reverse order as indicated on the label).
3. Carefully lift up the heat sink **4** ([Figure 9c](#)) off the computer.

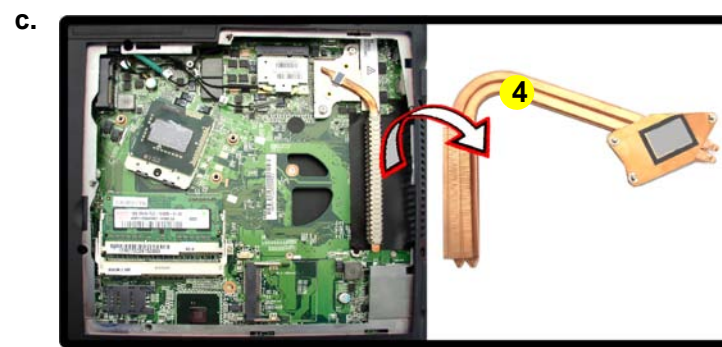
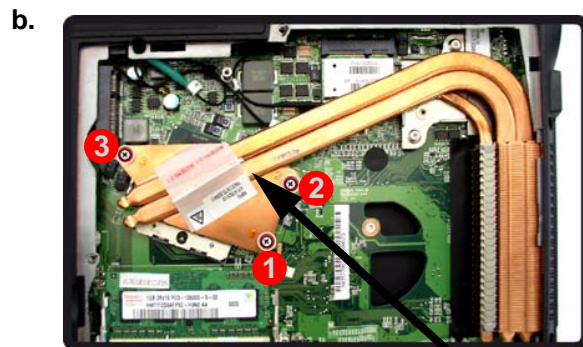
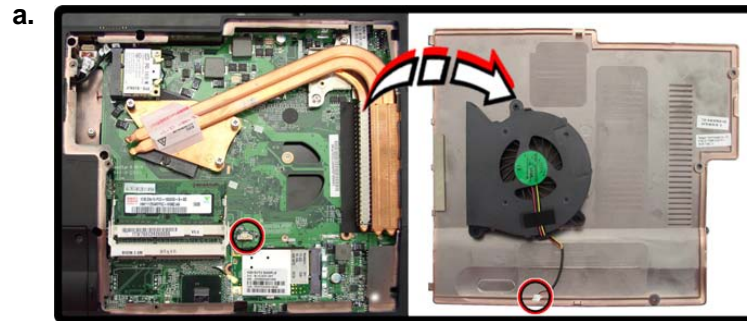

Note: Loosen the screws in the reverse order 3, 2, 1 as indicated on the label.

Figure 9
Processor Removal

- a. Remove the cover and locate the heat sink.
- b. Loosen the screws in the order indicated.
- c. Remove the heat sink.

CPU Warning

In order to prevent damaging the contact pins when removing the CPU, it is necessary to first remove the WLAN module from the computer.



4. Heat Sink

- 3 Screws

Disassembly

Figure 10 Processor Removal (cont'd)

- d. Turn the release latch to unlock the CPU.
- e. Lift the CPU out of the socket.

4. Turn the release latch **6** towards the unlock symbol , to release the CPU (*Figure 10a*).
5. Carefully (it may be hot) lift the CPU **7** up out of the socket (*Figure 10b*).
6. See [page 2 - 15](#) for information on inserting a new CPU.
7. When re-inserting the CPU, pay careful attention to the pin alignment, it will fit only one way (DO NOT FORCE IT!).

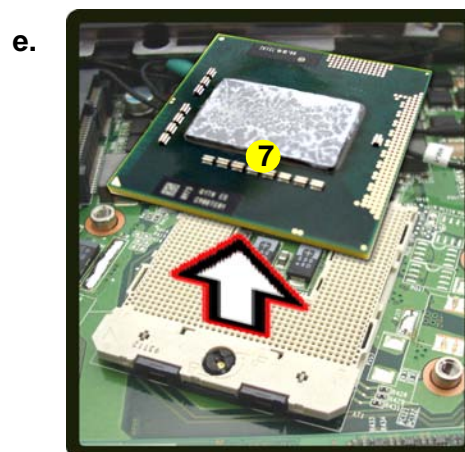
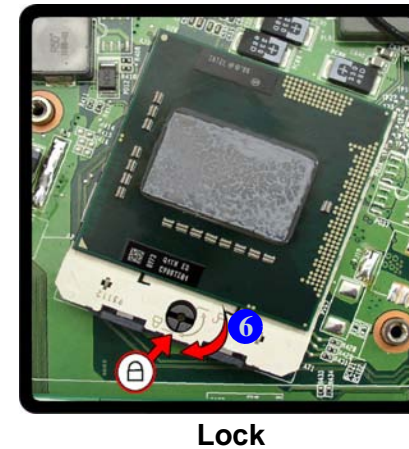
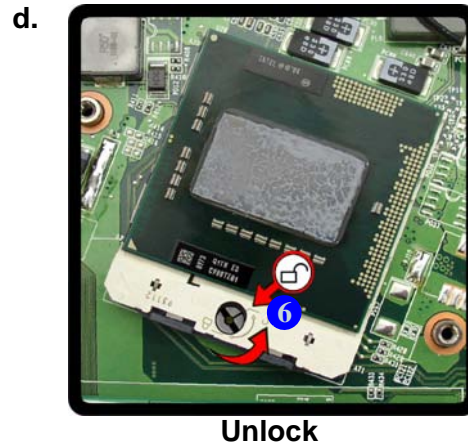

Caution

The heat sink, and CPU area in general, contains parts which are subject to high temperatures. Allow the area time to cool before removing these parts.

7. CPU

Processor Installation Procedure

1. Insert the CPU **A**, pay careful attention to the pin alignment, it will fit only one way (DO NOT FORCE IT!), and turn the release latch **B** towards the lock symbol  (*Figure 11b*).
2. **Remove the sticker **C**** (*Figure 11c*) from the heat sink.
3. Insert the heat sink **D** as indicated in *Figure 11c*.
4. Tighten the CPU heat sink screws in the order **1**, **2** & **3** (the order as indicated on the label and *Figure 11d*).
5. Replace the component bay cover and tighten the screws (*page 2 - 12*).

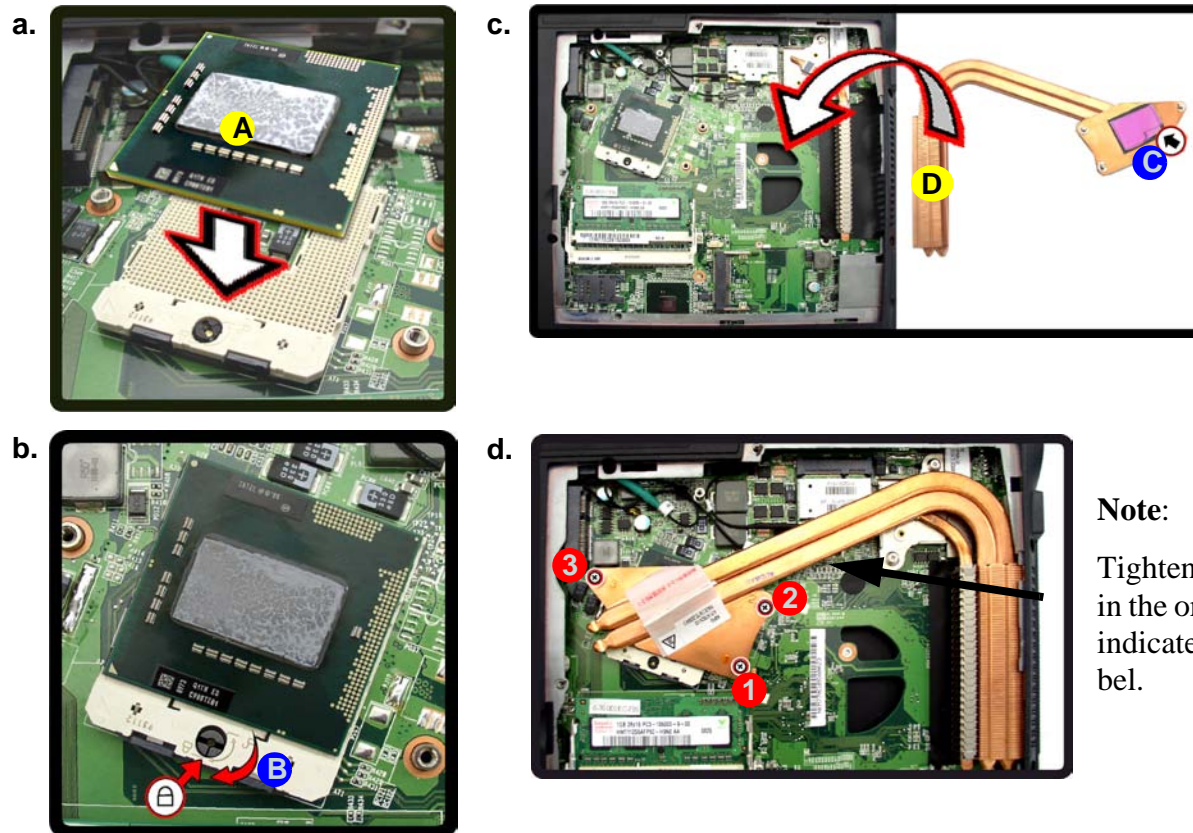

Note:

Tighten the screws in the order 1, 2, 3 as indicated on the label.



A. CPU
D. Heat Sink

- 3 Screws

Figure 11
Processor Installation

- a. Insert the CPU.
- b. Turn the release latch towards the lock symbol.
- c. Remove the sticker from the heat sink and insert the heat sink.
- d. Tighten the screws.

Disassembly

Figure 12
**Bluetooth Module
 Removal**

Removing the Bluetooth Module

1. Turn **off** the computer, remove the battery ([page 2 - 5](#)) and the component bay cover ([page 2 - 9](#)).
 2. The Bluetooth will be visible at point **1** on the mainboard.
 3. Remove the screw **2** and turn the module over.
 4. Carefully separate the Bluetooth module from the connector **3** and disconnect the cable **4**.
 5. Lift the Bluetooth module **5** ([Figure 12d](#)) up and off the computer.
- a. Remove the cover and locate the Bluetooth.
 - b. Remove the screw.
 - c. Disconnect the cable and the connector.
 - d. Lift the Bluetooth module up off the socket.

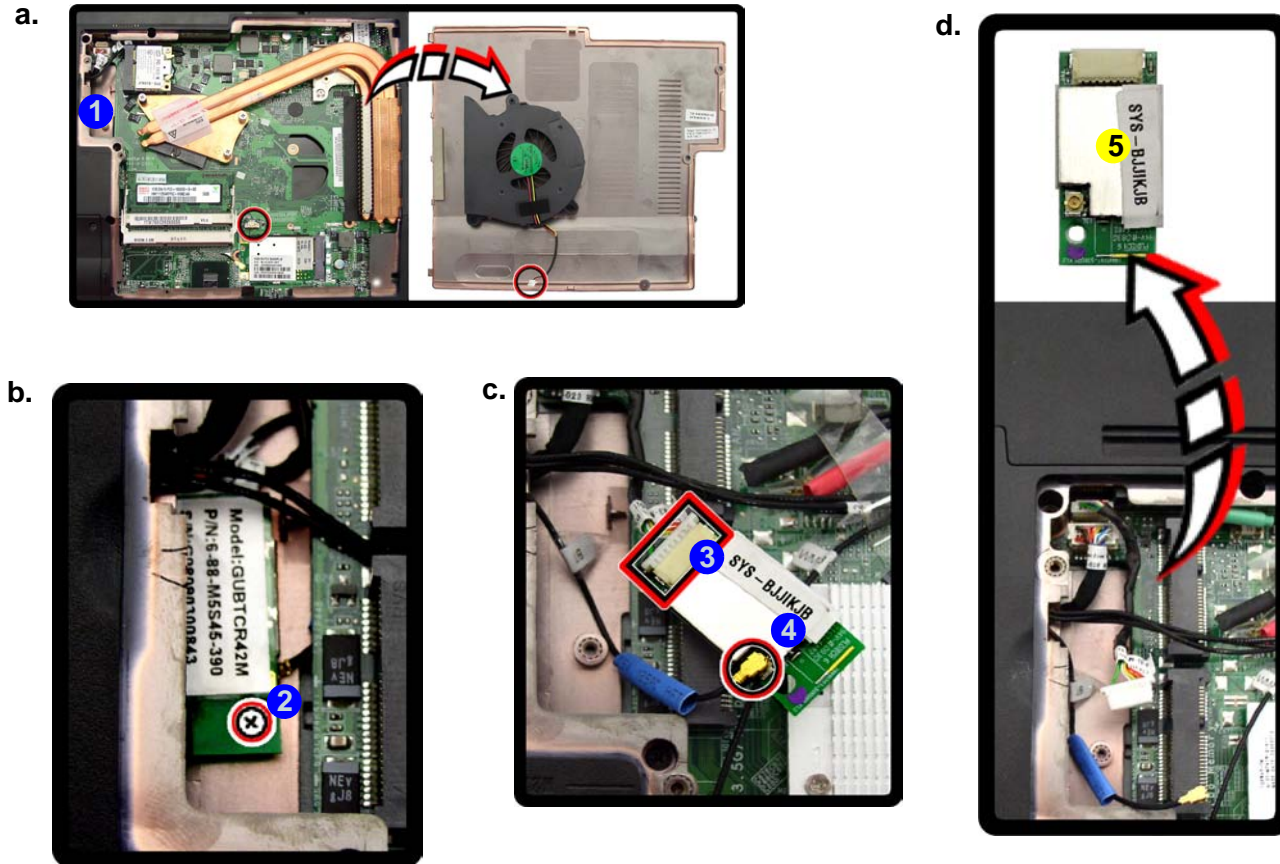

5. Bluetooth Module

- 1 Screw

Removing the Keyboard

1. Turn **off** the computer.
2. Remove the battery **1** ([page 2 - 5](#)).
3. Remove the screws **2** - **3** and use a screwdriver to carefully push out the top cover module **5** at point **4**.
4. Remove the top cover module **5** and the screws **6** - **10** ([Figure 13d](#)),
5. Carefully lift the keyboard **11** up, being careful not to bend the keyboard ribbon cable ([Figure 13e](#)).
6. Disconnect the keyboard ribbon cable **12** from the locking collar socket **13**.
7. Carefully lift up the keyboard ([Figure 13f](#)) off the computer.

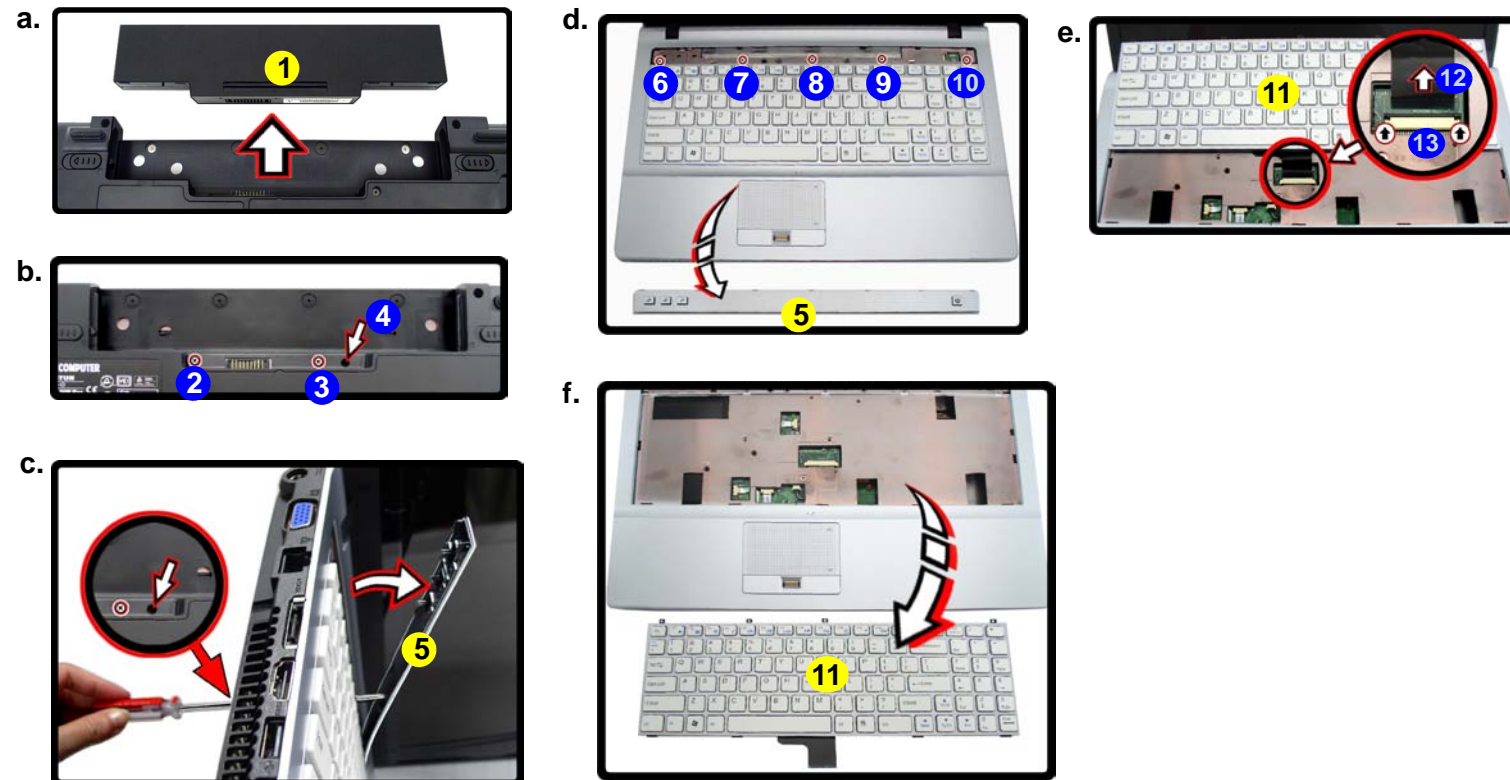
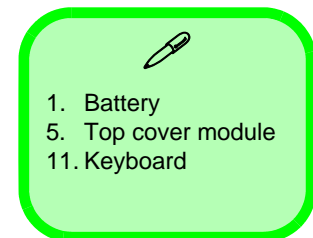

Figure 13
Keyboard Removal

- a. Remove the battery.
- b. Remove the screws and use a screwdriver to carefully push out the top cover module at point **4**.
- c. Remove the Top cover module.
- d. Remove the screws.
- e. Lift the keyboard up and disconnect the cable from the locking collar.
- f. Remove the keyboard.



Disassembly

Removing the Modem

Figure 14

Modem Removal

- a. Remove the screws.
 - b. Turn the computer over, remove the screws and disconnect the cable.
1. Turn **off** the computer, remove the battery ([page 2 - 5](#)), HDD ([page 2 - 6](#)), component bay cover ([page 2 - 9](#)), optical device ([page 2 - 8](#)), CPU ([page 2 - 12](#)), bluetooth ([page 2 - 16](#)) and keyboard ([page 2 - 17](#)).
 2. Remove screws ① - ②① from the bottom case.
 3. Turn the computer over, remove screw ②② and disconnect cables ②③ - ②⑥ ([Figure 14b](#)).

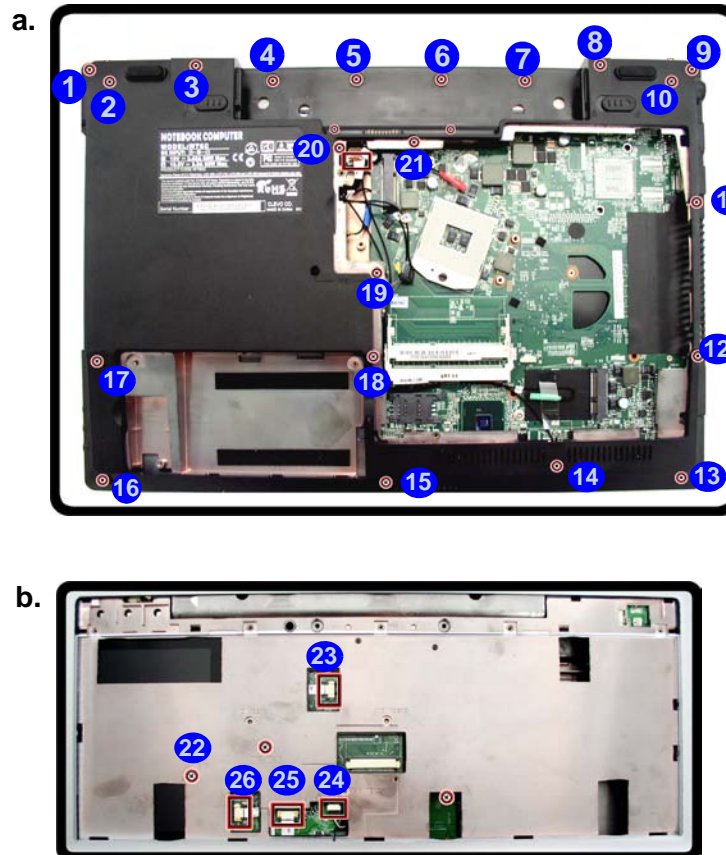

- 23 Screws

- Carefully lift the top case **29** up and off the computer (*Figure 15c*).
- Remove screw **30** from the module and disconnect cable (*Figure 15c*).
- Carefully lift the modem **31** up and off the socket (*Figure 15d*).

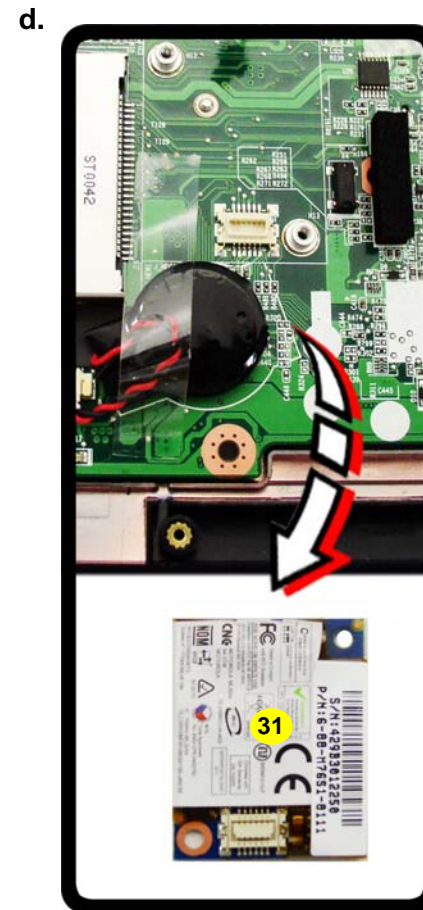
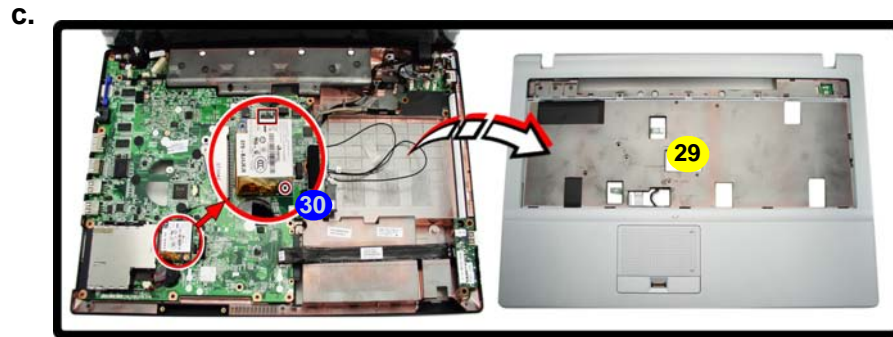

Figure 15
Modem Removal
(cont'd.)

- Lift the top case off the computer.
- Remove screw and disconnect cable.
- Lift the modem off the socket.



29. Top Case
31. Modem

- 1 Screw

Appendix A: Part Lists

This appendix breaks down the *W760CU[H]/W765CU[H]* series notebook's construction into a series of illustrations. The component part numbers are indicated in the tables opposite the drawings.

Note: This section indicates the *manufacturer's* part numbers. Your organization may use a different system, so be sure to cross-check any relevant documentation.

Note: Some assemblies may have parts in common (especially screws). However, the part lists DO NOT indicate the total number of duplicated parts used.

Note: Be sure to check any update notices. The parts shown in these illustrations are appropriate for the system at the time of publication. Over the product life, some parts may be improved or re-configured, resulting in *new* part numbers.

Part List Illustration Location

The following table indicates where to find the appropriate part list illustration.

Table A- 1
**Part List Illustration
Location**

Parts	W760CU[H]	W765CU[H]
Top with Fingerprint	<i>page A - 3</i>	<i>page A - 4</i>
Top without Fingerprint	<i>page A - 5</i>	<i>page A - 6</i>
Bottom	<i>page A - 7</i>	
LCD	<i>page A - 8</i>	
COMBO	<i>page A - 9</i>	
DVD-Dual Drive	<i>page A - 10</i>	

Top with Fingerprint (W760CU[H])

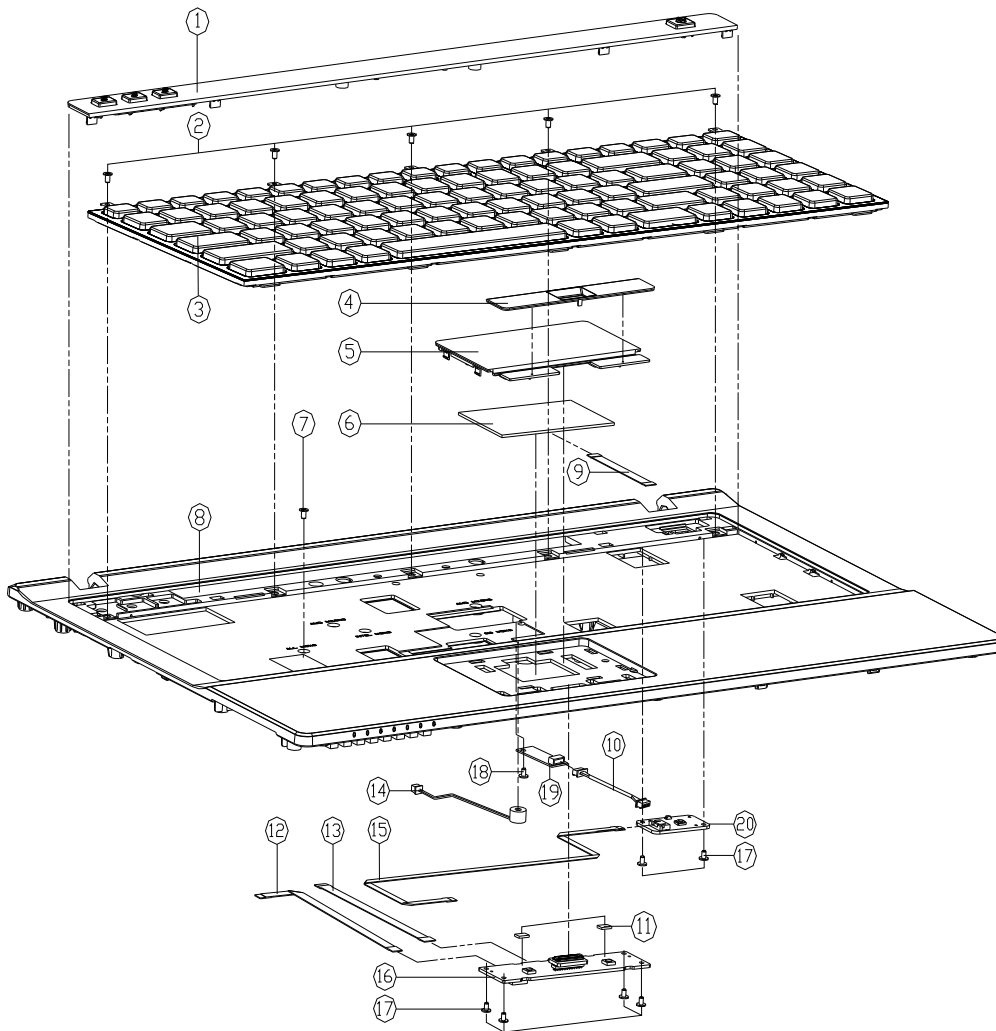

Figure A - 1
Top with
Fingerprint
(W760CU[H])

ITEM	PART NAME	PART NO	REMARK
1	TOP COVER MODULE W760S	6-42-W76S2-801	
2	SOCKEY NEXSL KI BKZ KI1 NEX3S I+3	6-35-B6120-2R3	
3	CLICK BUTTON COVER FP MODULE W760S	6-79-W76S00K-010	
4	CLICK BUTTON COVER FP MODULE W760S	6-42-W76S2-700	
5	CLICK BUTTON PLATE KEYS CASE ORIGIN W760S	6-42-W76S2-012	
6	TOUCH PAD TM-00398-003 W840T	6-49-W84T2-020	
7	SOCKEY NEXSL KI BKZ KI1 N1 00-W4S3I+0	6-35-B6120-3RD	
8	TOP CASE MODULE W760S	6-39-W76S2-014	
8	TOP CASE MODULE W760S-C	6-39-W76S2-014-C	
9	FPC CABLE FOR CLICK BOARD TO TOUCH PAD SWM SWM FOR W760S	6-43-M76S0-041	
10	FPC CABLE SWM SWM TO SWM BOARD W760S SWM SWM FOR W760S	6-43-M76S0-011	(OPTION)
11	GASKET (5X34) FOR TOP CASE W760S	6-47-00190-05K	
12	FPC CABLE FOR W76 TO FINGERPRINT SWM SWM FOR W760S	6-43-W76SF-010-1	
13	FPC CABLE SWM SWM TO CLICK BOARD FOR W760S	6-43-W76S0-020-1	
14	MC 04035 2X3V 228 W760S 04035-FIL-01620C	6-23-EM62E-010-2	
15	FPC CABLE FOR W76 TO SWM BOARD W760S SWM SWM FOR W760S	6-43-W76S0-010-1	
16	CLICK BOARD (A) OPTICAL FINGERPRINT BOARD FOR W760S	6-77-M77CA-N01	
17	W760S SOCKEY NEXSL KI BKZ KI1 N1 00-GTY-PATCH	6-35-B1120-3RE	
18	W760S SOCKEY NEXSL KI BKZ KI1 N1 00-GTY-PATCH	6-35-B1120-3RD	
19	KEYBOARD W760S W760S W760S W760S W760S W760S	6-88-M7315-3901	(OPTION)
19	KEYBOARD W760S W760S W760S W760S W760S W760S	6-88-M7315-3901	(OPTION)
19	KEYBOARD W760S W760S W760S W760S W760S W760S	6-88-M7315-3901	(OPTION)
19	KEYBOARD W760S W760S W760S W760S W760S W760S	6-88-M7315-3901	(OPTION)
20	POWER SWITCH BOARD V30 W740S	6-77-M74SS-D03	

A.Part Lists

Top with Fingerprint (W765CU[H])

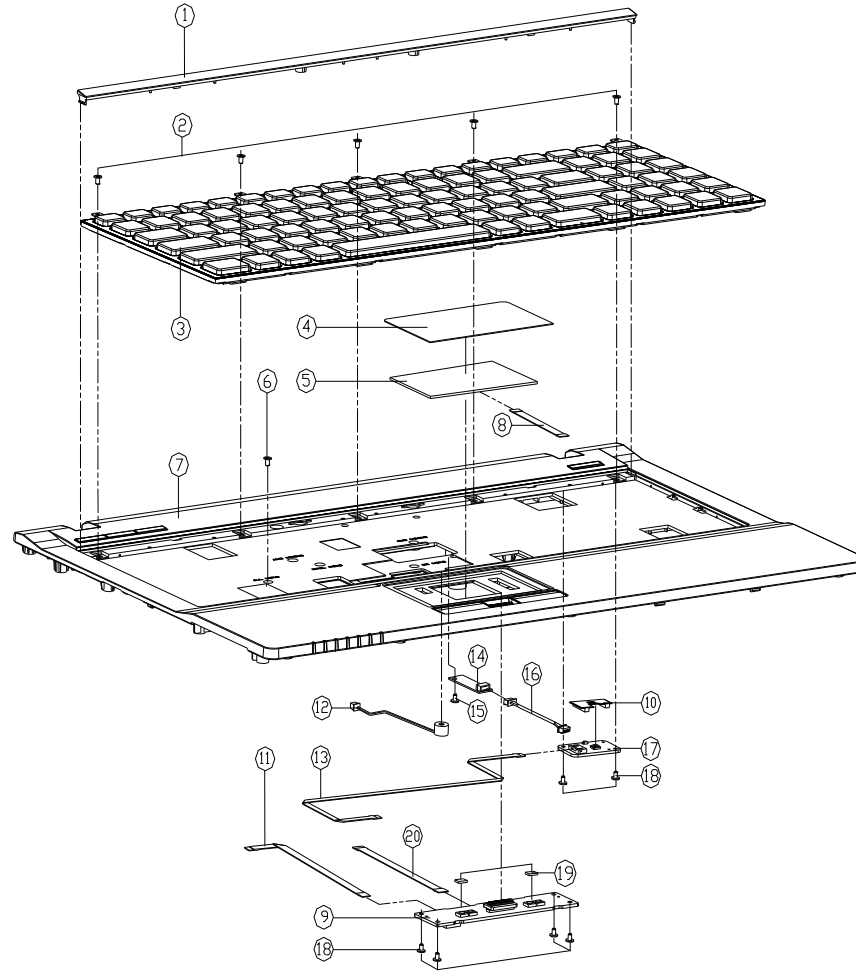

Figure A - 2
Top with
Fingerprint
(W765CU[H])

ITEM	PART NAME	PART NO	REMARK
1	TOP COVER FC-MS GRAY ORN (W765CU[H])	6-42-W7652-080	
2	SCREW HEX-FLX M2.2 X1.4 (W765CU[H])	6-35-B6120-2RB	
3	KEY USA (W765CU[H])	6-79-W765500-010	
4	W/LAR FOR TOUCH PAD W765CU[H]	6-40-W7652-021	
5	TOUCH PAD TM-00398-003 W765CU[H]	6-49-W8412-020	
6	SCREW HEX-FLX M2.2 X1.4 (W765CU[H])	6-35-B6120-3RD	
7	TOP CASE MIDDLE WITH FINGERPRINT (W765CU[H])	6-39-W7652-014	
8	TOP CASE FOR FINGERPRINT (W765CU[H])	6-43-W7652-041	
9	TOP CASE FOR FINGERPRINT (W765CU[H])	6-77-M77CA-N01	
10	AL FOIL W/LAR FOR POWER W765CU[H]	6-40-W7652-050	
11	TOP CASE FOR FINGERPRINT (W765CU[H])	6-43-W7652-010-1	
12	TOP CASE FOR FINGERPRINT (W765CU[H])	6-23-EM62C-010-2	
13	TOP CASE FOR FINGERPRINT (W765CU[H])	6-43-W7652-010-1	
14	TOP CASE FOR FINGERPRINT (W765CU[H])	6-88-M7315-3901	(OPT ION)
15	TOP CASE FOR FINGERPRINT (W765CU[H])	6-88-M7315-5300	(OPT ION)
16	TOP CASE FOR FINGERPRINT (W765CU[H])	6-35-B1120-3RD	
17	POWER SWITCH BEHND V30 W765CU[H]	6-43-W7652-011	(OPT ION)
18	POWER SWITCH BEHND V30 W765CU[H]	6-77-M745S-003	
19	POWER SWITCH BEHND V30 W765CU[H]	6-35-B1120-3RD	
20	GASKET (S) FOR TOP CASE W765CU[H]	6-47-00190-05K	
21	TOP CASE FOR FINGERPRINT (W765CU[H])	6-43-W7652-020-1	

Top without Fingerprint (W760CU[H])

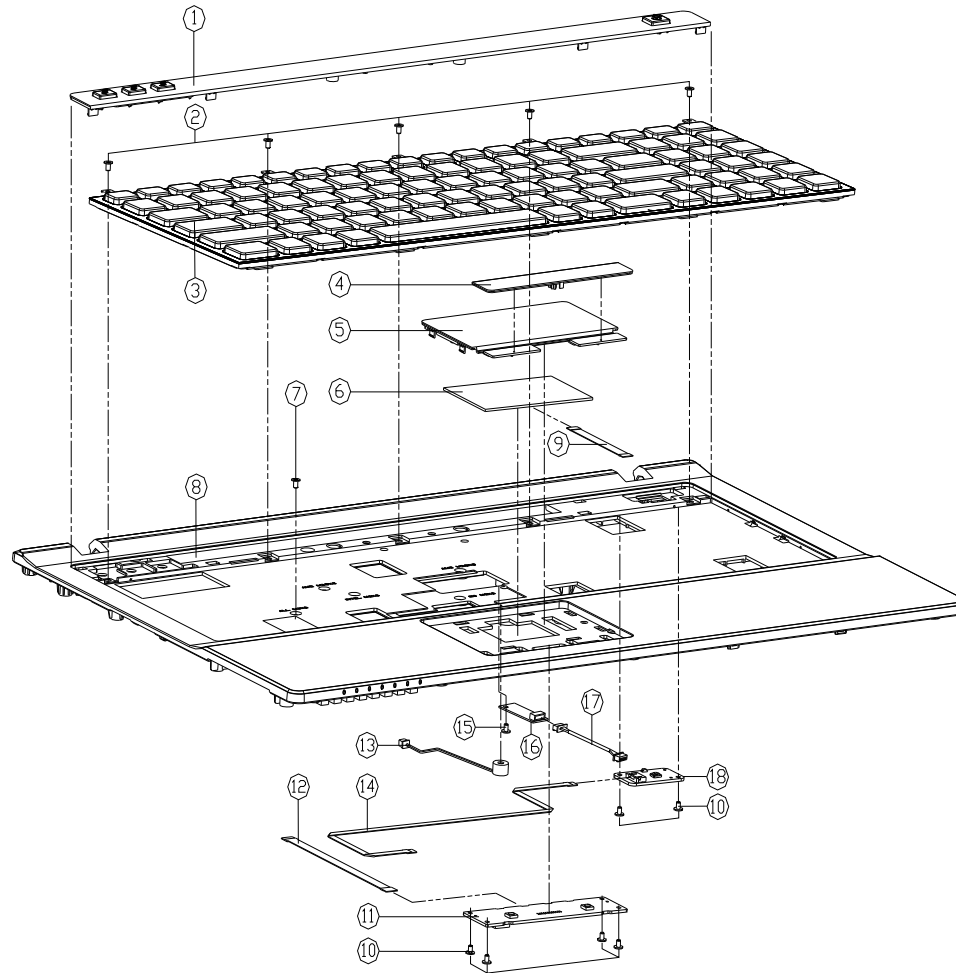

Figure A - 3
Top without
Fingerprint
(W760CU[H])

ITEM	PART NAME	PART NO	REMARK
1	TOP COVER MODULE W760S	6-42-W76S2-801	
2	SOKEY KEYBL KIT BR/Z KIT W76S T403	6-35-B6120-2RB	
3	TOP COVER KEY BL BR/Z KIT W76S T403	6-79-W76S00K-010	
4	CLICK BUTTON COVER VIO FP MODULE W76S	6-42-W76S2-200	
5	CLICK BUTTON PLATE PINKS GRAYE CRATE W76S	6-42-W76S2-012	
6	TOUCH PAD TM-00390-003 W840T	6-49-W84T2-020	
7	SOKEY KEYBL KIT BR/Z KIT W76S W76S T403	6-35-B6120-3RD	
8	TOP CASE MODULE W760S	6-39-W76S2-014	
9	TOP COVER KEY BL BR/Z KIT W76S W76S T403	6-43-W76S0-041	
10	SOKEY KEYBL KIT BR/Z KIT W76S W76S T403	6-35-B1120-3RE	
11	CLICK BOARD VIO QV/D FP W760CU	6-77-W77C2-D01-1	
12	FFC CABLE EPIN WIO TO CLICK BOARD FOR W76S	6-43-W76S0-020-1	
13	FFC CABLE EPIN WIO TO CLICK BOARD FOR W76S	6-23-EM62E-010-2	
14	FFC CABLE WIO TO TOUCH PAD FOR W76S	6-43-W76S0-010-1	
15	SOKEY KEYBL KIT BR/Z KIT W76S W76S T403	6-35-B1120-3RD	
16	OPTIONAL KEYBL KIT BR/Z KIT W76S W76S T403	6-88-W731S-3901	(OPTION)
16	OPTIONAL KEYBL KIT BR/Z KIT W76S W76S T403	6-88-W731S-5300	(OPTION)
17	FFC CABLE WIO TO TOUCH PAD FOR W76S	6-43-W76S0-011	(OPTION)
18	POWER SWITCH BOARD V30 W740S	6-77-W74SS-D03	

A.Part Lists

Top without Fingerprint (W765CU[H])

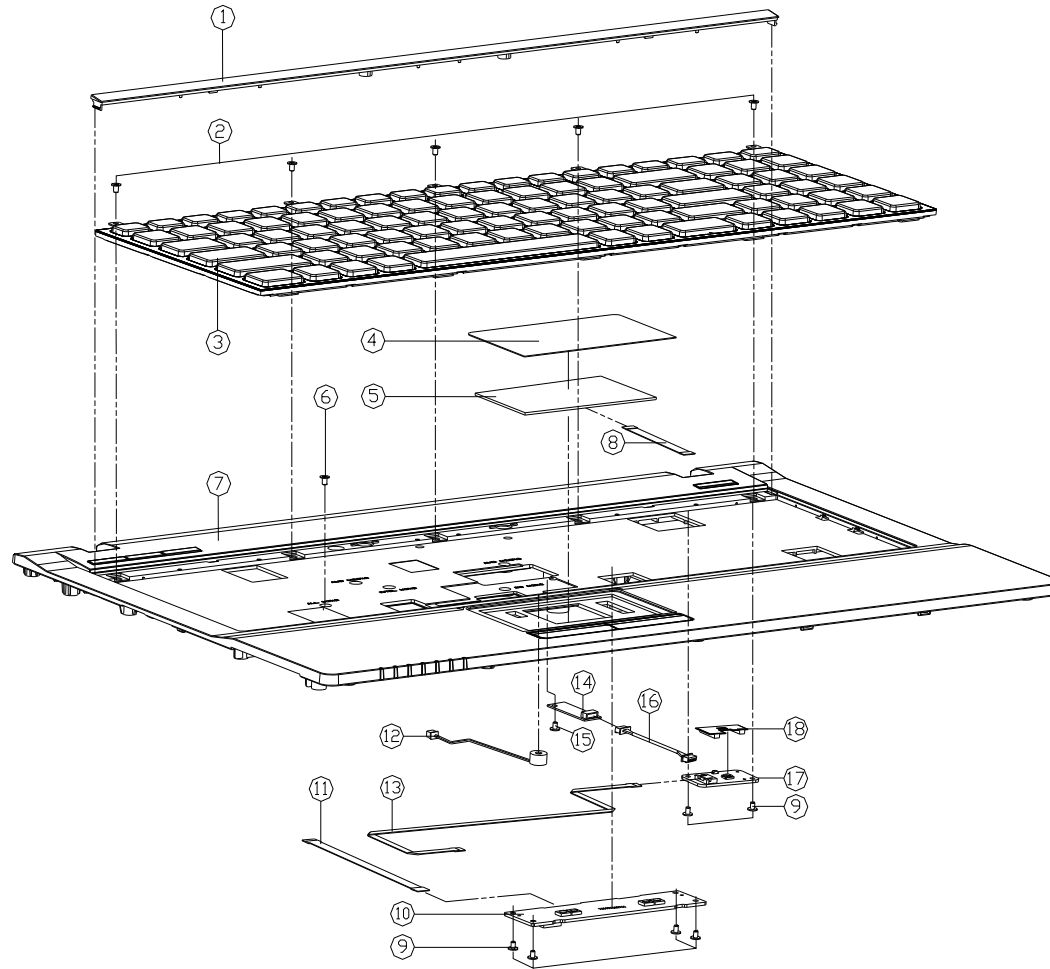
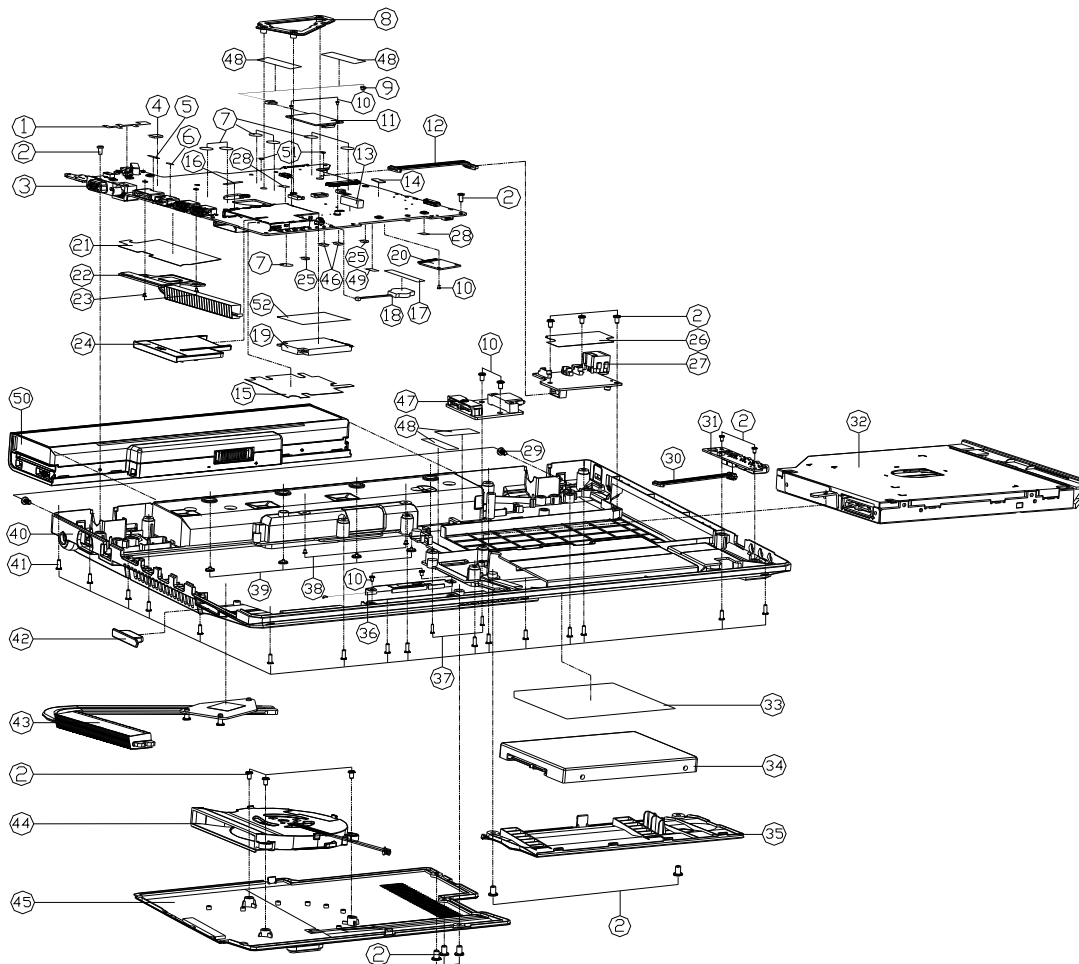

Figure A - 4
Top without
Fingerprint
(W765CU[H])

ITEM	PART NAME	PART NO	REMARK
1	TOP COVER PCABS GAINC CLEAR THINWASS (PH) (6)	6-42-W7652-080	
2	SCREY NEX26L KI BK/2 ICT NEX25 T-103 (PH) (6)	6-35-B6120-2RB	
3	K/B USA INT CLAL FRAMC QSD MIDDLE W/RESOF (PH) (6)	6-79-W765500K-010	
4	MYLAR FOR TOUCH PAD HP200 W765S (PH) (6)	6-40-W7652-021	
5	TOUCH PAD TM-00398-003 W840T (PH) (6)	6-49-W8412-020	
6	SCREY NEX2L KI BZ ICT NY QSD-W45,0T-B40 (PH) (6)	6-35-B6120-3RD	
7	TOP CASE MIDDLE Q/W/D FINGERPRINT (PH) (6)	6-39-W7652-024	
7	TOP CASE MIDDLE Q/W/D FINGERPRINT (PH) (6)	6-39-W7652-024-M	
8	ETC CABLE FOR CLICK BOARD TO TOUCH PAD (PH) (6)	6-43-M7650-041	
9	AL FRAMC FOR SCREY NEX2L KI KI ICT QTY-PATCH (PH) (6)	6-35-B1120-3RE	
10	CLICK BOARD V10 Q/W/D FP M770CU (PH) (6)	6-77-M770C-D01-1	
11	ETC CABLE 6PIN M2 TO CLICK BOARD FOR W765 (PH) (6)	6-43-W7650-020-1	
12	AL QSDMS 2V-2W 22K V-CABLE QSDMS-FIL-00 ALQ (PH) (6)	6-23-EM62E-010-2	
13	ETC CABLE FOR NY TO TOUCH PAD (PH) (6)	6-43-W7650-010-1	
14	AL FRAMC FOR NY TO TOUCH PAD (PH) (6)	6-88-M7315-3901	(CDPT IDN)
14	AL FRAMC FOR NY TO TOUCH PAD (PH) (6)	6-88-M7705-5300	(CDPT IDN)
15	AL FRAMC FOR SCREY NEX2L KI KI ICT QTY-PATCH (PH) (6)	6-35-B1120-3RD	
16	ETC CABLE 4PIN NY TO TOUCH PAD (PH) (6)	6-43-M765B-011	(CDPT IDN)
17	POWER SWITCH BOARD V30 M740S (PH) (6)	6-77-M745S-D03	
18	AL FDL MYLAR FOR POWER W765S (PH) (6)	6-40-W7652-050	

Bottom



ITEM	PART NAME	PART NO	REMARK
1	MYLAR FOR MB STRIP/ENDG. FOR NY	6-40-M74TS-021	
2	SCREW M2*4L KI BK/Z ICT NY	6-35-B612S-5RA	
3	MAIN BOARD V48 V336 V196 W760U	6-77-W76CU-104-BU	
3	MAIN BOARD V48 V476 367196 W760CU	6-77-W76CS-104-1U	
3	MAIN BOARD V48 V476 367196 W760CU	6-77-W76CS-104-1U	
3	MAIN BOARD V48 V476 367196 W760CU	6-77-W76CH-104-U	
3	MAIN BOARD V48 V476 V196 W760CU	6-77-W76CH-104-U	
4	MB TOP RUBBER SILICONE M740T	6-47-M74TS-030	
5	[STAT] FOR MB M740T	6-47-M74TS-010	
6	HOLE FOR MB M740T	6-47-M74TS-020	
7	MYLAR D10 FRB3 M760S	6-40-M76S0-010	
8	CPU SUPPORT BRACKET SECC M770CU	6-33-M77CS-010	
9	WIRE CABLE SPIN MULTI BOARD TO MIC MODULE	6-43-W76CU-010	
10	ALUMINUM SCREW REV. 0.4 ICT CP-PROD (S-AL) 3.0	6-35-B1120-3RD	
11	TOP LABEL (L) 3.0	6-88-L39T1-5301	(OPTION)
11	TOP LABEL (R) 3.0	6-88-M76S1-8111	(OPTION)
11	TOP LABEL (L) 3.0	6-88-M76S1-5300	(OPTION)
12	WIRE CABLE FOR MB TO MULTI BOARD FROM UP W770U	6-43-M7700-020	
13	FOAM PAD SPONGE 60*64*4 CR W760S	6-47-0019A-20A	
14	MIC MYLAR(FR3)+TERACAKA750F1 M740S	6-40-M74SS-031	
15	NEW CARD MYLAR FRB3 KI NI 5000 M740T	6-40-M74T3-011	
16	TAPE MYLAR (C) MYLAR M550J	6-47-M76TS-010	
17	TAPE MYLAR (C) MYLAR M550J	6-40-M55J2-010	
18	ALUMINUM SCREW REV. 0.4 ICT CP-PROD (S-AL) 3.0	6-23-2201S-P2C	
19	ALUMINUM SCREW REV. 0.4 ICT CP-PROD (S-AL) 3.0	6-88-M610W-8800	(OPTION)
20	ALUMINUM SCREW REV. 0.4 ICT CP-PROD (S-AL) 3.0	6-88-W76C2-7000	(OPTION)
20	ALUMINUM SCREW REV. 0.4 ICT CP-PROD (S-AL) 3.0	6-88-W76C2-8700	(OPTION)
20	ALUMINUM SCREW REV. 0.4 ICT CP-PROD (S-AL) 3.0	6-88-W7352-4200	(OPTION)
20	ALUMINUM SCREW REV. 0.4 ICT CP-PROD (S-AL) 3.0	6-88-M3102-7001	(OPTION)
21	HEAT SINK MYLAR FRB3 KI NI 5000 M740S	6-40-M74SM-013	
22	VGA THERMAL MODULE W770CU	6-31-M77CN-100	
23	SCREW M2*4L KI NI ICT NY	6-35-B1120-3RA	
24	ALUMINUM NEW CARD PCBARS T120R	6-42-T12R3-011	
25	CPU COVER SUPPORT RUBBER 60*64*4 SILICONE W760S	6-47-W76CS-010	
26	MIC MYLAR FRB3 KI NI 5000 M740S	6-40-M74SU-011	
27	MULTI I/O BOARD V30 M770CU	6-77-M77C1-D03	
28	PROTECT MB MYLAR FRB3 M740S	6-40-M74SS-020	
29	SCREW M2*4L KI BZ ICT NY	6-35-B6120-4RA	
30	WIRE CABLE SPIN MULTI BOARD FROM UP W760S	6-43-M76S0-052	
31	PHONE JACK & USB BOARD V30A M710U	6-77-M77CA-D03A	
32	SATA BLU-RAY COMBO ASSY (OPTION) W760S	6-79-W760CUW-010	
32	SATA DVD SUPER MULTI ASSY (OPTION) W760S	6-79-M76T000-000	
32	SATA DVD SUPER MULTI ASSY (OPTION) W760S	6-79-W76S000-020	
33	PRODUCT LABEL W760CU	6-45-W760CU03-012	
33	PRODUCT LABEL W760CU	6-45-W76S0003-012	
33	PRODUCT LABEL (FRONT) (OPTION) W760S	6-45-W76S0003-490	
33	PRODUCT LABEL W761CUW3	6-45-W761CUW3-010	
34	W/O HDD ASSY W760S	6-79-W76S000-J010	
35	HDD COVER MODULE W760S	6-42-W76S-J102	
36	ANTENNA W760S 240/320/350 PIFA W/O 340M	6-23-W76C-031	(OPTION)
37	SCREW M2*4L KI BK/Z ICT NY	6-35-B6120-BR0	
38	SCREW M2*4L KI BZ ICT NY (S-AL) 3.0	6-35-B6120-3RD	
39	SCREW M2*4L KI BK/Z ICT NY (S-AL) 3.0	6-35-B6120-2RE	
40	BOTTOM CASE MODULE W760S	6-39-W76S3-013	
41	SCREW M2*4L KI BK/Z NY ICT	6-35-B612S-BR0	
42	RUBBER (REAR) RUBBER 60*64*4 SILICONE W760S	6-47-M76SB-010	
43	CPU THERMAL MODULE W760CU	6-31-W76CN-100	
44	FAN MODULE W740S	6-31-M74SS-102	
45	CPU COVER MODULE W760CU	6-42-W76CS-100	
46	RUBBER (FRONT) RUBBER 60*64*4 SILICONE W760S	6-47-M67U1-D40	
47	ODD BRIDGE BOARD V10 W760S	6-77-W760N-D01	
48	TAPE MYLAR (C) MYLAR M550J	6-40-M55J2-030	
49	MB MYLAR PET (I) (S-AL) W760TLN	6-40-W76TS-010	
50	MBP S LI 108V/720M 3SP SMP/PANASONIC W760S	6-87-M74JS-4CA	(OPTION)
50	MBP S LI 108V/444M 3SP SMP/PANASONIC W760S	6-87-M74JS-4CA	(OPTION)
50	MBP S LI 108V/444M 3SP SMP/PANASONIC W760S	6-87-M660S-4PA	(OPTION)
50	MBP S LI 108V/444M 3SP SMP/PANASONIC W760S	6-87-M74JS-4MA	(OPTION)
50	MBP S LI 108V/444M 3SP SMP/PANASONIC W760S	6-87-M74JS-4U4A	(OPTION)
51	TOP CASE SUPPORT RUBBER 60*64*4 SILICONE W760S	6-47-W76CS-010	
52	MYLAR 40*30*11T FRB3 + 3M-607 M735T	6-40-M7351-020	

Figure A - 5
Bottom

A.Part Lists

LCD

Figure A - 6
LCD

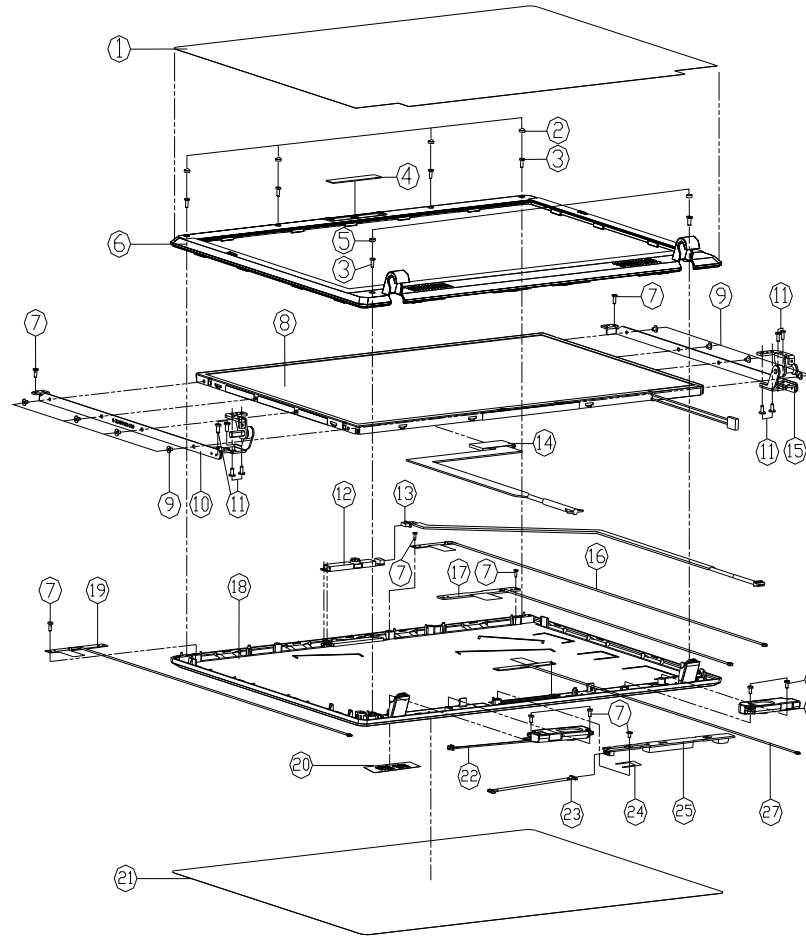

ITEM	PART NAME	PART NO	REMARK
1	LCD PROTECT FILM (TYPE 1) (W/AD) (W/AD) (W/AD)	6-40-W76S1-041	
2	LCD FRONT COVER MODULE (W/AD) (W/AD) (W/AD)	6-47-W76S1-050	
3	SCREW M2.5x5L KI BK/2 ICT NY	6-35-B6120-5R0	
4	CCD LINES (P/NAL) (W/AD) (W/AD) (W/AD)	6-42-W76S1-011	W/ CCD
4	CCD LINES (P/NAL) (W/AD) (W/AD) (W/AD)	6-42-W76S1-011-1	FOR W76SCUF V2 (L) (L)
4	CCD LINES (P/NAL) (W/AD) (W/AD) (W/AD)	6-42-W76S1-020	W/AD CCD
5	LCD FRONT COVER MODULE (W/AD) (W/AD) (W/AD)	6-47-W76S1-030	
6	LCD FRONT COVER MODULE (W/AD) (W/AD) (W/AD)	6-39-W76S1-012	FOR W76KCU
6	LCD FRONT COVER MODULE (W/AD) (W/AD) (W/AD)	6-39-W76S1-012-1	FOR W76SCUF (W/AD) (W/AD)
7	ANTENNA BRACKET (FOR 2.4GHz) (FOR 2.4GHz) (FOR 2.4GHz)	6-23-7W76C-011	
8	LCD TSP-HD AU (RESIN) (V2) (GLASS) (TYPE 1)	6-50-LA157-002	FOR LED PANEL (FOR 3510)
8	LCD TSP-HD AU (RESIN) (V2) (GLASS) (TYPE 1)	6-50-L8155-V03	FOR LED PANEL (FOR 3510)
8	LCD TSP-FHD AU (RESIN) (V2) (GLASS) (TYPE 1)	6-50-L8257-G01	FOR LED PANEL (FOR W76KCU/W76SCUF)
8	LCD TSP-FHD AU (RESIN) (V2) (GLASS) (TYPE 1)	6-50-L8257-G00	FOR LED PANEL (FOR W76KCU)
8	LCD TSP-HD AU (RESIN) (V2) (GLASS) (TYPE 1)	6-50-LA157-G00	FOR LED PANEL (FOR W76KCU)
8	LCD TSP-HD AU (RESIN) (V2) (GLASS) (TYPE 1)	6-50-L8155-G00	FOR LED PANEL (FOR W76KCU)
8	LCD TSP-HD AU (RESIN) (V2) (GLASS) (TYPE 1)	6-50-L8162-D00	FOR LED PANEL (FOR W76SCUF (W/AD) (W/AD))
9	SCREW M2.5x5L KI BK/2 ICT NY	6-35-B1120-3RE	
10	LCD HINGE-L (SECC) (W76S) (TYPE 1) (TYPE 1)	6-33-W7601-030-1	FOR LED PANEL (FOR W76SCUF (W/AD) (W/AD))
10	LCD HINGE-L (SECC) (W76S) (TYPE 1) (TYPE 1)	6-33-W7601-031-1	FOR W76S1CU
11	SCREW M2.5x5L KI BK/2 ICT NY	6-35-B6125-5RA	
12	AVC CAMERA BRACKET (FOR W76S) (FOR W76S) (FOR W76S)	6-88-W76SC-4900	
13	WIRE CABLE (FOR W76S) (FOR W76S) (FOR W76S)	6-43-W76S1-022	
14	WIRE CABLE (FOR W76S) (FOR W76S) (FOR W76S)	6-43-W76S1-010-1	FOR 6-35-B1120-3RE
14	WIRE CABLE (FOR W76S) (FOR W76S) (FOR W76S)	6-43-W76S1-010	FOR 6-35-B1120-3RE
15	LCD HINGE-R (SECC) (W76S) (TYPE 1) (TYPE 1)	6-33-W7601-020-1	FOR LED PANEL (FOR W76SCUF (W/AD) (W/AD))
15	LCD HINGE-R (SECC) (W76S) (TYPE 1) (TYPE 1)	6-33-W7601-021-1	FOR W76S1CU
16	ANTENNA BRACKET (FOR 2.4GHz) (FOR 2.4GHz) (FOR 2.4GHz)	6-23-7W76C-021	(OPTION)
17	ANTENNA BRACKET (FOR 2.4GHz) (FOR 2.4GHz) (FOR 2.4GHz)	6-23-7W76C-010	(OPTION)
18	LCD BACK COVER MODULE (W/AD) (W/AD) (W/AD)	6-39-W76S1-022	FOR W76KCU
18	LCD BACK COVER MODULE (W/AD) (W/AD) (W/AD)	6-39-W76S1-020	FOR W76S1CU/W76SCUF
18	LCD BACK COVER MODULE (W/AD) (W/AD) (W/AD)	6-39-W76S1-022	FOR W76S1CU
19	ANTENNA BRACKET (FOR 2.4GHz) (FOR 2.4GHz) (FOR 2.4GHz)	6-23-7W76C-011	FOR W76KCU (OPTION)
20	WIRE CABLE (FOR W76S) (FOR W76S) (FOR W76S)	6-45-W741S-020	FOR W76KCU
20	WIRE CABLE (FOR W76S) (FOR W76S) (FOR W76S)	6-45-W761T-020-1	FOR W76SCUF
21	WIRE CABLE (FOR W76S) (FOR W76S) (FOR W76S)	6-40-W76S1-052	FOR W76KCU
22	WIRE CABLE (FOR W76S) (FOR W76S) (FOR W76S)	6-23-5W76S-011	
23	WIRE CABLE (FOR W76S) (FOR W76S) (FOR W76S)	6-43-W74SR-011	ONLY FOR CCFI PANEL
24	INVERTER (W/AD) (W/AD) (W/AD)	6-40-W76S1-011	ONLY FOR CCFI PANEL
25	INVERTER (W/AD) (W/AD) (W/AD)	6-76-M66R-010	ONLY FOR CCFI PANEL
25	INVERTER (W/AD) (W/AD) (W/AD)	6-76-M66R-011	ONLY FOR CCFI PANEL
26	WIRE CABLE (FOR W76S) (FOR W76S) (FOR W76S)	6-23-5M74S-030	
27	ANTENNA BRACKET (FOR 2.4GHz) (FOR 2.4GHz) (FOR 2.4GHz)	6-23-7W76C-021	

COMBO

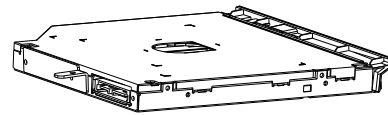
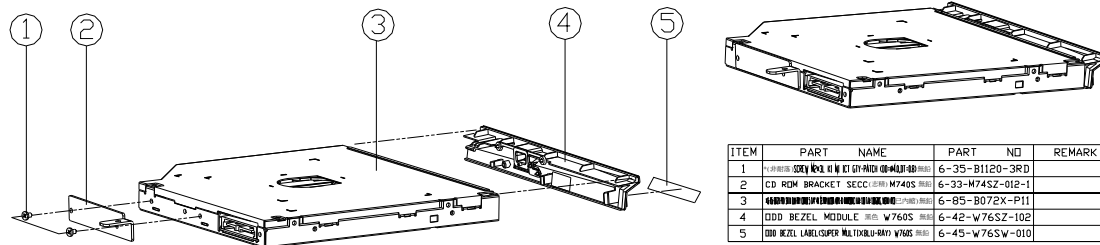

ITEM	PART NAME	PART NO	REMARK
1	FRONT BEZEL W/ CD DRIVE	6-35-B1120-3RD	
2	CD ROM BRACKET SECC	6-33-M745Z-012-1	
3	FRONT BEZEL MODULE	6-85-B072X-P11	
4	ODD BEZEL MODULE	6-42-W765Z-102	
5	ODD BEZEL LABEL/SUPER MULTIRAY	6-45-W765W-010	

Figure A - 7
COMBO

DVD-Dual Drive

Figure A - 8
DVD-Dual Drive

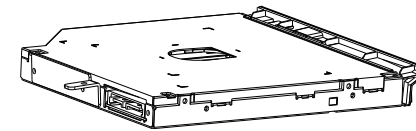
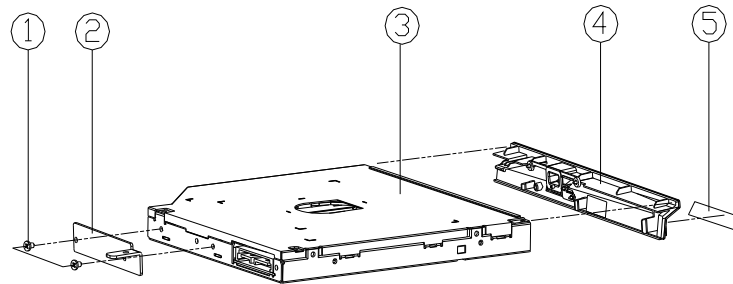

ITEM	PART NAME	PART NO	REMARK
1	ODD BEZEL MODULE KIT (MULTI-BAY)	6-35-B1120-3RD	
2	CD ROM BRACKET SECC (6.35) M740S	6-33-M74SZ-012-1	
3	ODD BEZEL LABEL (MULTI-BAY)	6-85-B072X-P11	
4	ODD BEZEL MODULE (W760S)	6-42-W76SZ-102	
5	ODD BEZEL LABEL (SUPER MULTIBAY)	6-45-W76SW-010	

Appendix B: Schematic Diagrams

This appendix has circuit diagrams of the *W760CU[H]/W765CU[H]* notebook's PCB's. The following table indicates where to find the appropriate schematic diagram.

Diagram - Page	Diagram - Page	Diagram - Page
<i>System Block Diagram - Page B - 2</i>	<i>IBEXPEAK - M 2/9 - Page B - 22</i>	<i>Power 1.IVS_VTT - Page B - 42</i>
<i>Clock Generator - Page B - 3</i>	<i>IBEXPEAK - M 3/9 - Page B - 23</i>	<i>Power VGFX_CORE - Page B - 43</i>
<i>Processor 1/7 - Page B - 4</i>	<i>IBEXPEAK - M 4/9 - Page B - 24</i>	<i>V-Core - Page B - 44</i>
<i>Processor 2/7 - Page B - 5</i>	<i>IBEXPEAK - M 5/9 - Page B - 25</i>	<i>M92 VDDC - Page B - 45</i>
<i>Processor 3/7 - Page B - 6</i>	<i>IBEXPEAK - M 6/9 - Page B - 26</i>	<i>AC-IN, Charger - Page B - 46</i>
<i>Processor 4/7 - Page B - 7</i>	<i>IBEXPEAK - M 7/9 - Page B - 27</i>	<i>HDMI - Page B - 47</i>
<i>Processor 5/7 - Page B - 8</i>	<i>IBEXPEAK - M 8/9 - Page B - 28</i>	<i>Audio Board - Page B - 48</i>
<i>Processor 6/7 - Page B - 9</i>	<i>IBEXPEAK - M 9/9 - Page B - 29</i>	<i>Finger Sensor Board TCS4X - Page B - 49</i>
<i>Processor 7/7 - Page B - 10</i>	<i>New Card, Mini PCIE - Page B - 30</i>	<i>Power Switch Board for M74 - Page B - 50</i>
<i>DDRIII SO-DIMM_0 - Page B - 11</i>	<i>3G, TPM - Page B - 31</i>	<i>Finger Board for M74 - Page B - 51</i>
<i>DDRIII SO-DIMM_1 - Page B - 12</i>	<i>USB, Fan, TP, FP, Multi Con - Page B - 32</i>	<i>Power Switch Board for M76 - Page B - 52</i>
<i>Panel, Inverter, CRT - Page B - 13</i>	<i>Card Reader (JMC251) - Page B - 33</i>	<i>External ODD Board for W76 - Page B - 53</i>
<i>M92 S2 PCIE Interface - Page B - 14</i>	<i>SATA ODD, LED, Hotkey, LID, SW - Page B - 34</i>	<i>ODD Board for M760T - Page B - 54</i>
<i>M92 S2 Main Generic - Page B - 15</i>	<i>LAN, Modem - Page B - 35</i>	<i>Click Finger Board for M77 - Page B - 55</i>
<i>M92 S2 DP Power - Page B - 16</i>	<i>Audio Codec ALC272 - Page B - 36</i>	<i>Multi Function Board - Page B - 56</i>
<i>M92 S2 Power - Page B - 17</i>	<i>KBC-ITE IT8502E - Page B - 37</i>	
<i>M92 S2 MEM Interface - Page B - 18</i>	<i>5VS, 3VS, 3.3VM, 1.05VS, VIN1 - Page B - 38</i>	
<i>M92 S2 DDR2 Memory - Page B - 19</i>	<i>Power 3.3V/5V - Page B - 39</i>	
<i>M92 S2 LVDS & Straps - Page B - 20</i>	<i>Power 1.8V - Page B - 40</i>	
<i>IBEXPEAK - M 1/9 - Page B - 21</i>	<i>Power 1.5V/0.75V - Page B - 41</i>	

Table B - 1
**Schematic
Diagrams**



Version Note

The schematic diagrams in this chapter are based upon version 6-7P-M77CA-008. If your mainboard (or other boards) are a later version, please check with the Service Center for updated diagrams (if required).

System Block Diagram

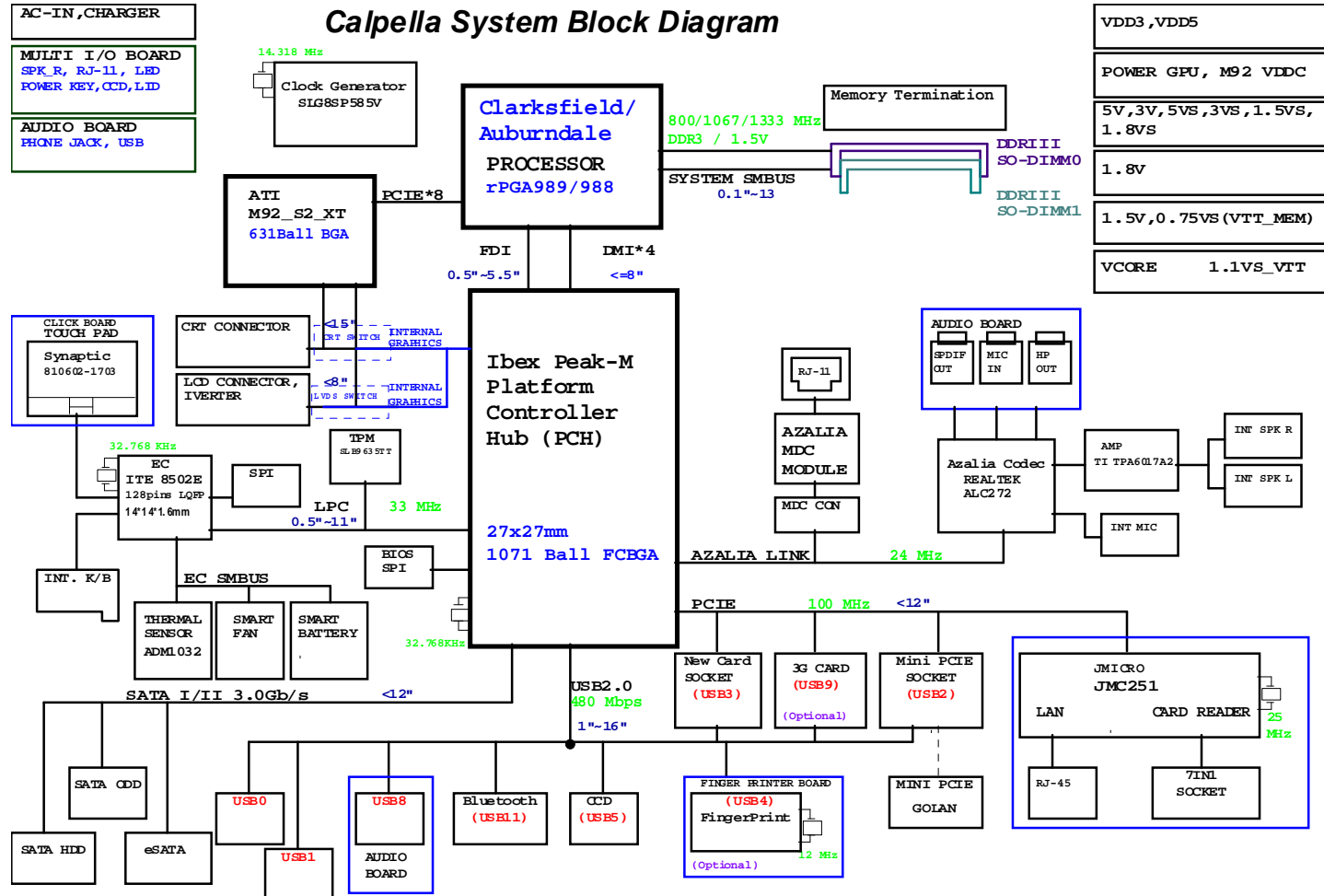

Sheet 1 of 55
System Block
Diagram

B.Schematic Diagrams

Clock Generator

CLOCK GENERATOR

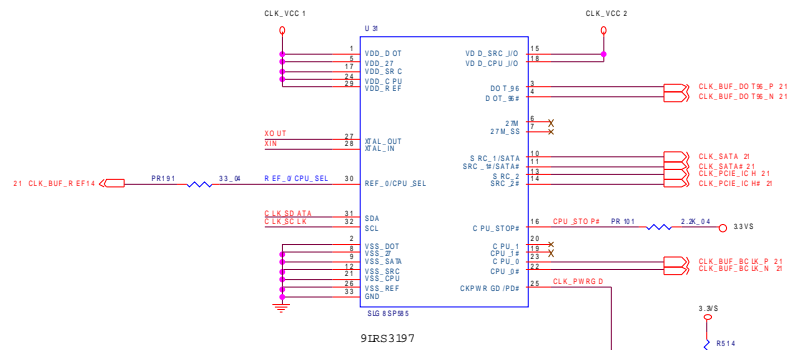

CLKGEN POWER

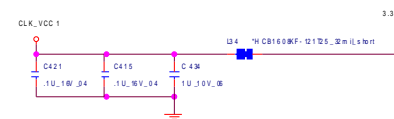

0.1uF near the every power pin

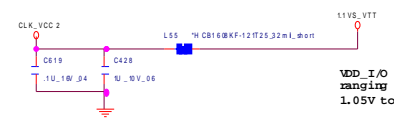

0.1uF near the every power pin

VDD_I/O can be ranging from 1.05V to 3.3V

SMBus

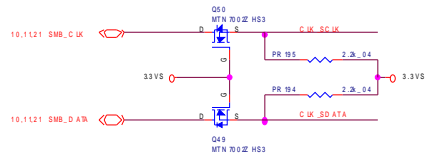

CPU_SEL_During CK_PEWGD Latch Pin1

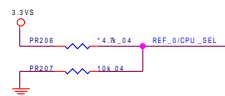

PIN_30	CPU_0	CPU_1
0 (default)	133MHz	133MHz
1 (0.7V-1.5V)	100MHz	100MHz

EMI



EMI Capacitor

Sheet 2 of 55
Clock Generator

Processor 1/7

PROCESSOR 1/7 (DMI,PEG,FDI)

It applies to Auburndale and Clarkfield discrete graphic designs.
If discrete graphic chip is used for Auburndale, Vaux (GPU core) rail can be connected to GND if motherboard only supports discrete graphics and also in a common motherboard design if GPU VR is not stuffed. On the other hand, if the VR is stuffed Vaux can be left floating in a common motherboard design (Gfx VR keeps Vaux from floating).
In addition, FDI_LIN[7:0] and FDI_LIN[7:0] can be left floating on the PCB.
The GSK_IMM, FDI_FSYN[0], FDI_FSYN[1], FDI_LSYN[0], FDI_LSYN[1], and FDI_LIF signals should be tied to GND through 1K 04 resistors in the common motherboard design case. Please note that if these signals are left floating, there are no functional impacts but a small amount of power (~15mW) maybe wasted. Vaux Sense and VauxSense on Auburndale can be left as no connect.
DPA_SV_SCLK and DPA_SV_SCLK# can be connected to RD on Auburndale directly if motherboard only supports discrete graphics. In a common motherboard design, these pins are driven via PCH even if graphics is disabled by BIOS but no external termination is required.

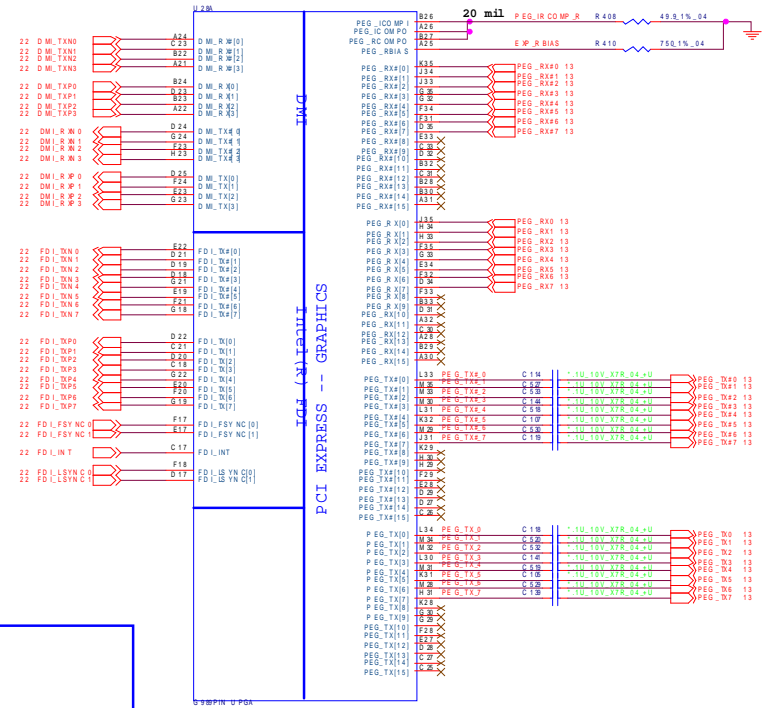
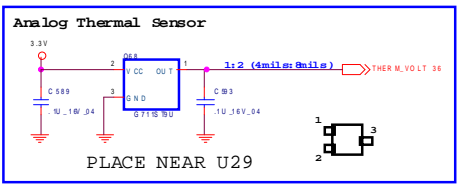
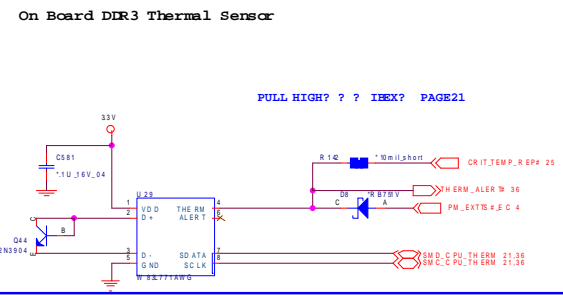

Processor 2/7

PROCESSOR 2/7 (CLK,MISC,JTAG)

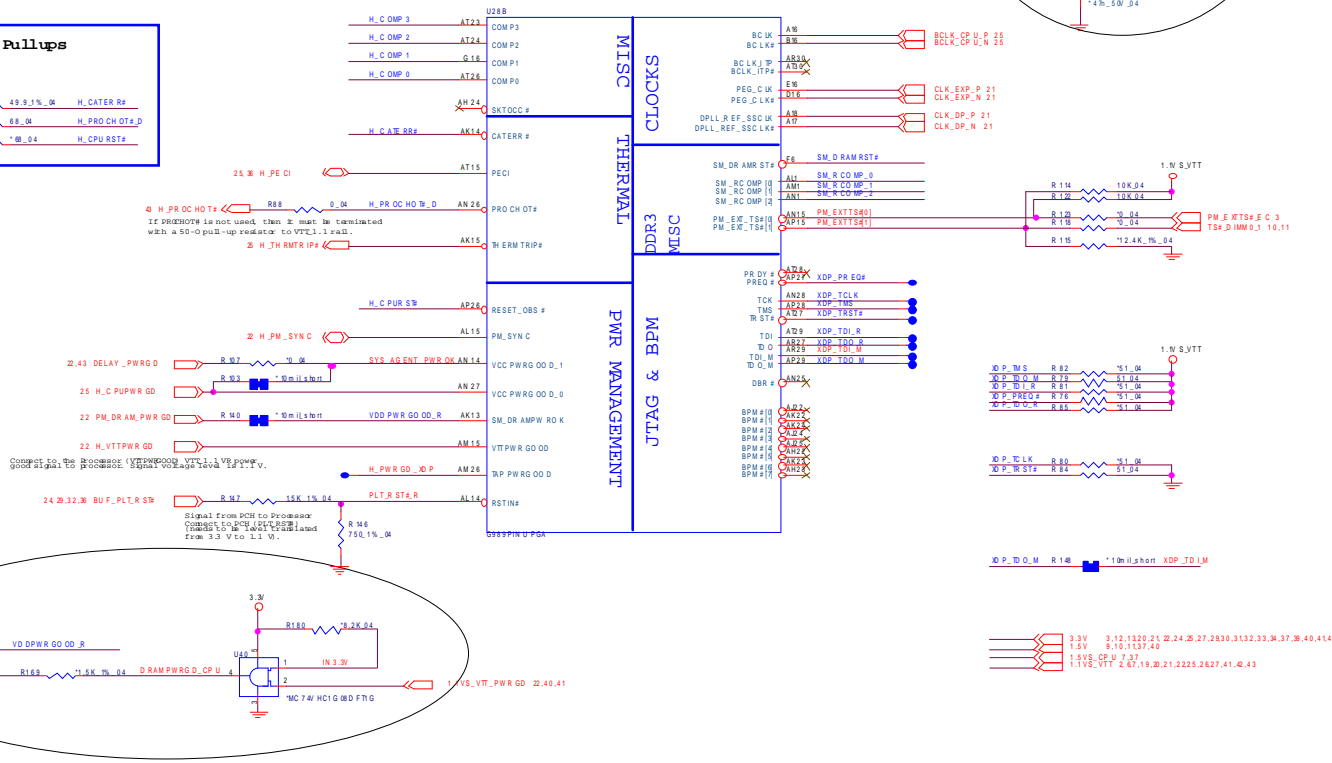
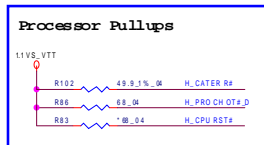
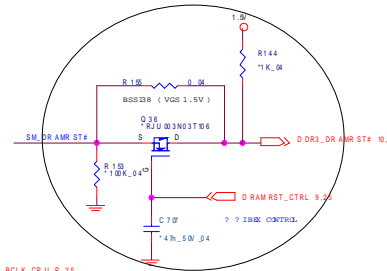
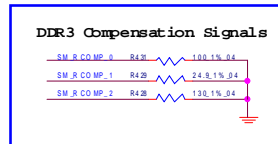
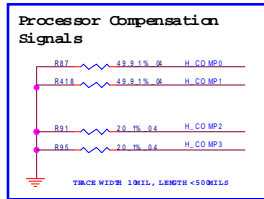

Sheet 4 of 55
Processor 2/7

B.Schematic Diagrams

Processor 4/7

PROCESSOR 4/7 (POWER)

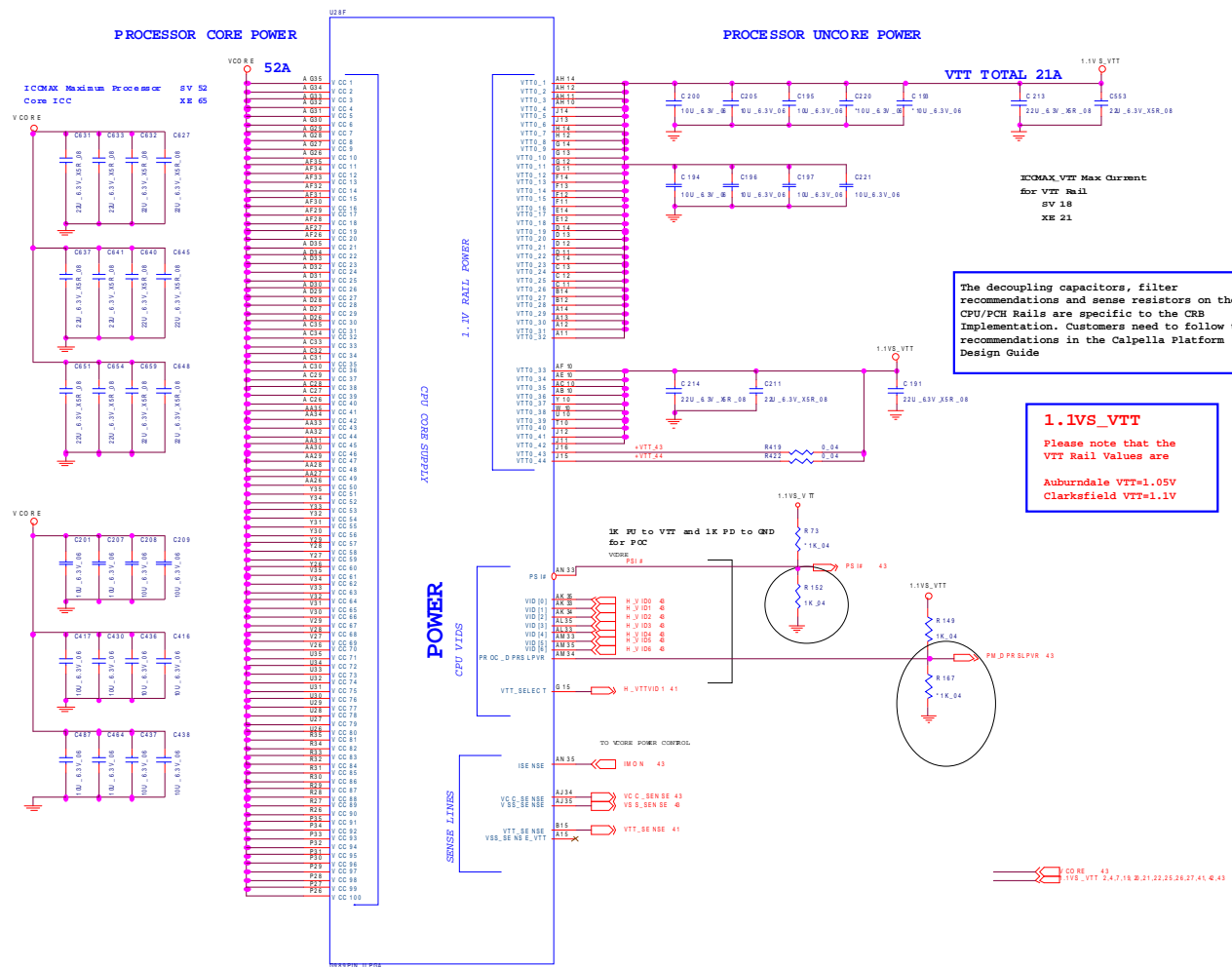

Sheet 6 of 55
Processor 4/7

B.Schematic Diagrams

Processor 5/7

PROCESSOR 5/7 (GRAPHICS POWER)

Sheet 7 of 55
Processor 5/7

Please note that the VTT Rail Values are
Auburndale VTT=1.05V
Clarksfield VTT=1.1V

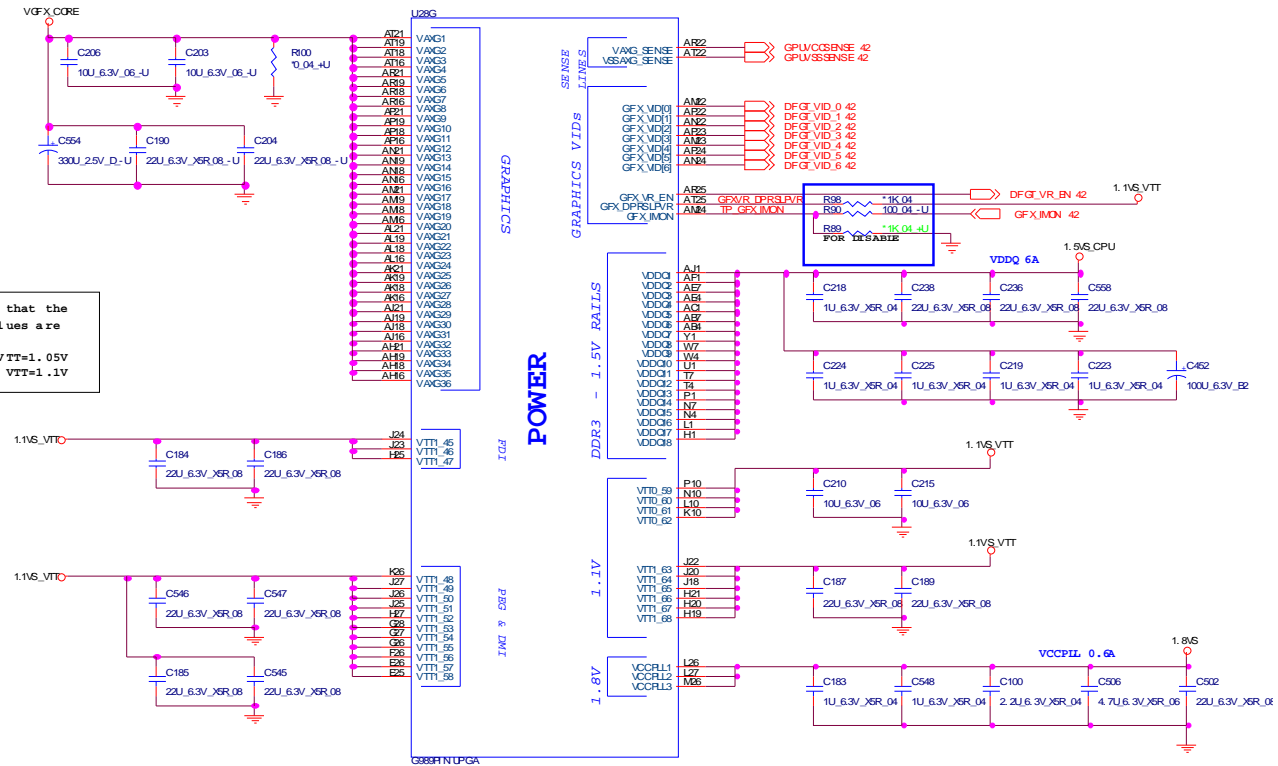

- 1.5V CPU 4,37
- 1.8V 24,26,37,39
- VFX CORE 42
- 1.1V VTT 2,4,6,19,20,21,22,25,26,27,41,42,43
- 1.5V 4,9,10,11,37,40

Processor 6/7

PROCESSOR 6/7 (GND)

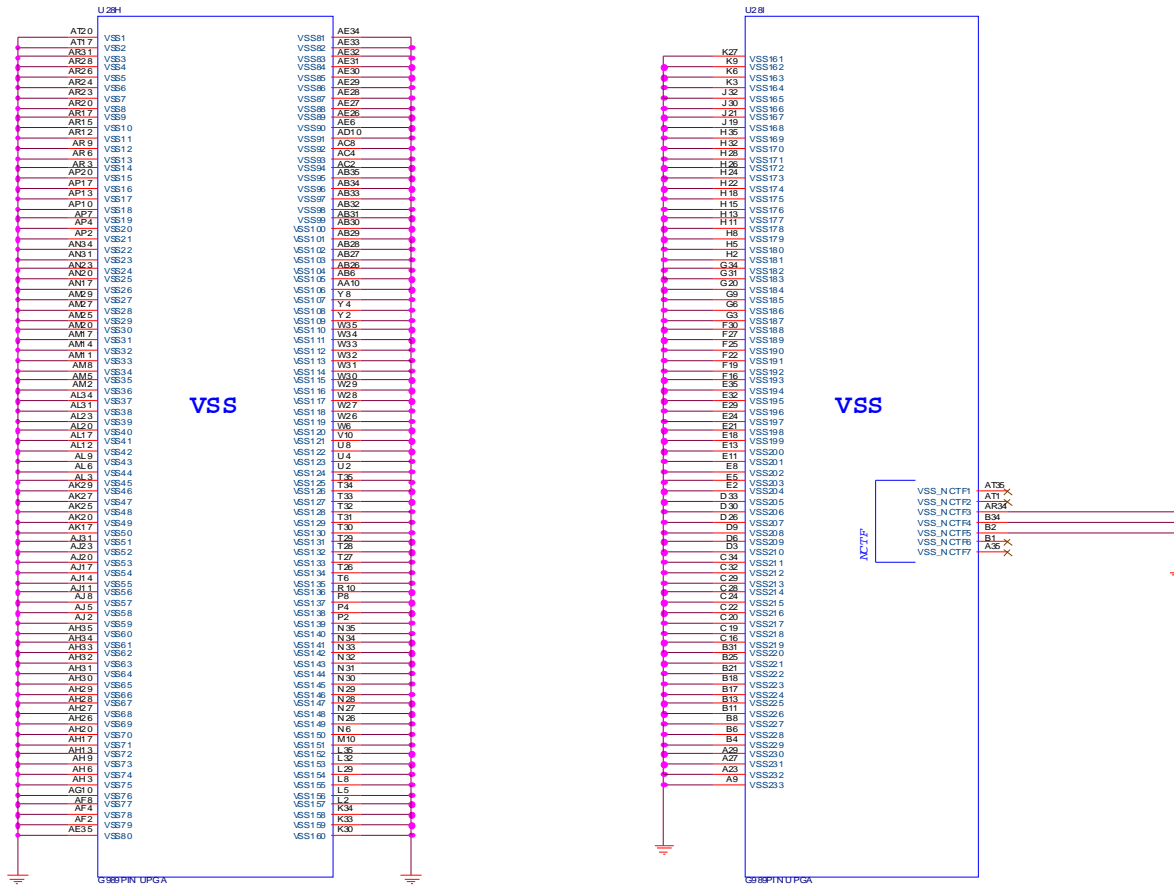

Sheet 8 of 55
Processor 6/7

Processor 7/7

PROCESSOR 7/7 (RESERVED)

Sheet 9 of 55
Processor 7/7

PCI-Express Configuration Select	
CFG0	1 : Single PEG 0 : Bifurcation enable

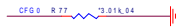

CFG3 - PCI-Express Static Lane Reversal	
CFG3	1 : Normal Operation 0 : Lane Numbers Reversed 15 -> 0, 14 -> 1, ...



CFG4 - Display Port Presence	
CFG4	1 : Disabled; No physical Display Port attached to Embedded Display Port 0 : Enabled; An external Display Port device is connected to the Embedded Display Port

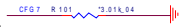
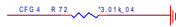

CFG7
Clarksfield (only for early samples pre-ES1) - Connect to GND with 3.01K Ohm/5% resistor

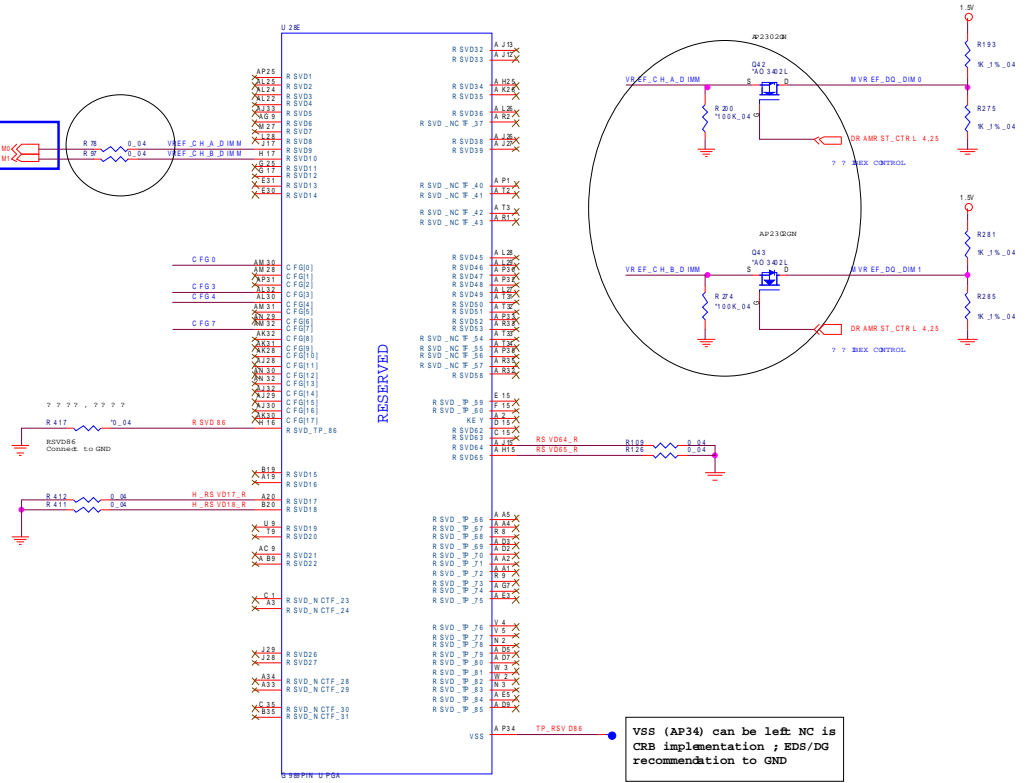

5V 4.1k H.37.40

DDRIII SO-DIMM_0

SO-DIMM A

CHANGE TO STANDARD

Layout Note:
signal/space/signal:
8 / 4 / 8

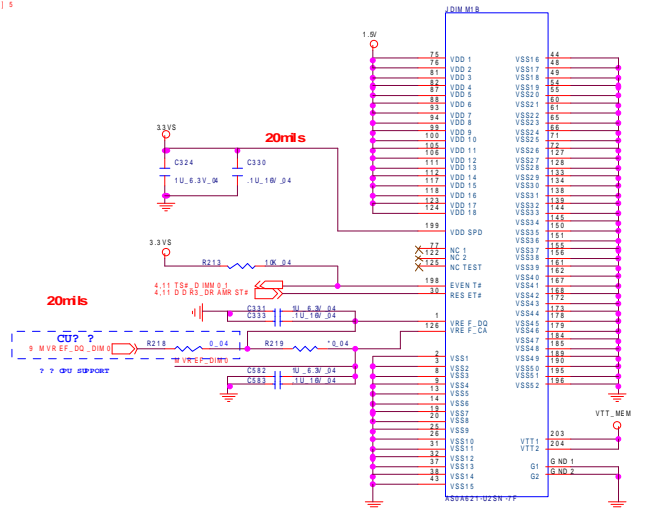
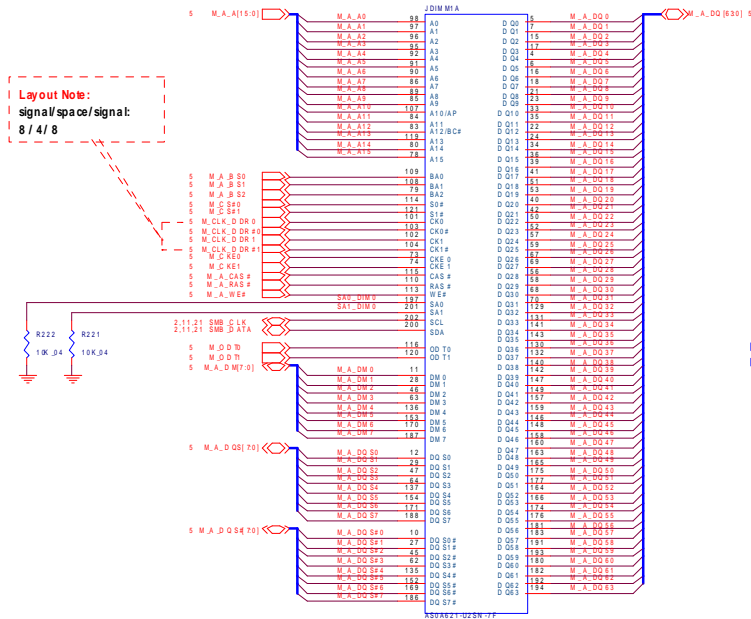

Sheet 10 of 55
DDRIII SO-DIMM_0

B.Schematic Diagrams

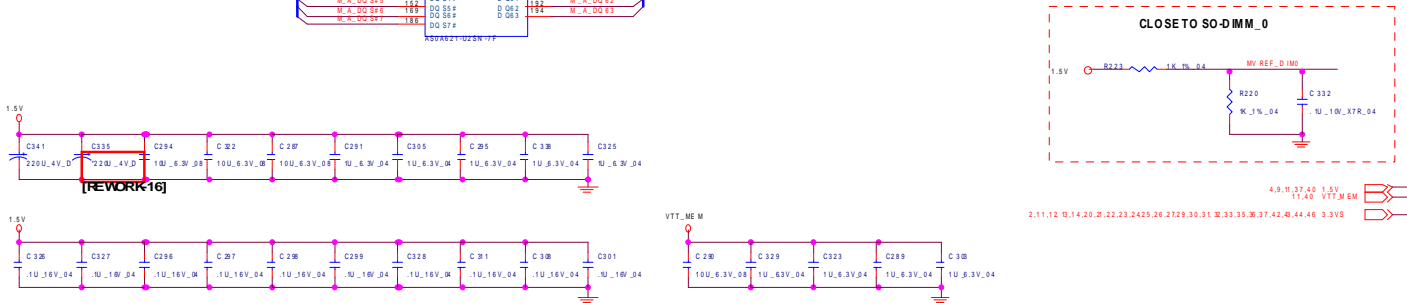

Panel, Inverter, CRT

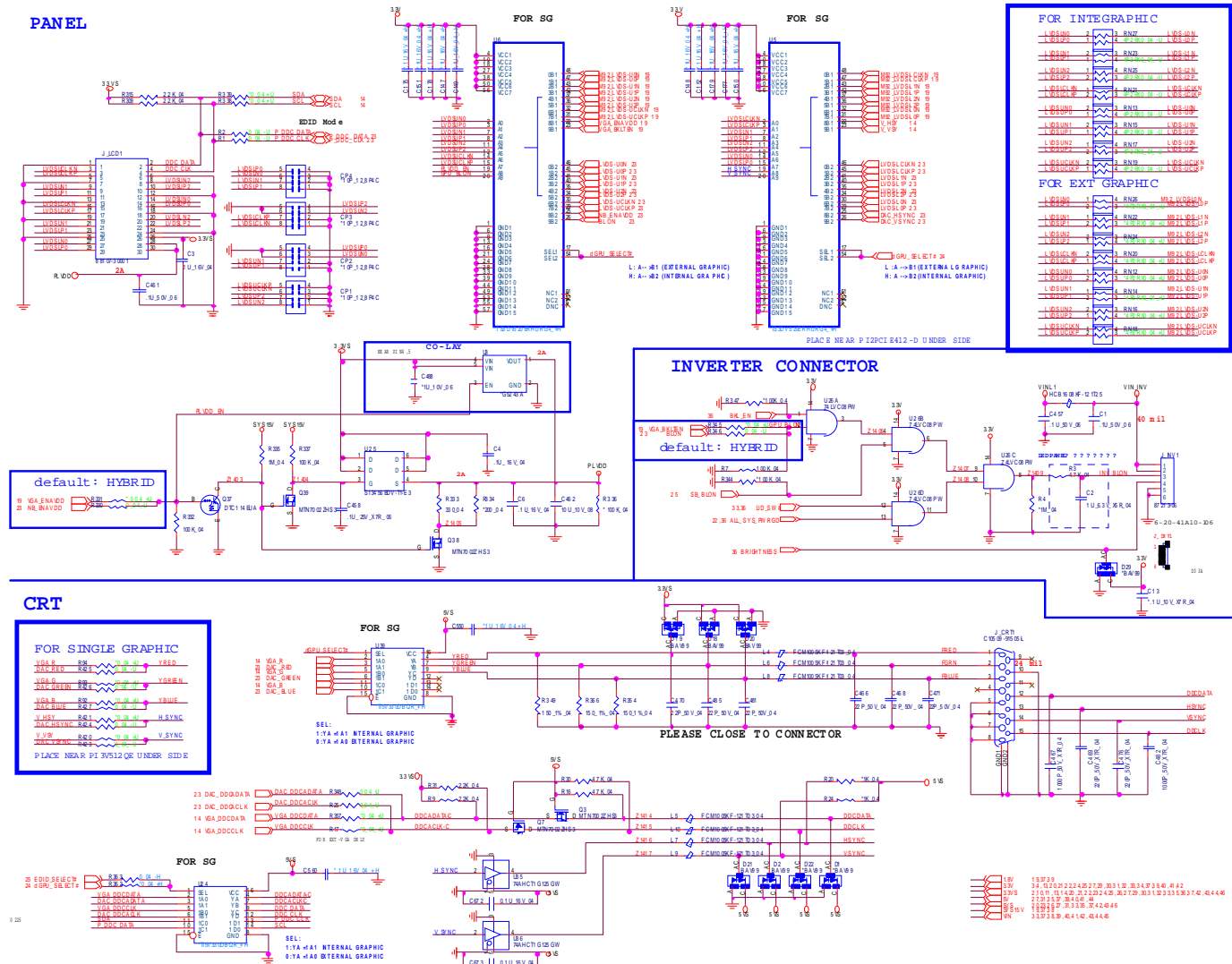

Sheet 12 of 55
Panel, Inverter,
CRT

B. Schematic Diagrams

M92 S2 PCIe Interface

Sheet 13 of 55
M92 S2 PCIe
Interface

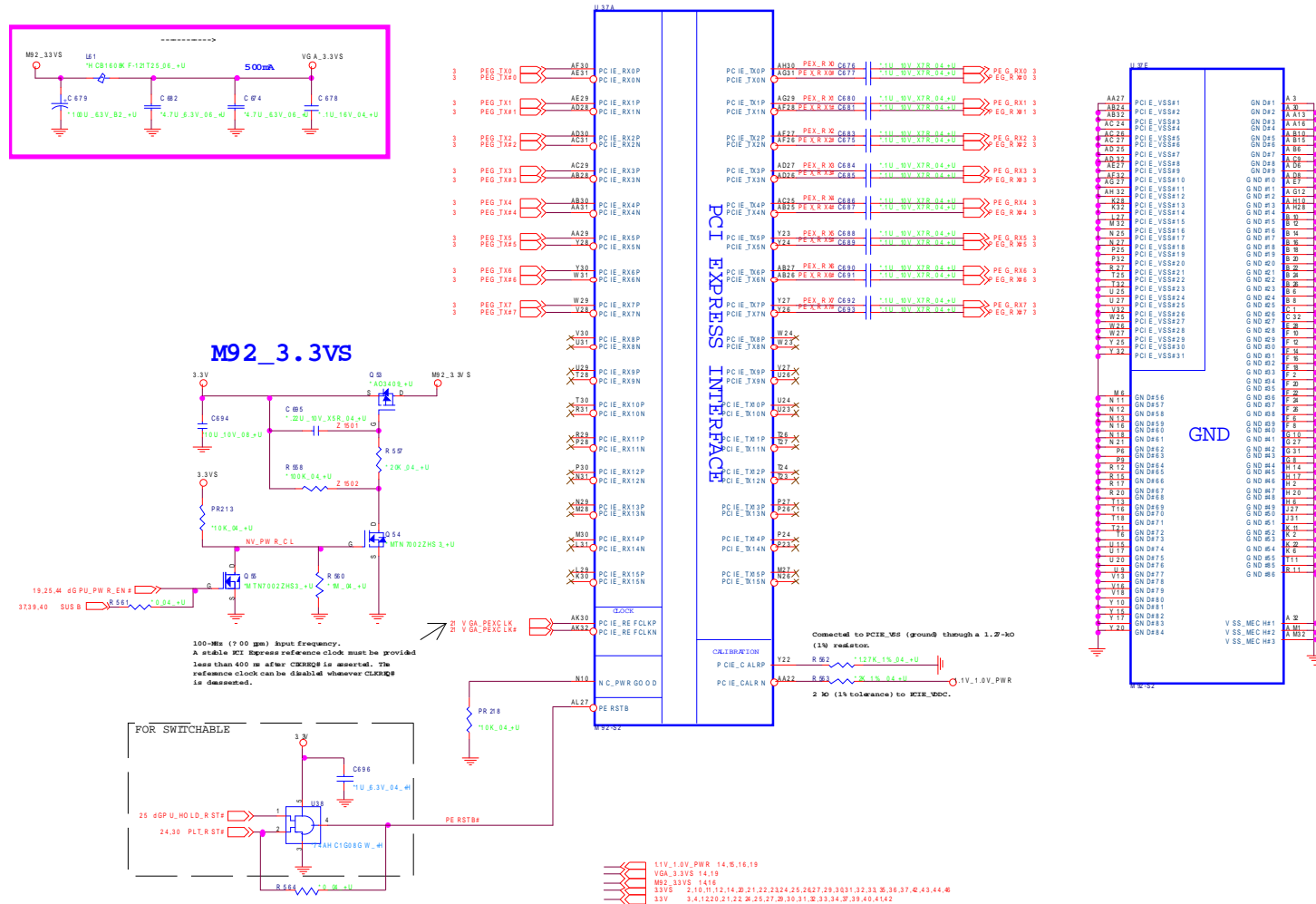

M92 S2 Main Generic

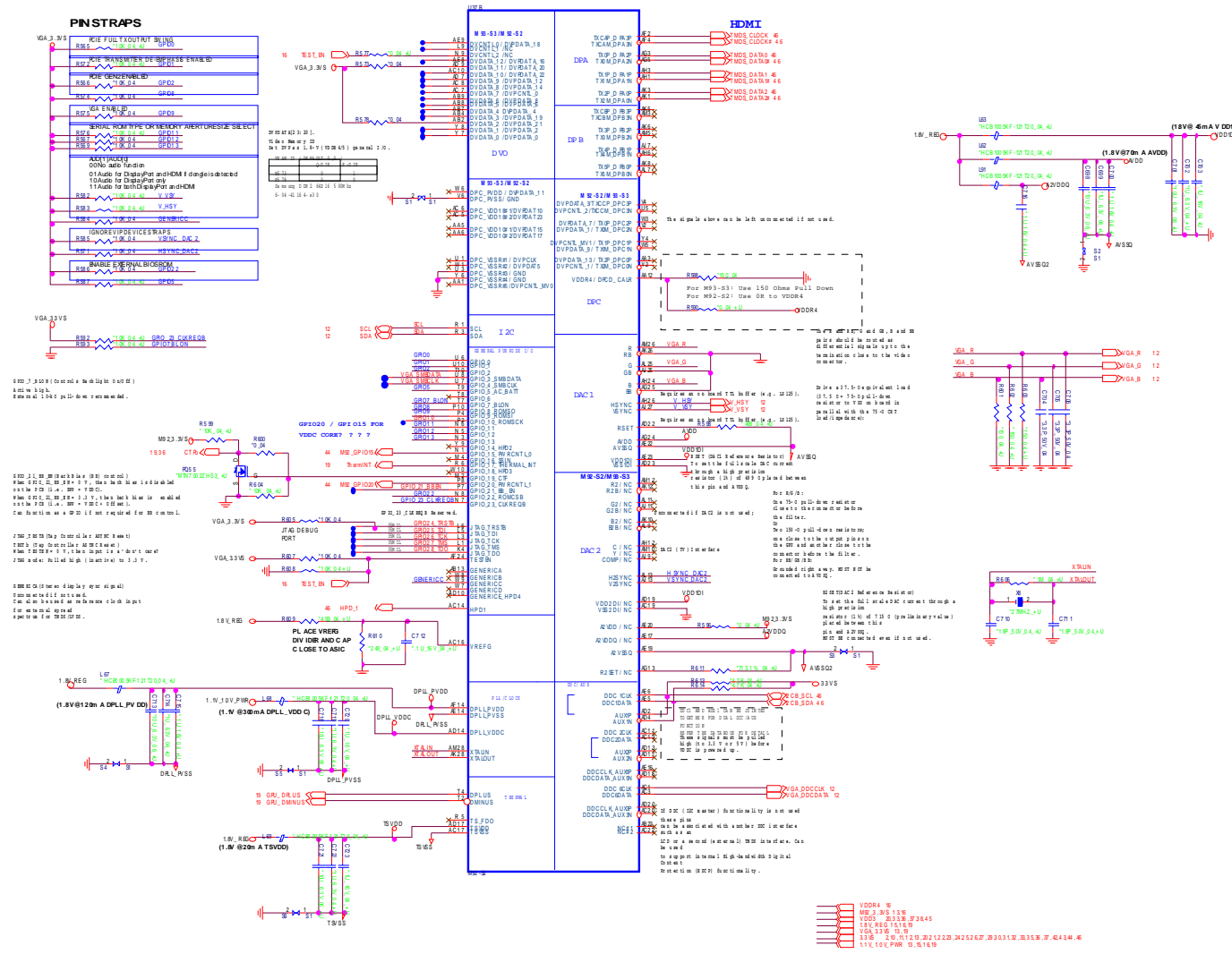

Sheet 14 of 55
M92 S2 Main
Generic

B.Schematic Diagrams

M92 S2 DP Power

Sheet 15 of 55
M92 S2 DP Power

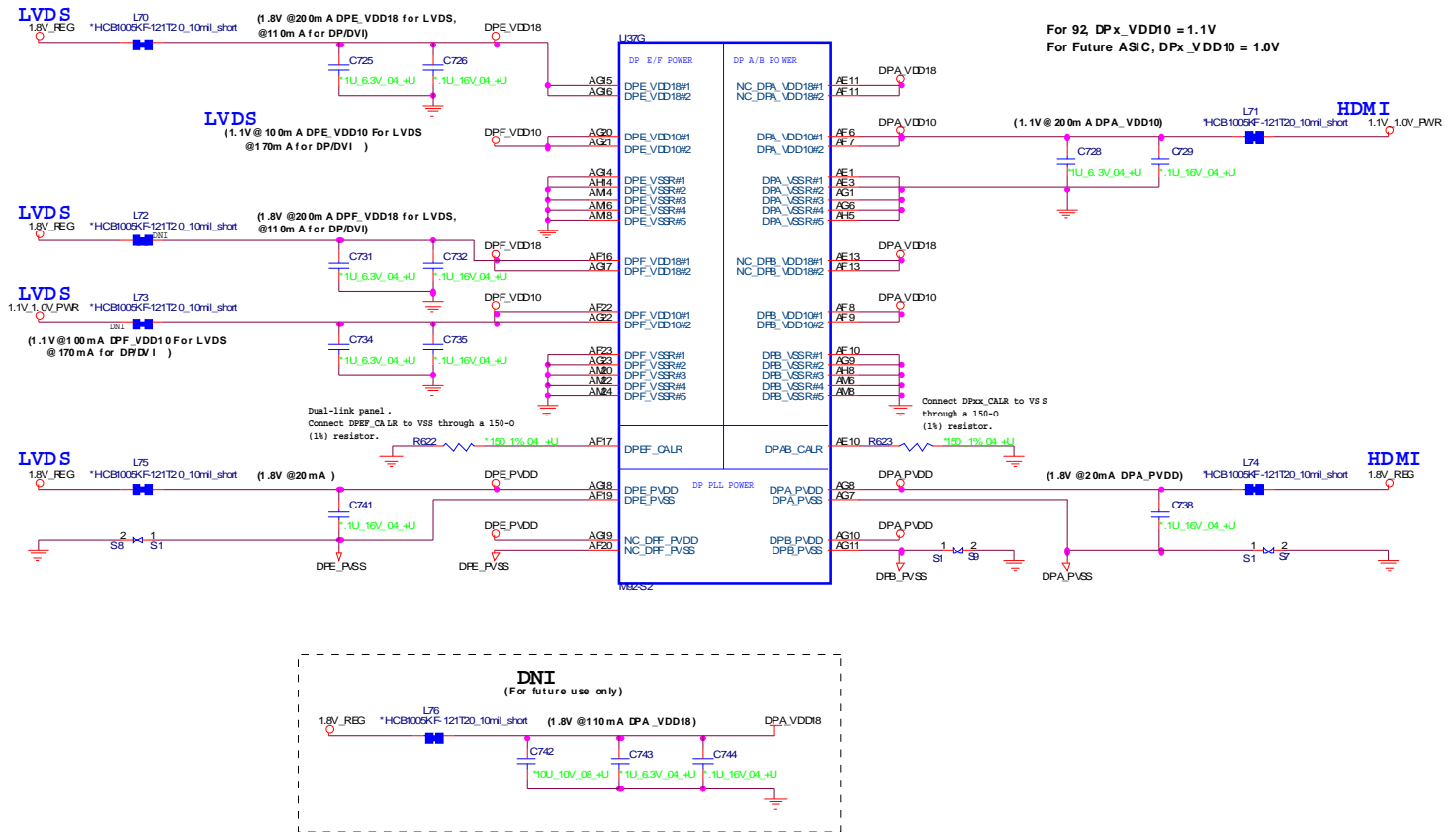

M92 S2 MEM Interface

Sheet 17 of 55
M92 S2 MEM
Interface

DDR2 Memory Interface

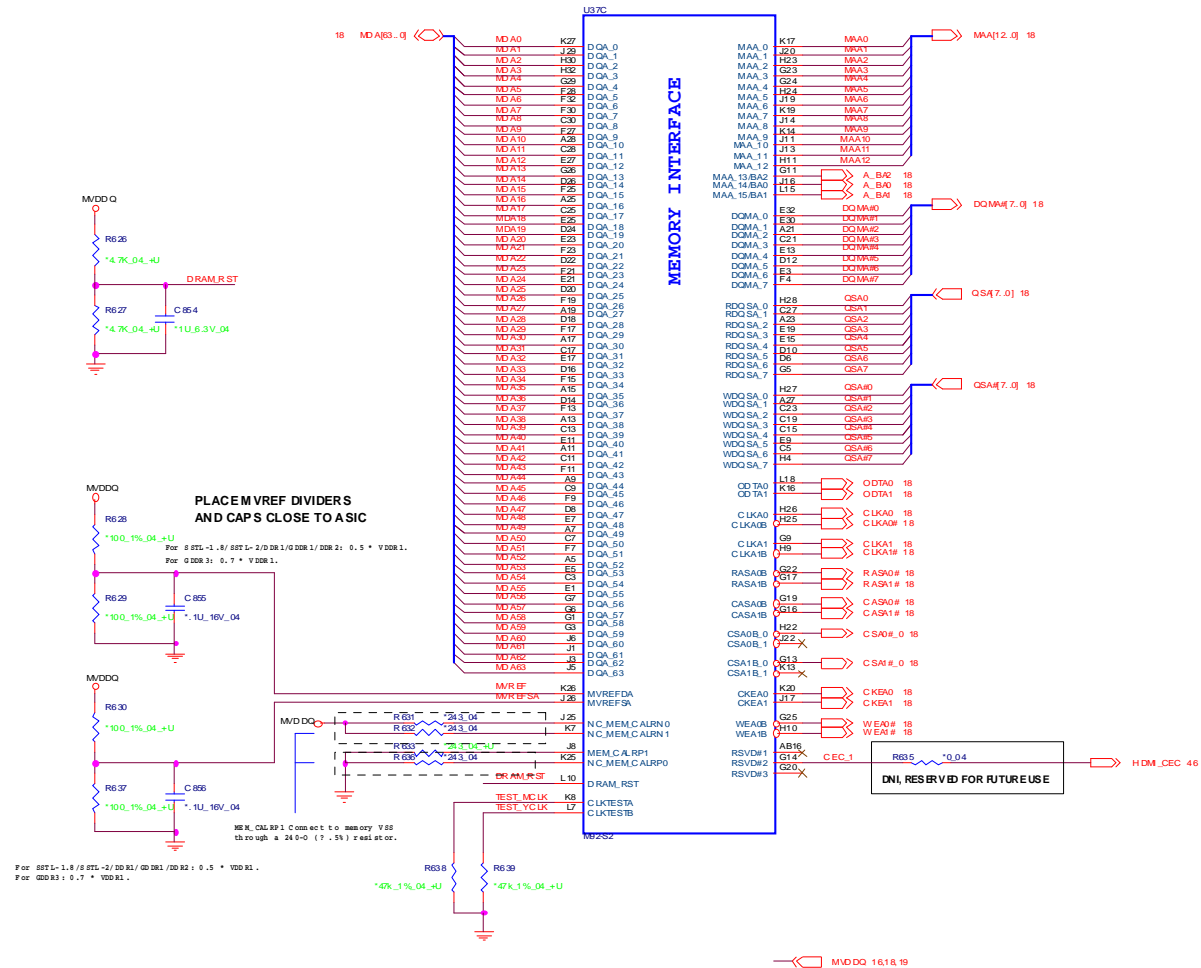

M92 S2 DDR2 Memory

512MB DDR2 MEMORY

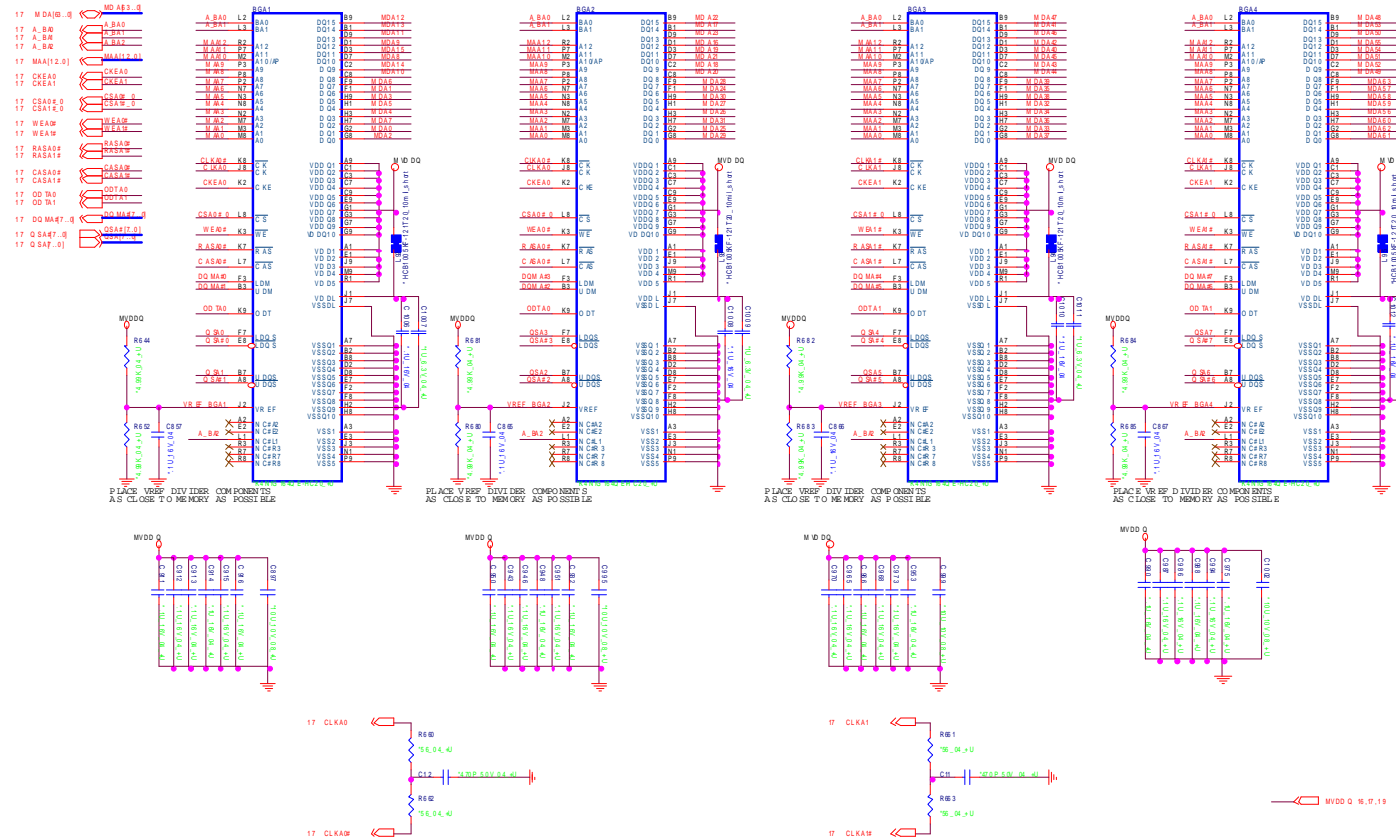

Sheet 18 of 55
M92 S2 DDR2
Memory

M92 S2 LVDS & Straps

Sheet 19 of 55
M92 S2 LVDS & Straps

LVDS Interface

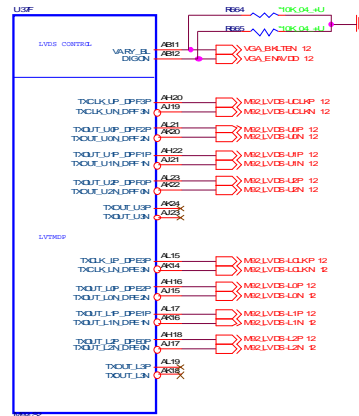

1.8V TO 1.8V_REG

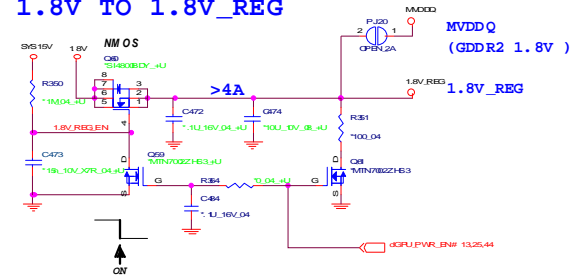

1.1V_1.0V_PWR

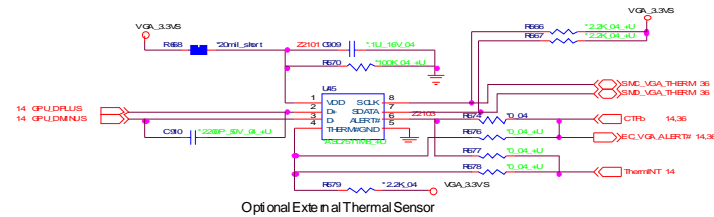
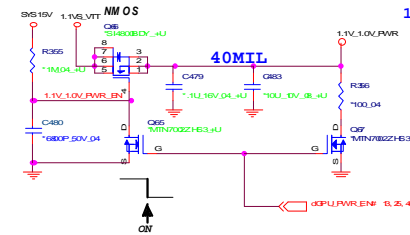

AMD RESERVED CONFIGURATION STRAPS	
ALLOW FOR PULLUP PADS FOR THESE STRAPS AND IF THESE GPIOs ARE USED, THEY MUST NOT CONFLICT DURING RESET	
H25N0	GENERIC
PULLUP PADS ARE NOT REQUIRED FOR THESE STRAPS BUT IF THESE GPIOs ARE USED, THEY MUST NOT CONFLICT DURING RESET	
CPUPLUS	

- 1.1V_1.0V_PWR 13,14,15,16
- 1.1V5_VTT 2,4,6,7,20,21,22,25,26,27,41,42,43
- 5V515V 12,25,26
- 1.8V 37,38
- 1.8V_REG 8, 9, 16
- MVDDQ 16,17,18
- VCA_3.3V5 13,14

IBEXPEAK - M 1/9

IBEXPEAK - M (HDA, JTAG, SATA)

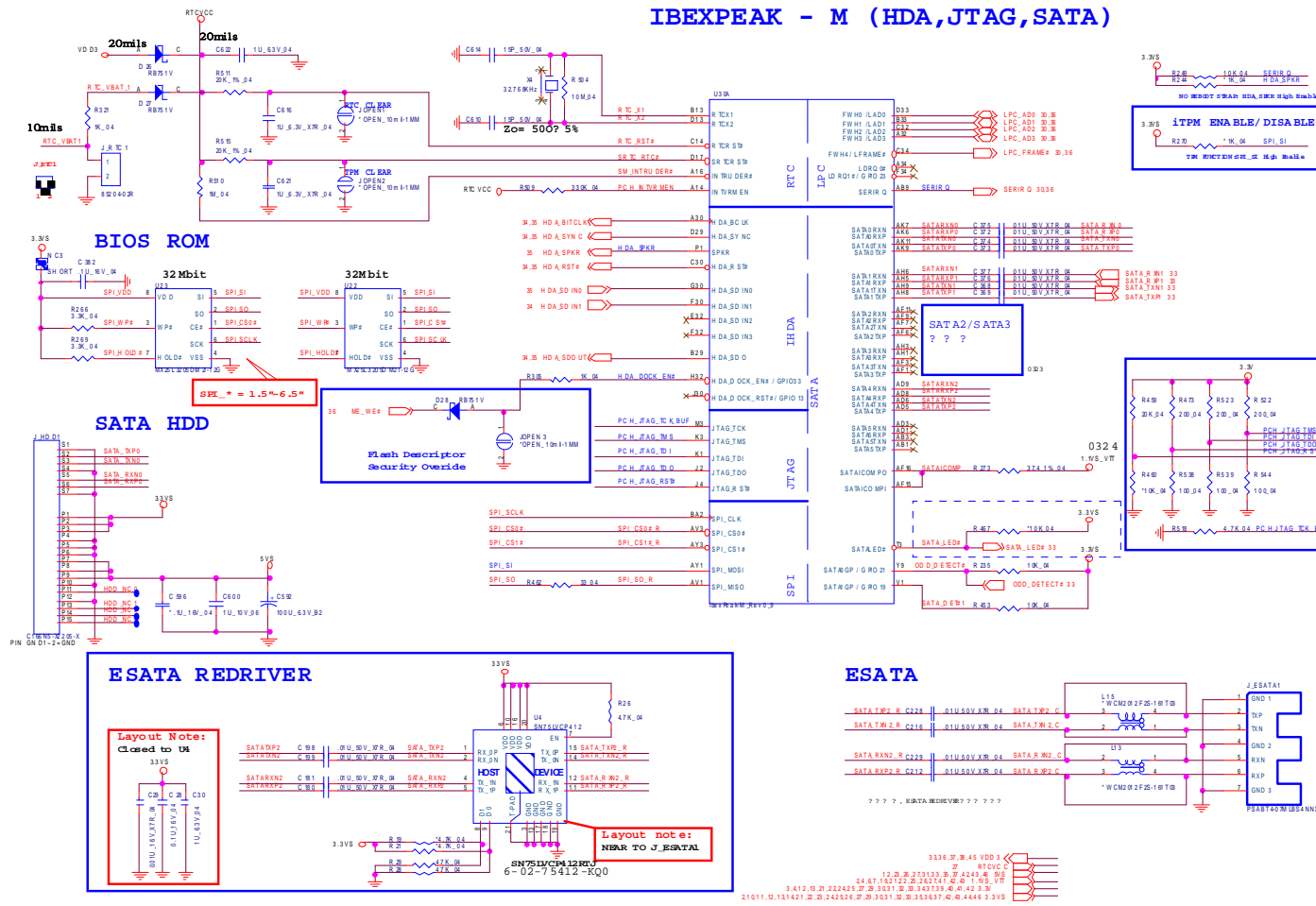

Sheet 20 of 55
IBEXPEAK - M 1/9

B.Schematic Diagrams

IBEXPEAK - M 2/9

Sheet 21 of 55
IBEXPEAK - M 2/9

PCI-E x1	Usage
Lane 1	WLAN
Lane 2	NEW CARD
Lane 3	3G
Lane 4	GLAN
Lane 5	CARD READER
Lane 6	X
Lane 7	X
Lane 8	X

IBEXPEAK - M (PCI-E, SMBUS, CLK)

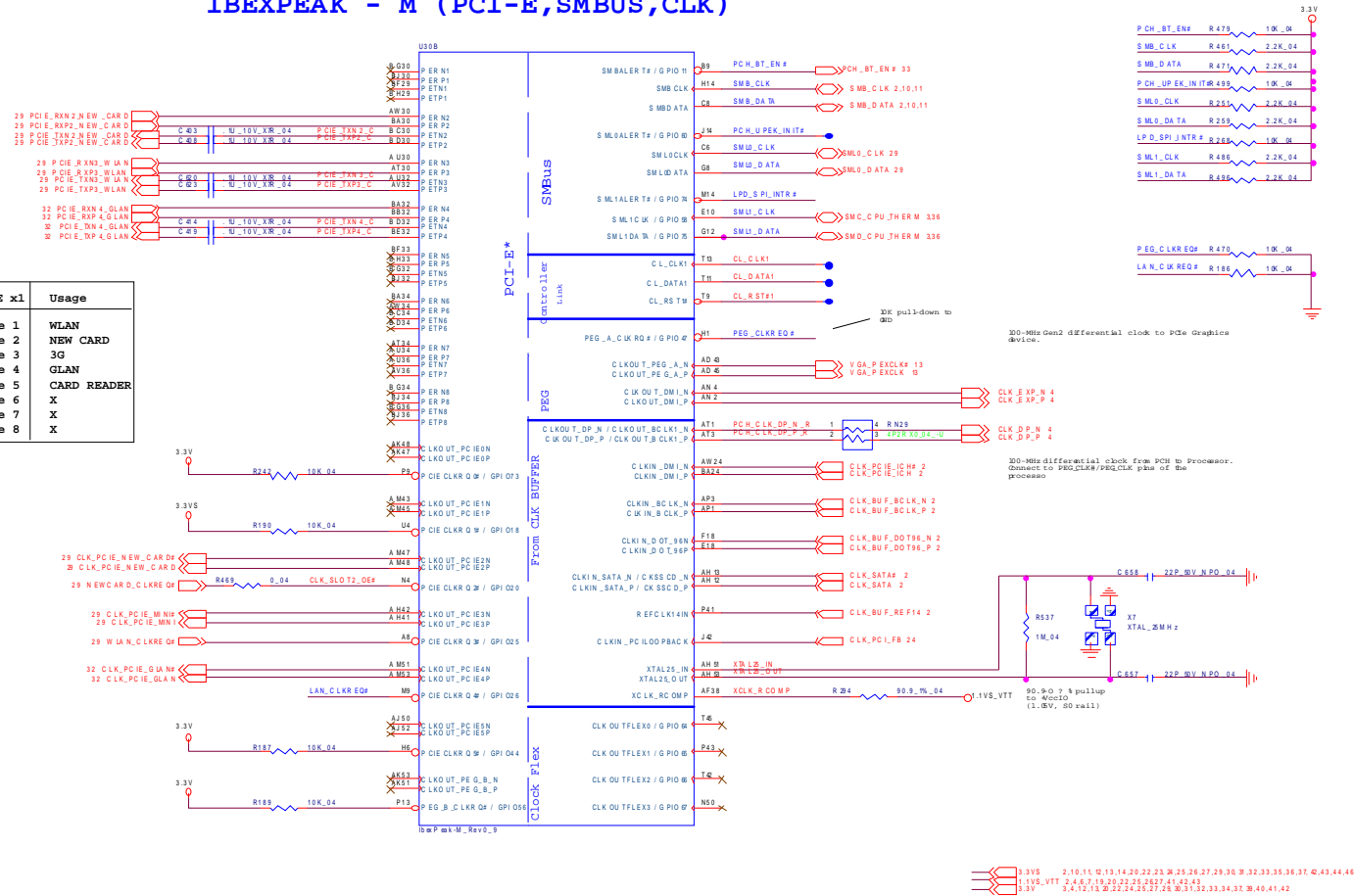

0.3V5 2.10,11,12,13,14,20,22,23,24,25,26,27,29,30,32,33,35,36,37,42,43,44,46
 1.1V5_VTT 2.44,7,15,16,22,25,26,27,41,42,43
 3.3V 3.4,12,13,22,24,25,27,28,30,31,32,33,34,37,39,40,41,42

IBEXPEAK - M 3/9

IBEXPEAK - M (DMI, FDI, GPIO)

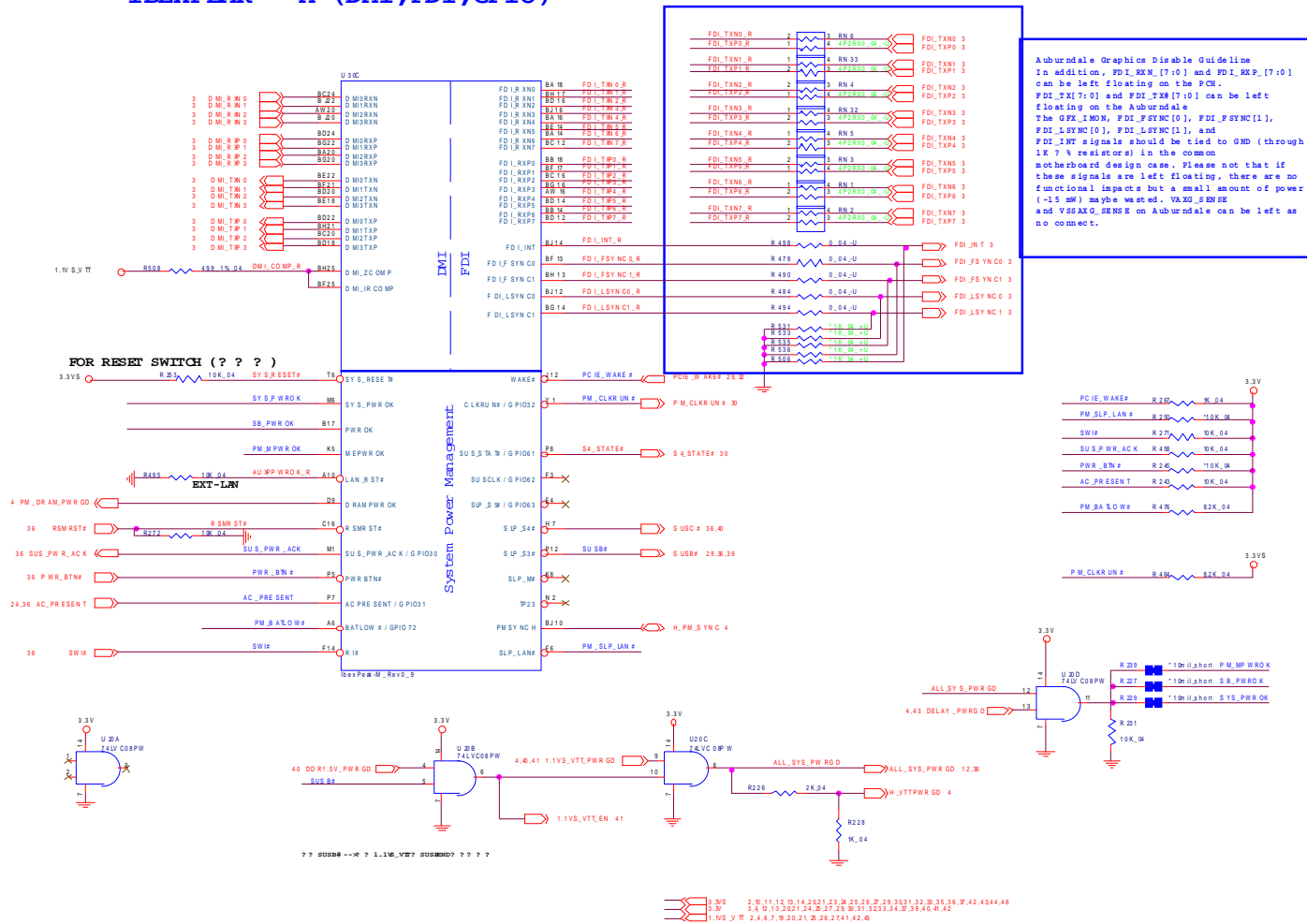

Aburdale Graphics Disable Guideline
 In addition, FDI_RXN[7:0] and FDI_RXP[7:0] can be left floating on the PCH.
 FDI_TX[7:0] and FDI_TXM[7:0] can be left floating on the Aburdale.
 The GFX_I_MON, FDI_FSYNC[0], FDI_FSYNC[1], FDI_LSYNC[0], FDI_LSYNC[1], and FDI_LNT signals should be tied to GND (through 1K Ω resistor) in the normal motherboard design case. Please not that if these signals are left floating, there are no functional impacts but a small amount of power (~1.5 mW) maybe wasted. VAD0 Sense and VSSAQ Sense on Aburdale can be left as no connect.

Sheet 22 of 55
 IBEXPEAK - M 3/9

B. Schematic Diagrams

IBEXPEAK - M 5/9

IBEXPEAK - M (PCI,USB,NVRAM)

Boot BIOS Strap		
PCI_GNT#0	PCI_GNT#1	Boot BIOS Location
0	0	LPC
0	1	Reserved (NAND)
1	0	PCI
1	1	SP1

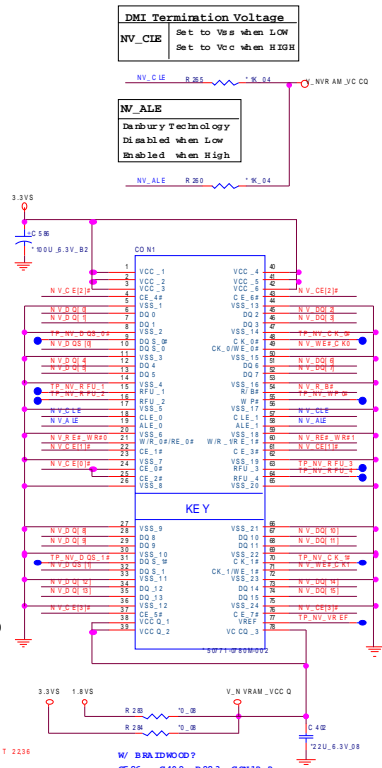
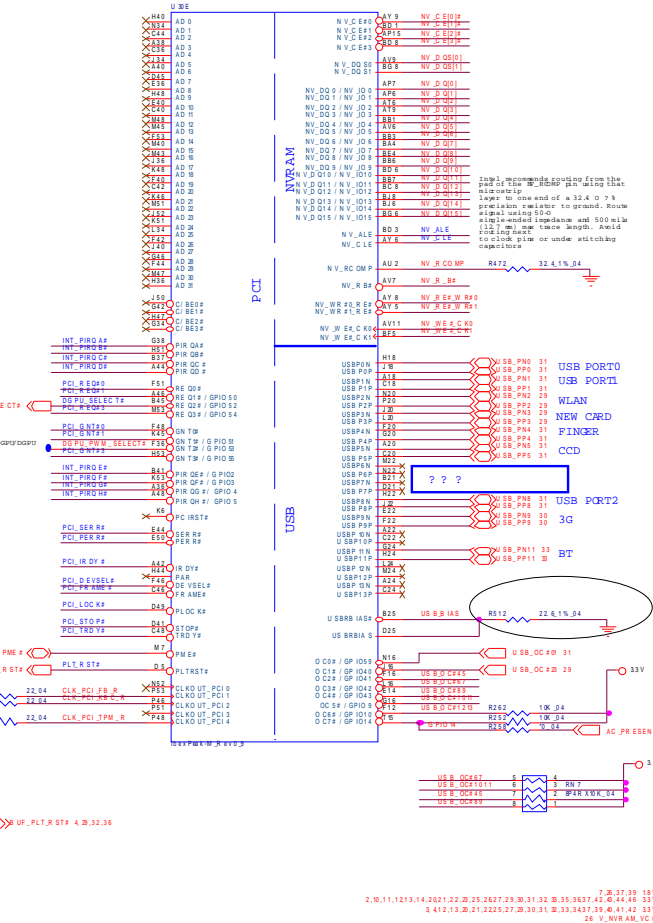
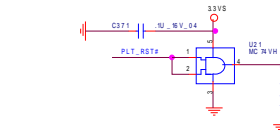
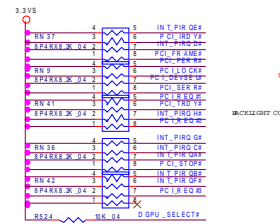
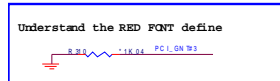

Sheet 24 of 55
IBEXPEAK - M 5/9

B.Schematic Diagrams

IBEXPEAK - M 8/9

Sheet 27 of 55
IBEXPEAK - M 8/9

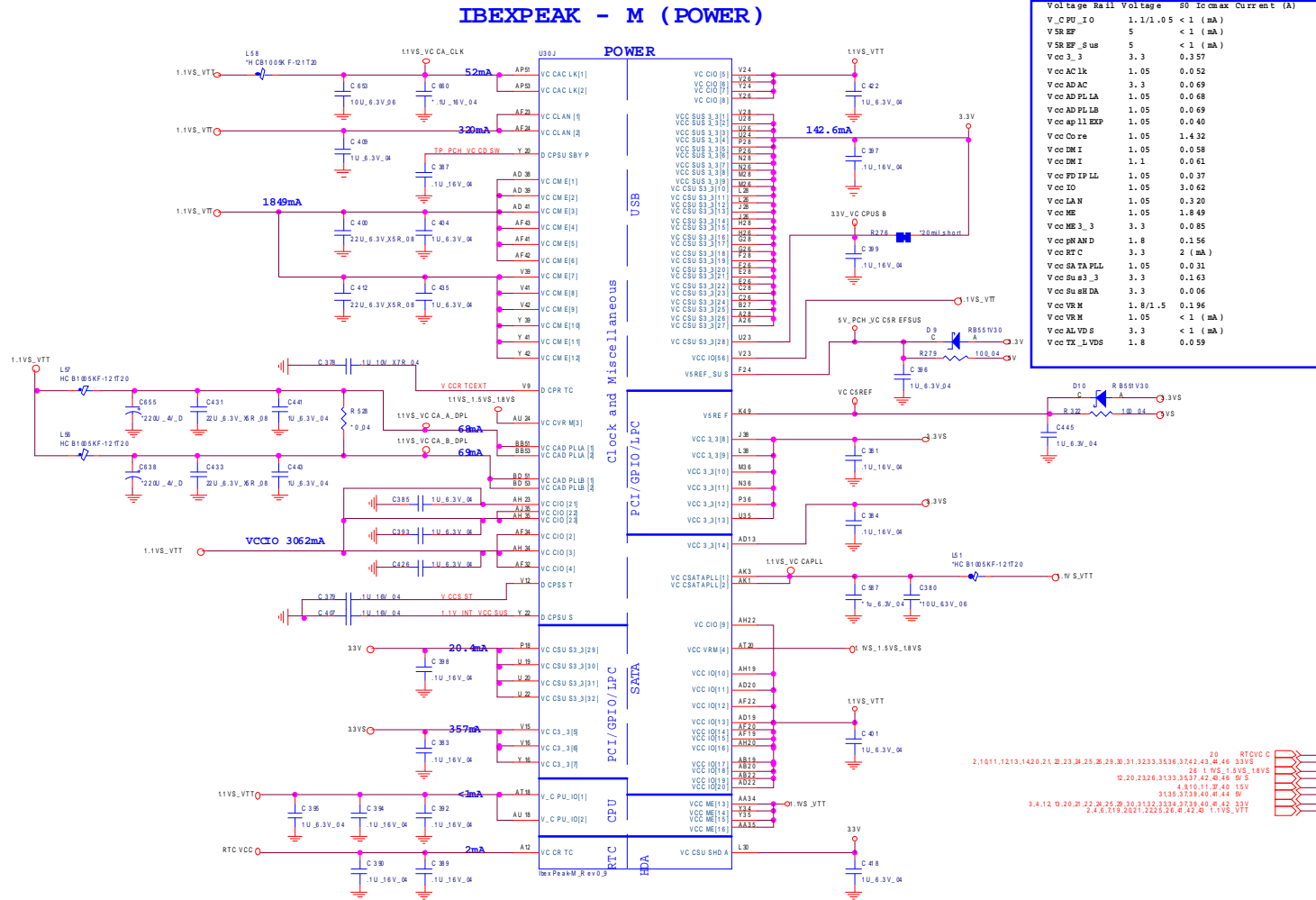

IBEXPEAK - M 9/9

IBEXPEAK - M (GND)

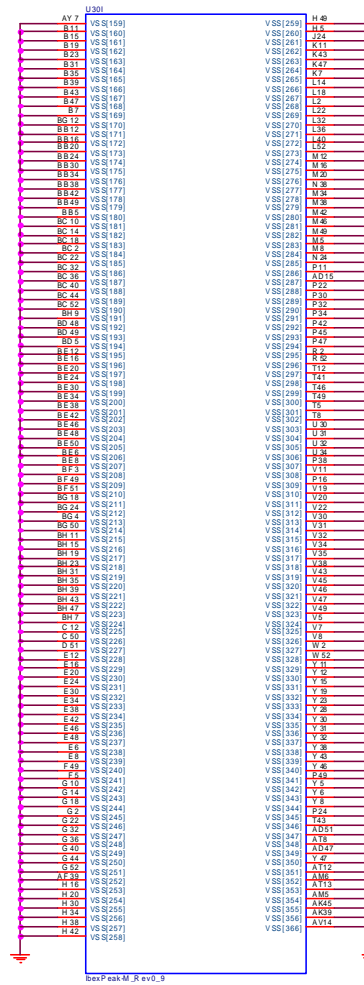
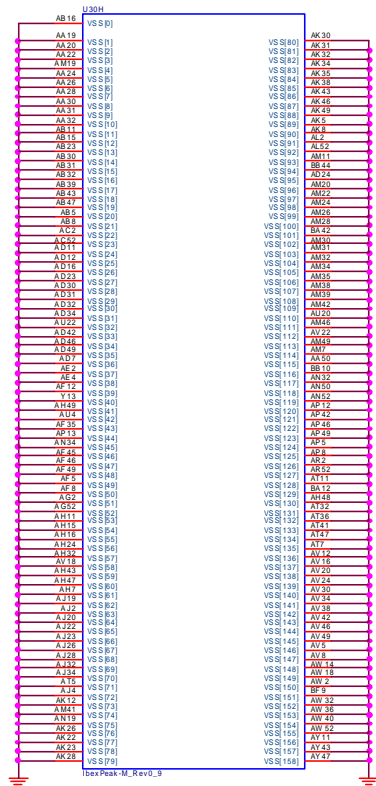

Sheet 28 of 55
IBEXPEAK - M 9/9

New Card, Mini PCIE

Sheet 29 of 55
New Card, Mini PCIE

NEW CARD

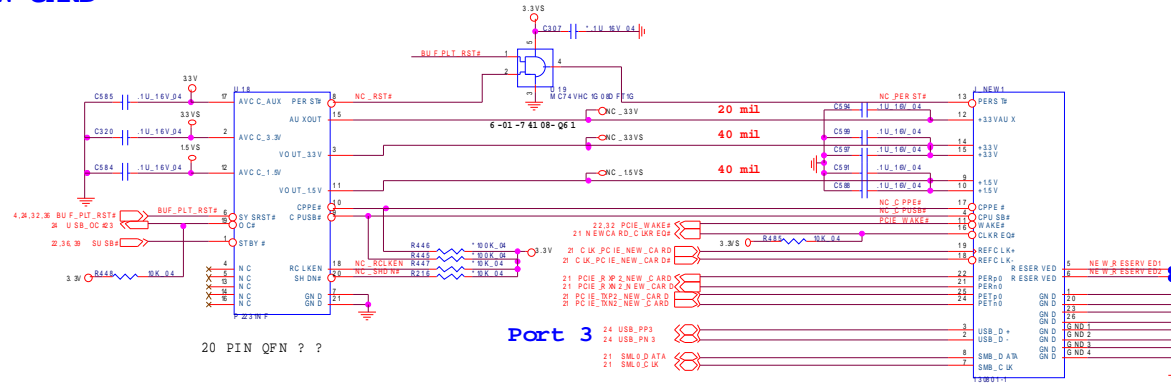

MINI CARD

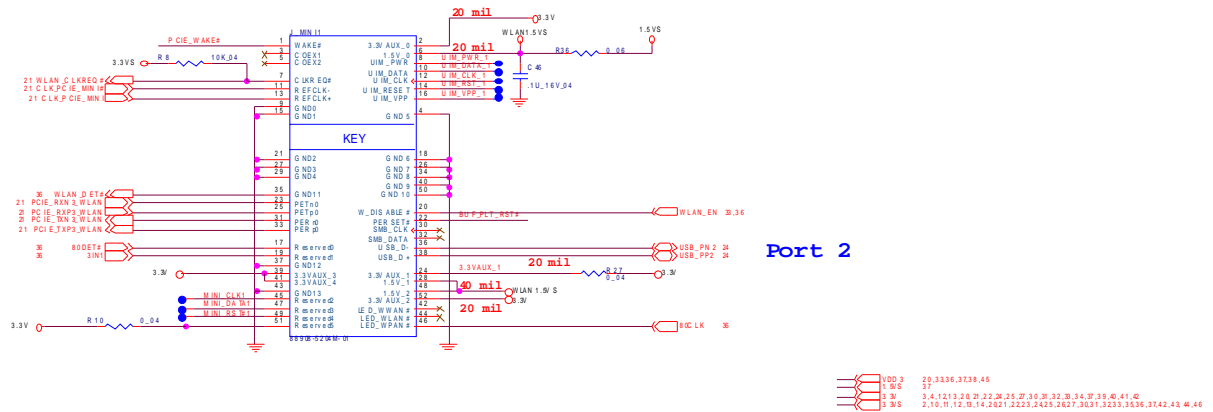

3G, TPM

3G

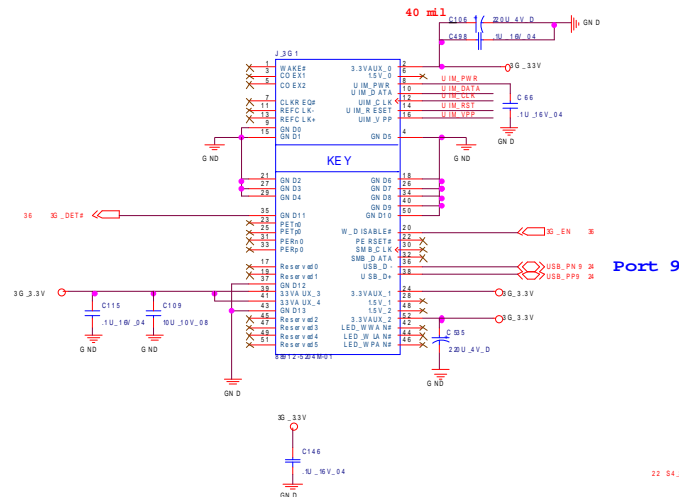

Port 9

SIM CONN

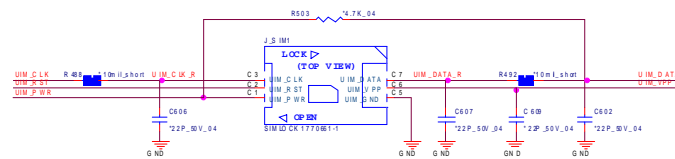

W/O 3G W/O TPM

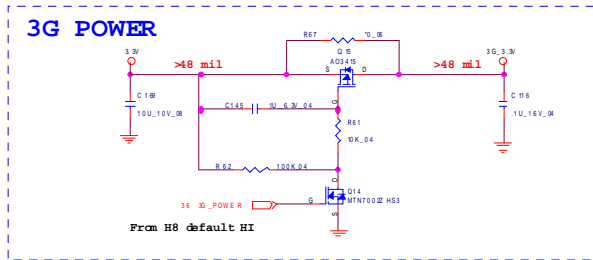

From H8 default HI

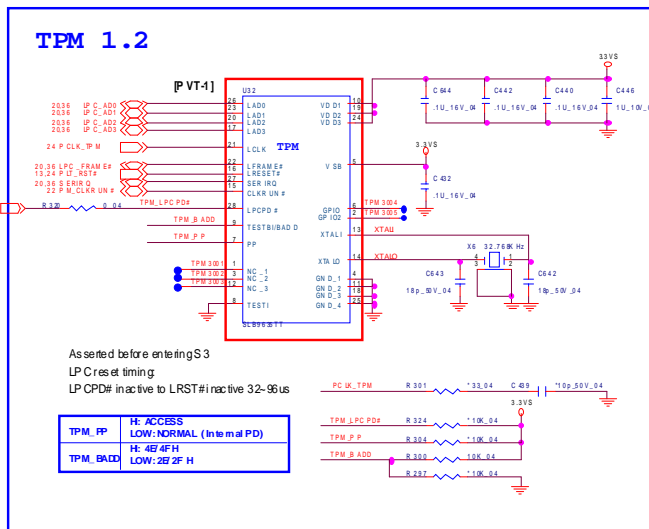

As asserted before entering S3
 LP C reset timing
 LP CPD# inactive to LRST# inactive 32-96us

TPM_PP	H: ACCESS LOW: NORMAL (Internal PD)
TPM_P_P	H: 4E/4FH LOW: 2E/2FH
TPM_B_ADD	

3.3V 3.412.13.20.21.22.24.25.2129.31.30.33.3437.39.40.41.42
 3.3V5 2.0.11.1213.14.20.21.22.24.24.2526.27.28.31.3233.35.36.37.42.40.44.44

Sheet 30 of 55
 3G, TPM

B.Schematic Diagrams

USB, Fan, TP, FP, Multi Con

USB PORT*2

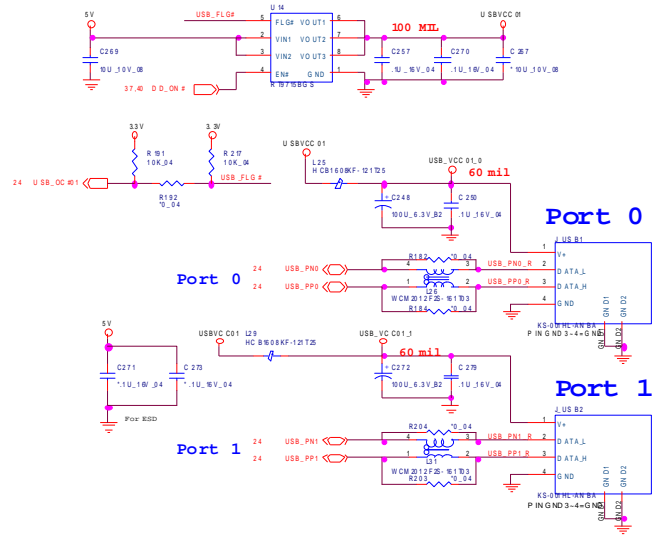

FAN CONTROL

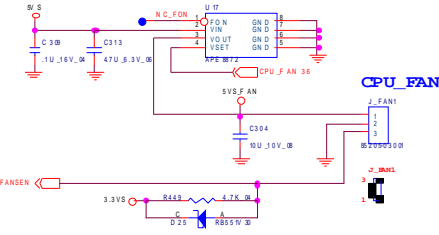

CLICK CONN FOR M760T

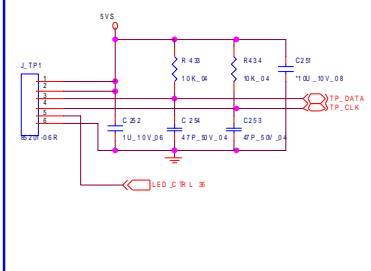

FP CONN

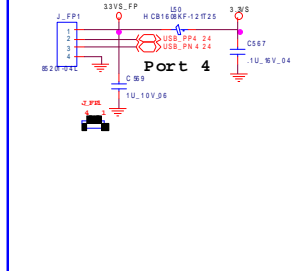

MULTI I/O CONN

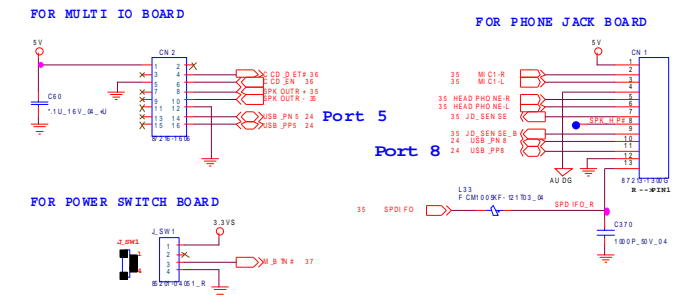

CLICK CONN FOR M740T

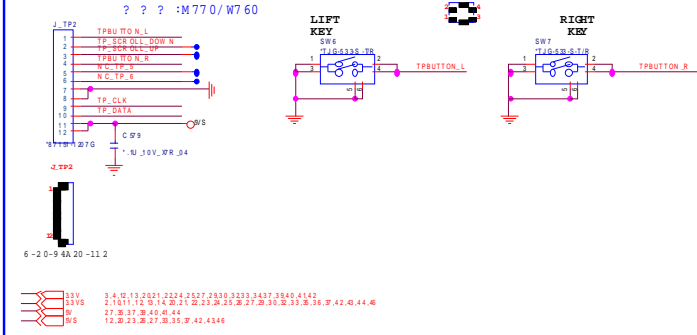

B.Schematic Diagrams

Sheet 31 of 55
USB, Fan, TP, FP,
Multi Con

SATA ODD, LED, Hotkey, LID, SW

SATA ODD

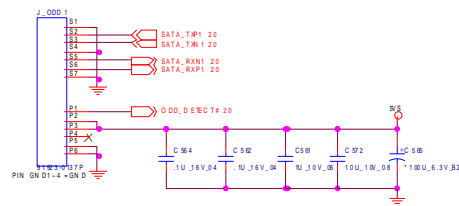

HOT KEY

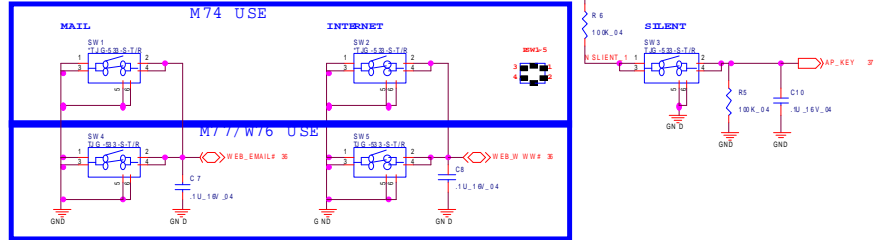

LED

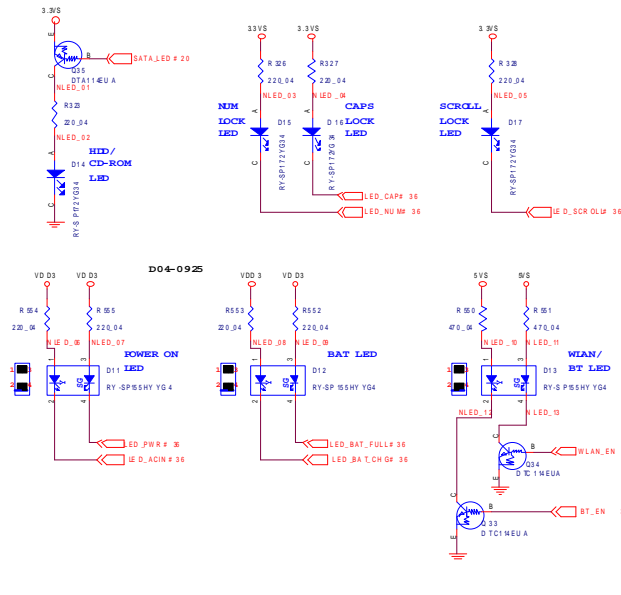

Bluetooth

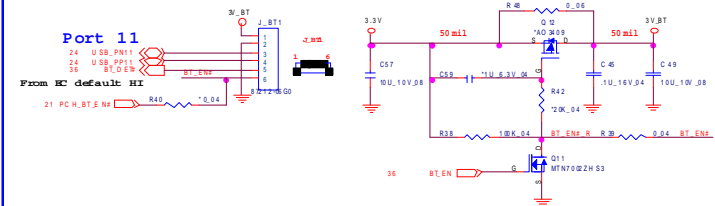

LID SWITCH IC

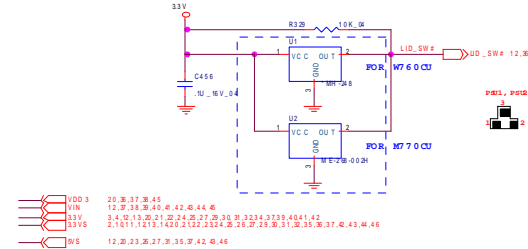

Sheet 33 of 55
SATA ODD, LED,
Hotkey, LID, SW

LAN, Modem

LAN (JMC251)

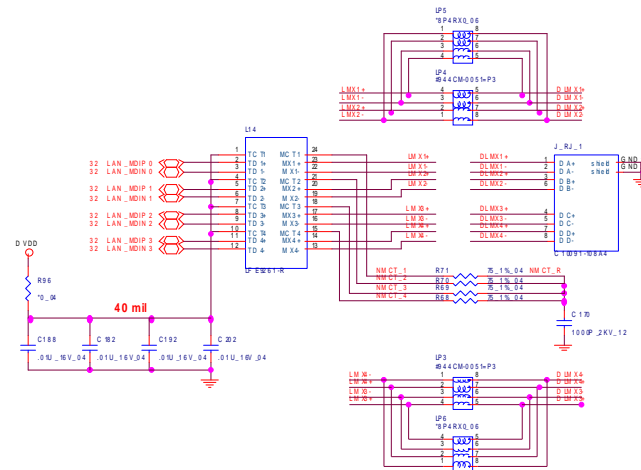

Sheet 34 of 55
Lan, Modem

B. Schematic Diagrams

MDC MODULE

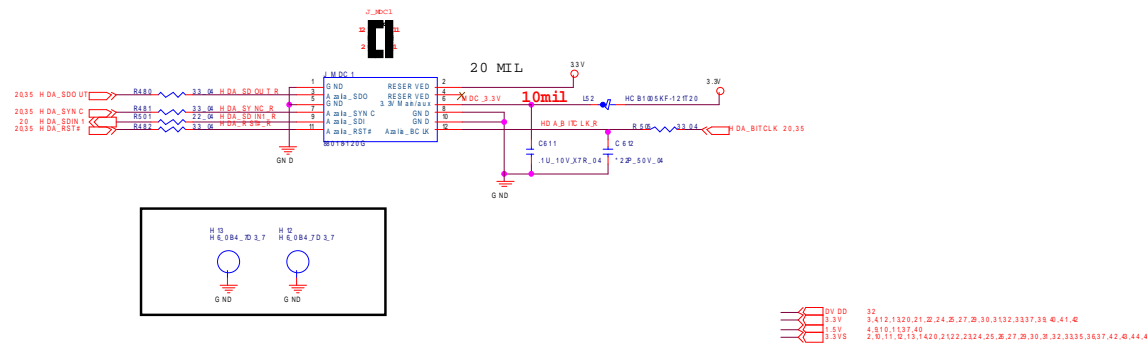

Audio Codec ALC272

CODEC (ALC272-GR)

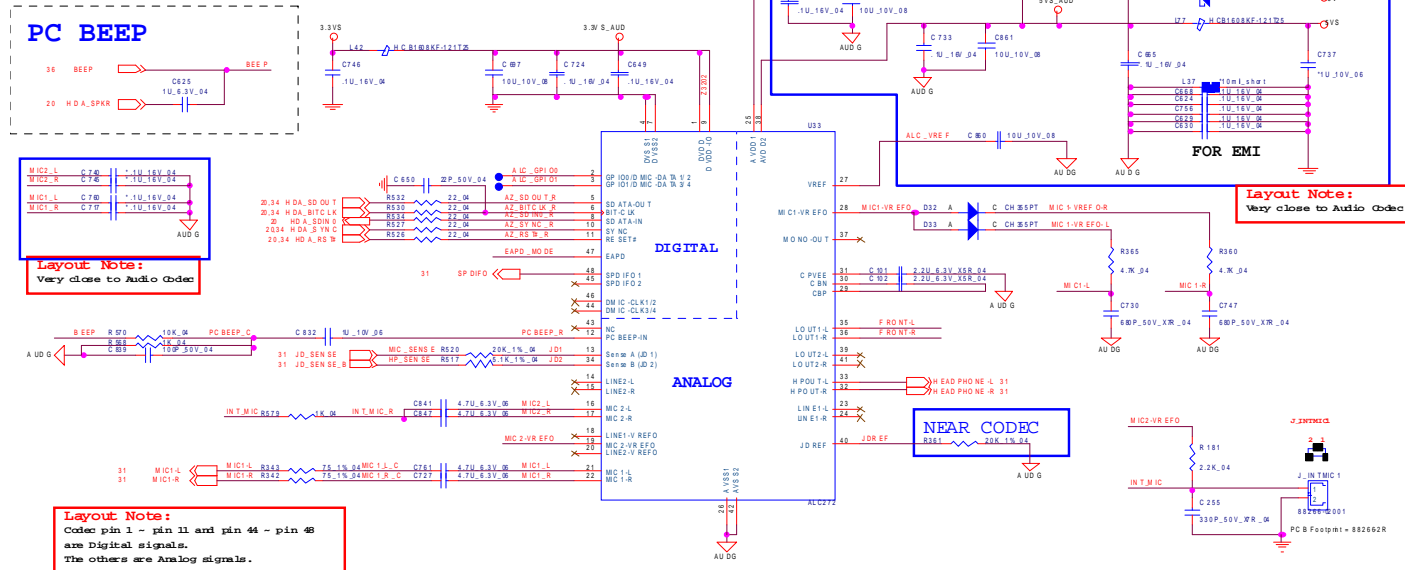

PIN 13 ,PIN34 JD_SENSE
? ? ? ? ? ? ? ?

AMP (TPA6017)

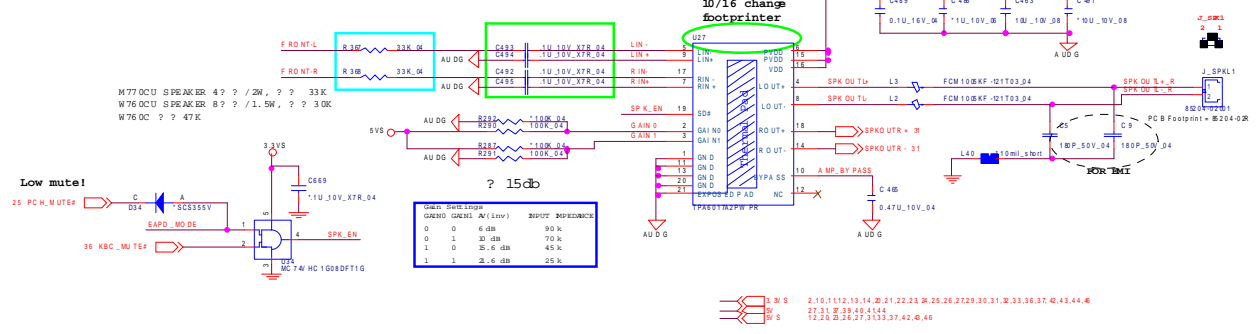

B.Schematic Diagrams

Sheet 35 of 55
Audio Codec
ALC272

KBC-ITE IT8502E

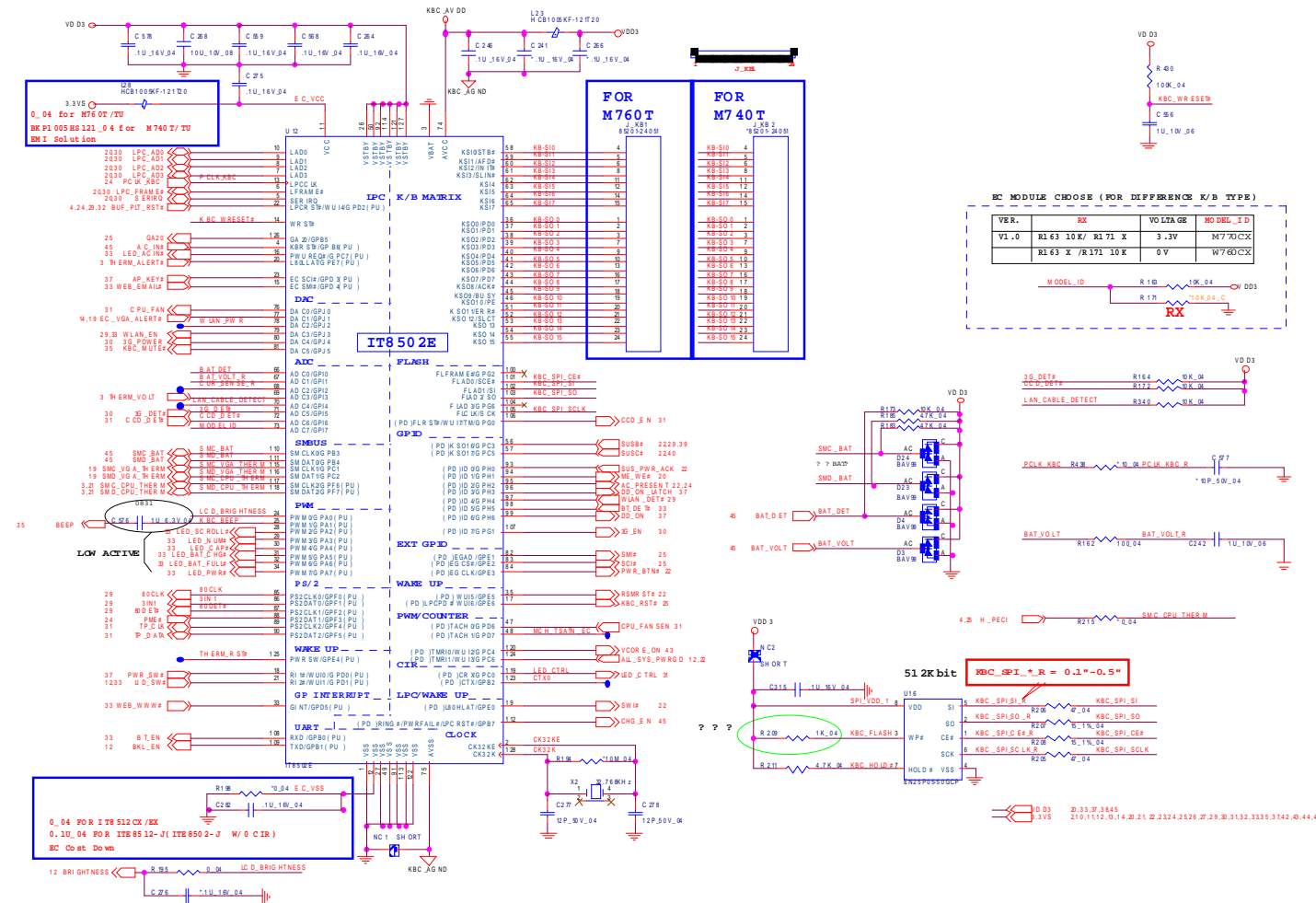

Sheet 36 of 55
KBC-ITE IT8502E

B. Schematic Diagrams

Power 3.3V/5V

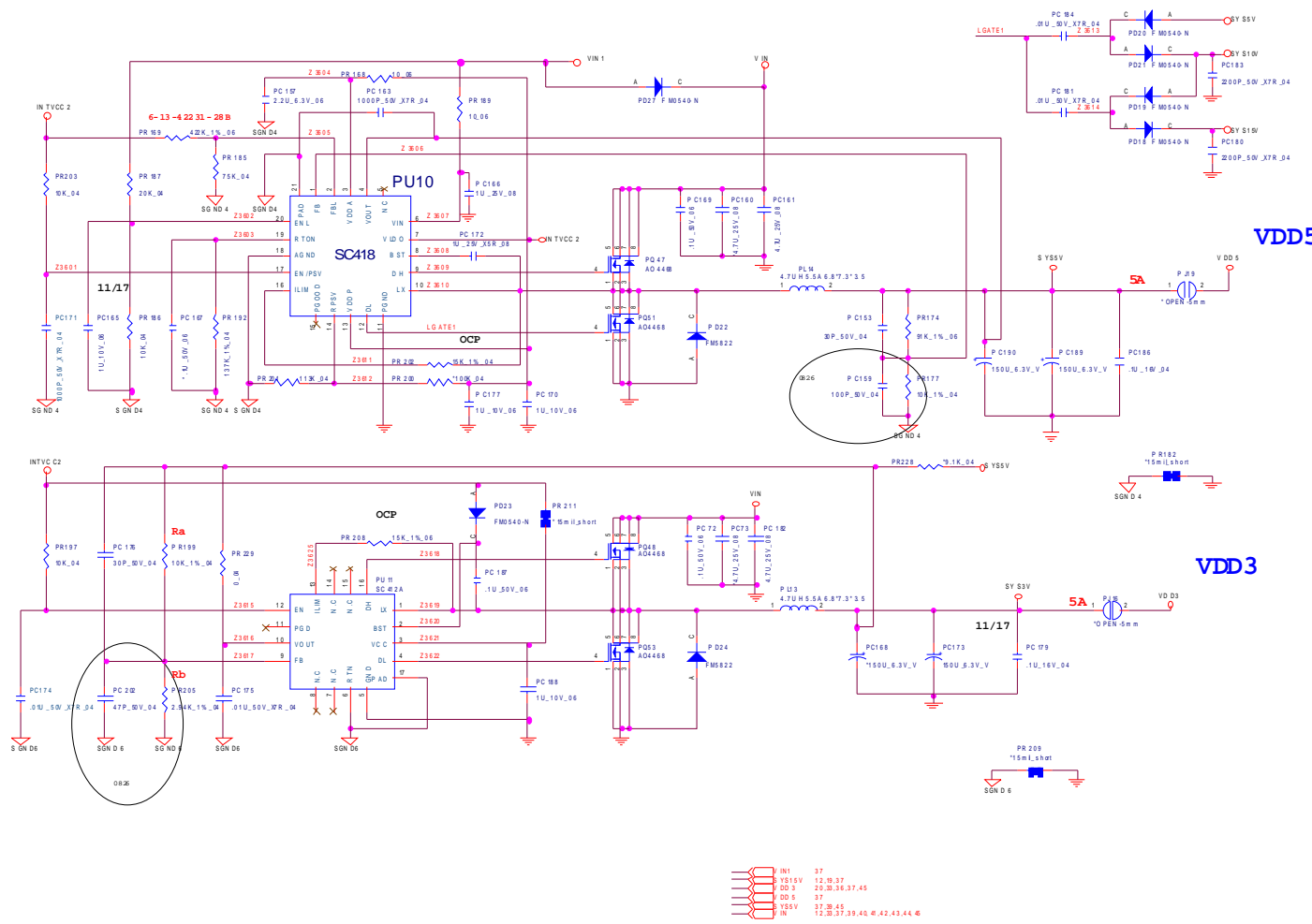

VDD5

Sheet 38 of 55
Power 3.3V/5V

VDD3

B. Schematic Diagrams

Schematic Diagrams

Power 1.8V

Sheet 39 of 55
Power 1.8V

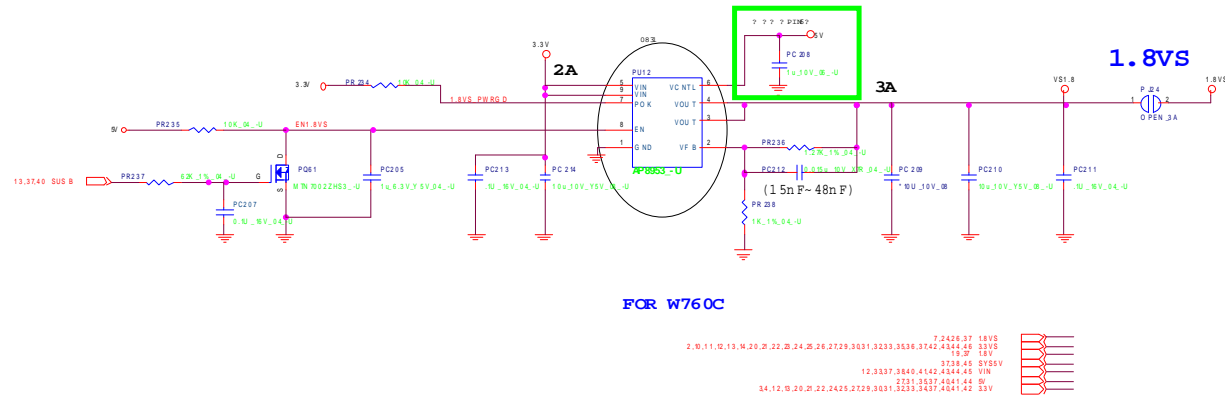
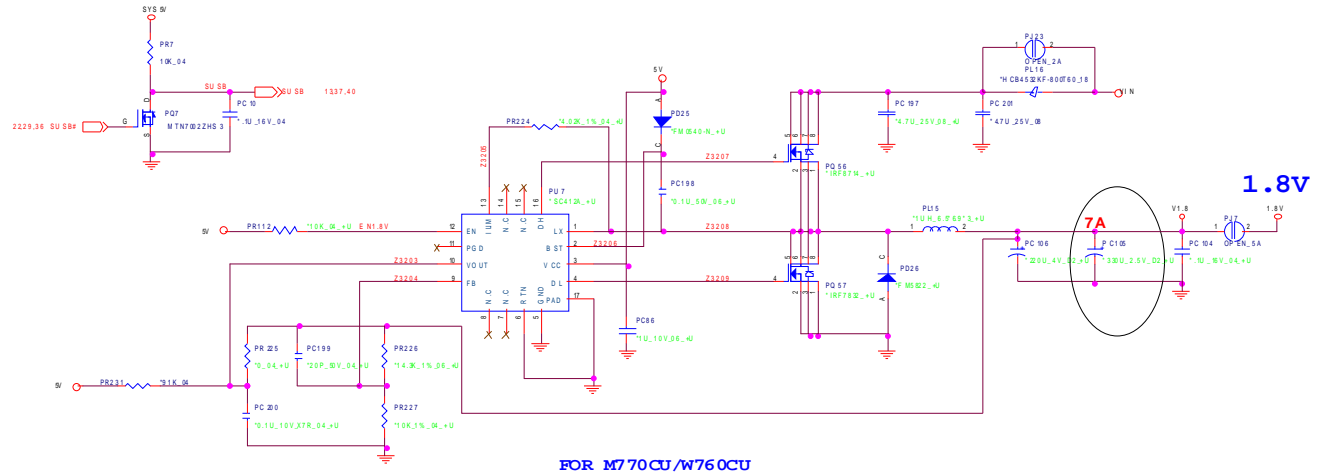

Power 1.1VS_VTT

Sheet 41 of 55
Power 1.1VS_VTT

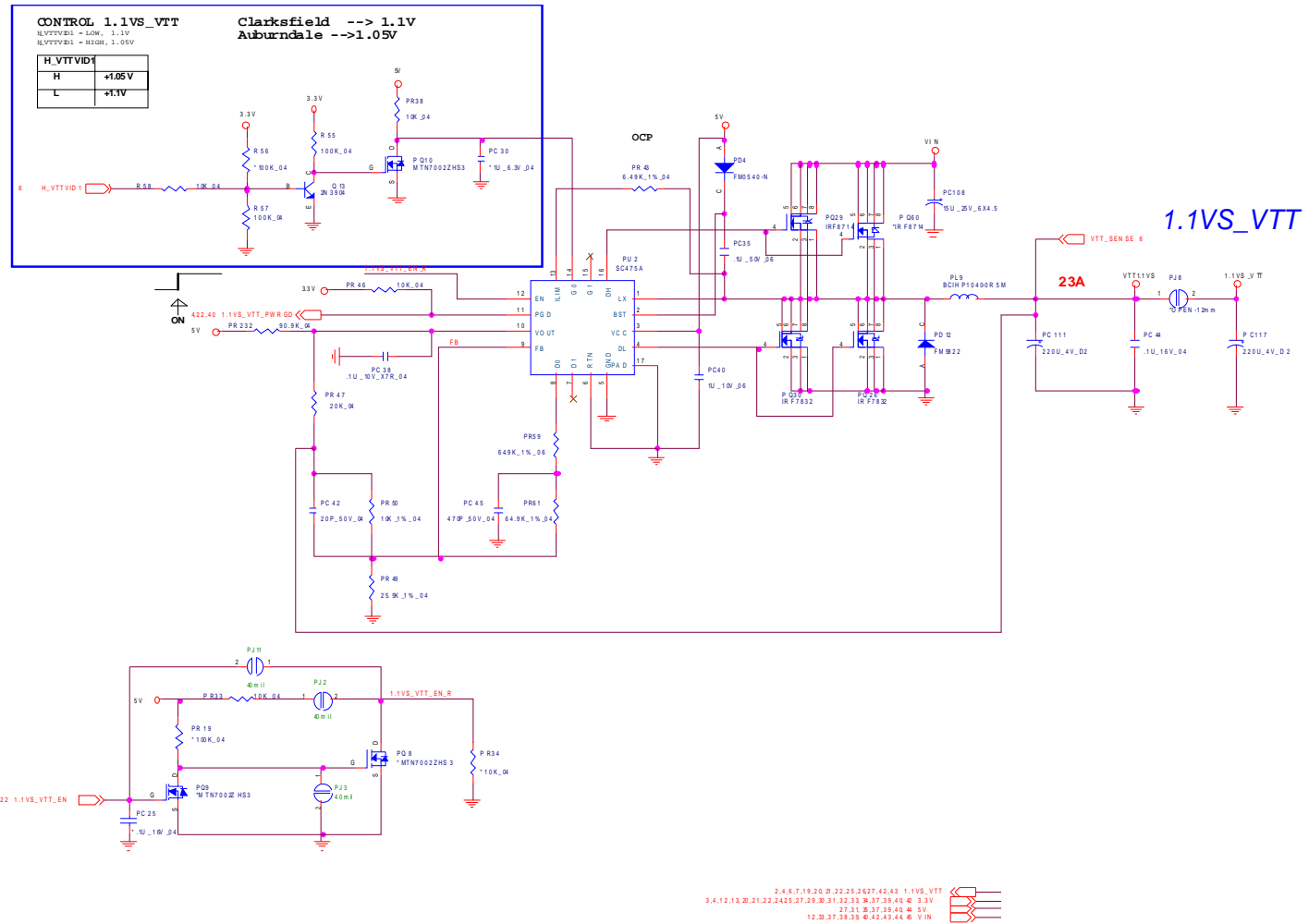

Power VGFX_CORE

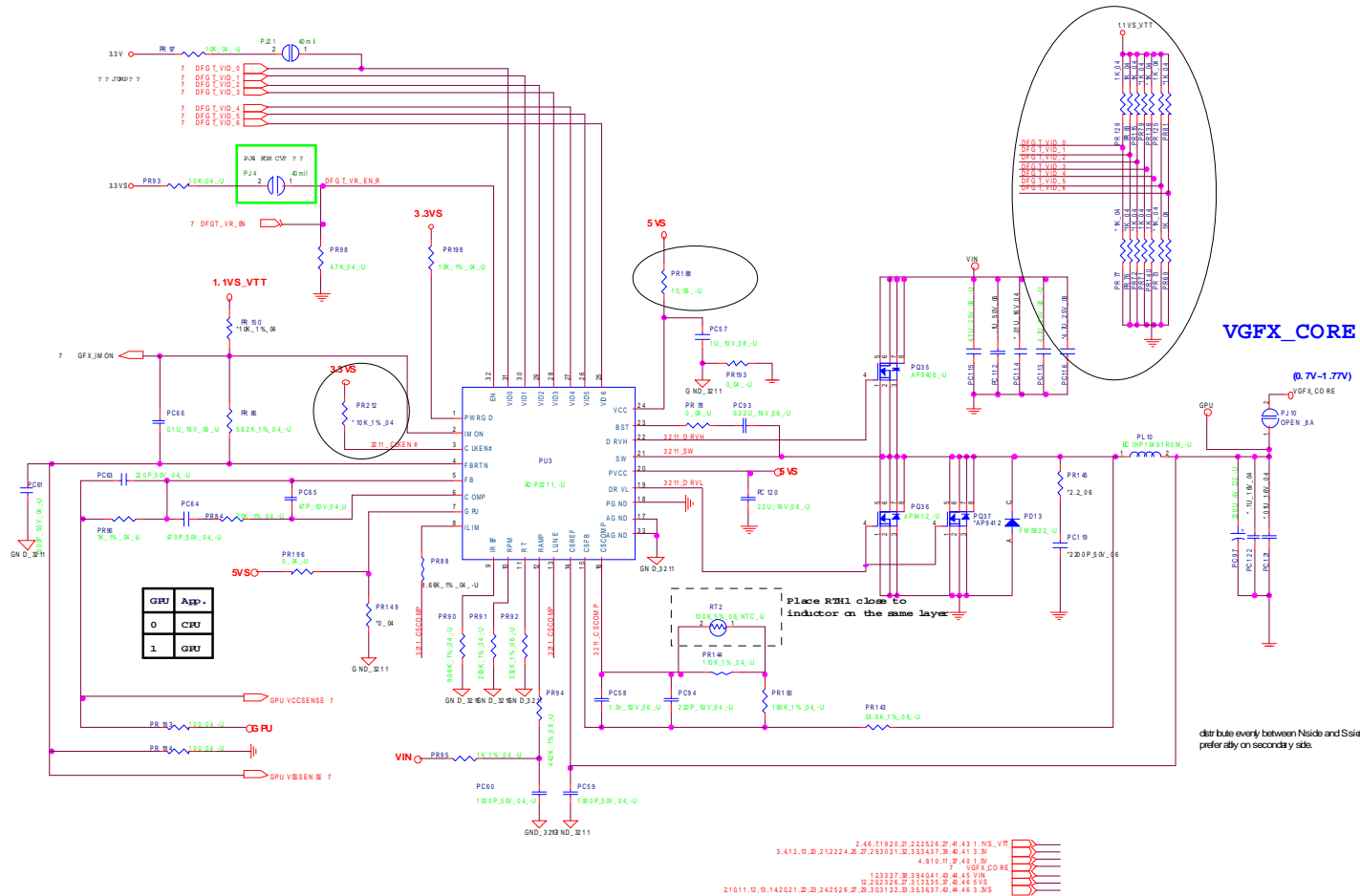

Sheet 42 of 55
Power VGFX_Core

B. Schematic Diagrams

V-Core

Sheet 43 of 55
V-Core

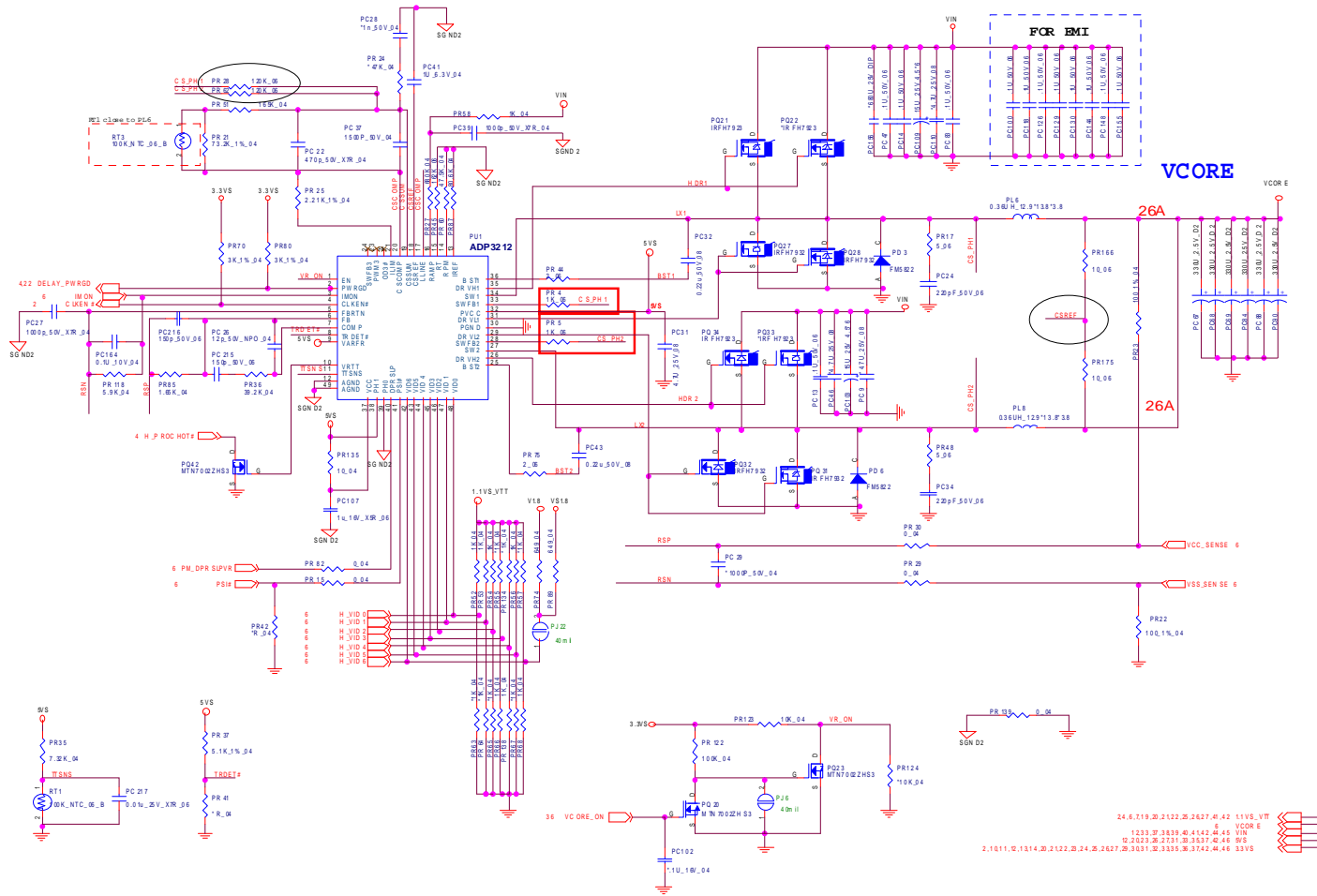

M92 VDDC

FOR ATI M92-S2 XT VGA

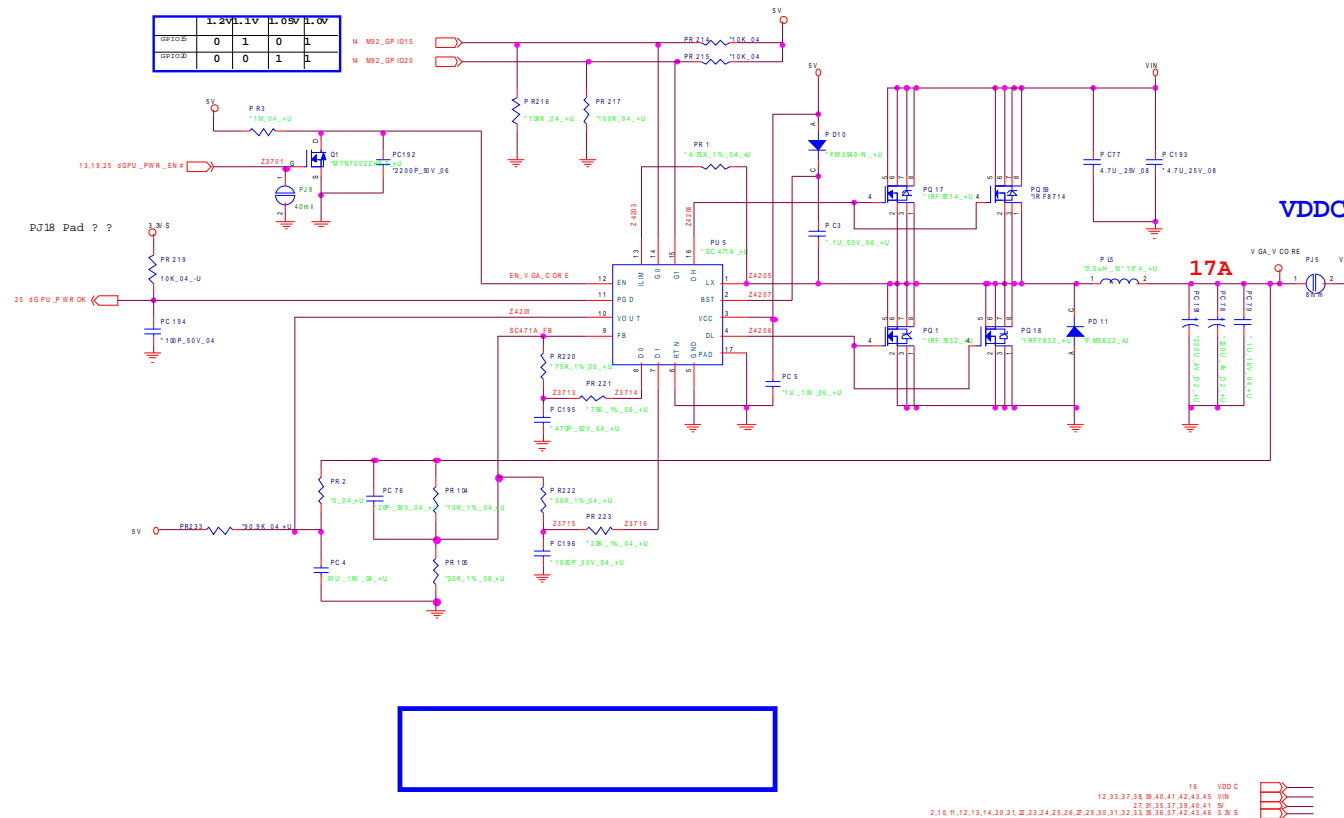

Sheet 44 of 55
M92 VDDC

B. Schematic Diagrams

AC-IN, Charger

Sheet 45 of 55
AC-IN, Charger

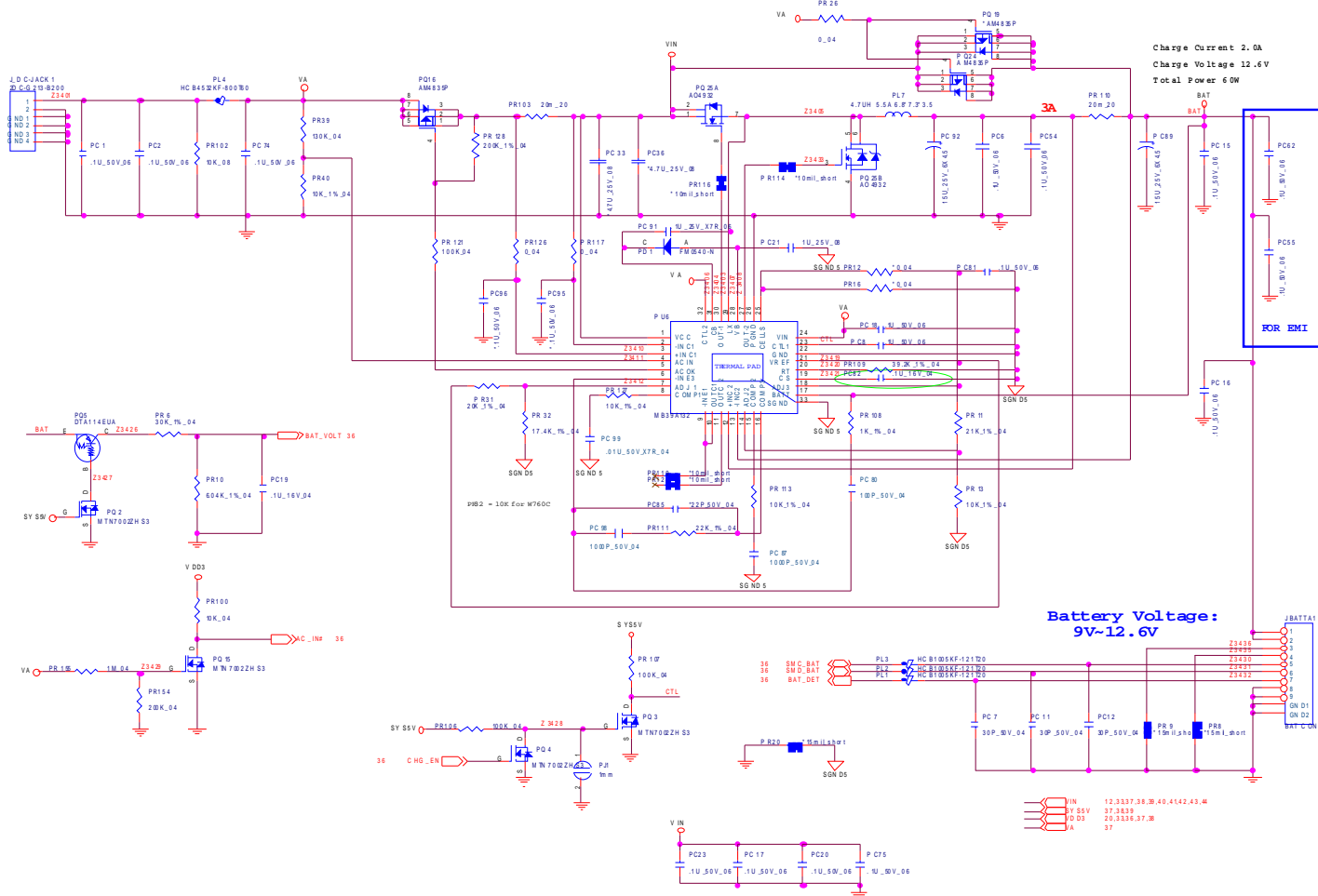

HDMI

HDMI CONNECTOR

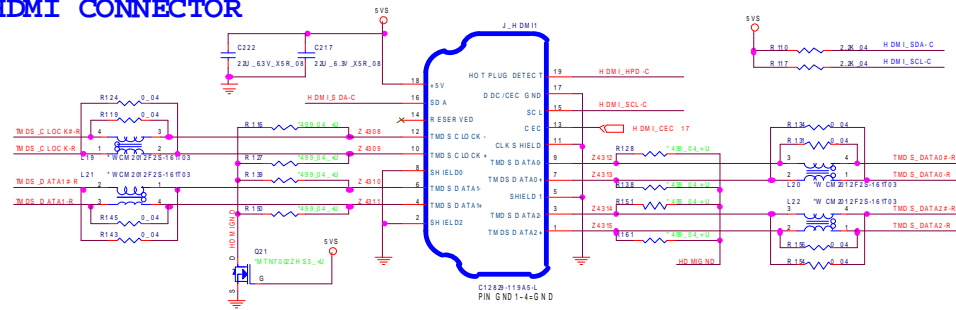

Audio Board

Sheet 47 of 55
Audio Board

USB PORT

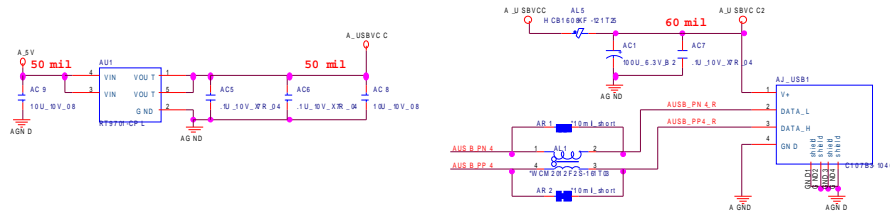

AUDIO JACK

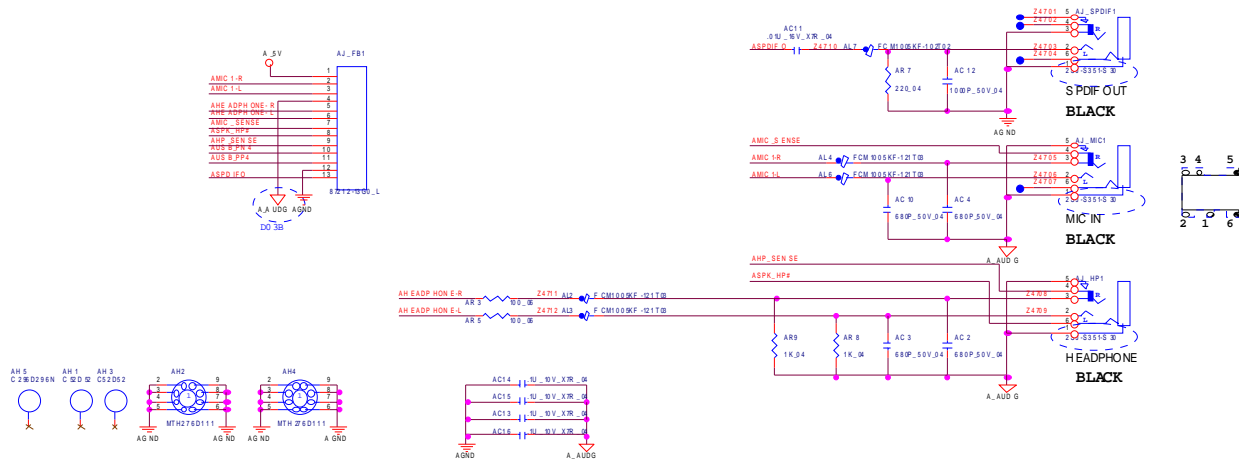

Finger Sensor Board TCS4X

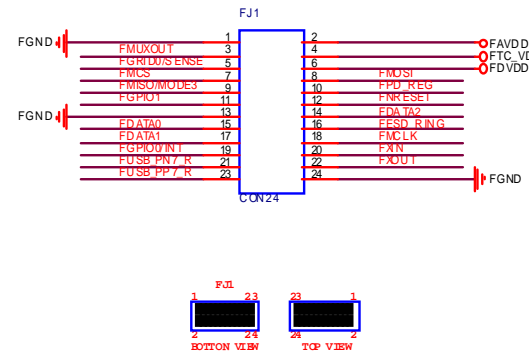
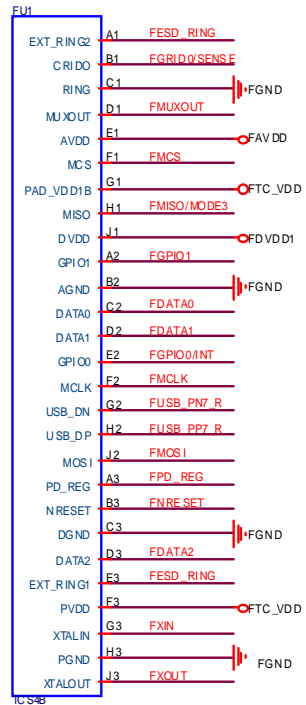

Sheet 48 of 55
Finger Sensor
Board TCS4X

Power Switch Board for M74

POWER SW & POWER LED FOR M74

Sheet 49 of 55
Power Switch
Board for M74

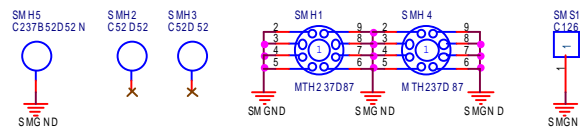
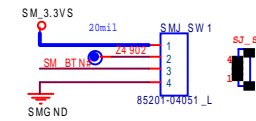
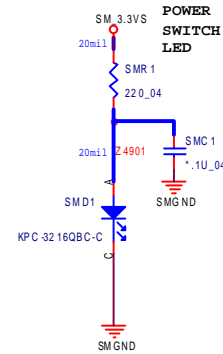
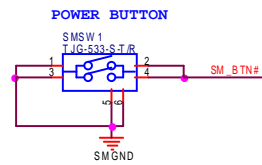

Power Switch Board for M76

POWER SW & POWER LED FOR M76

Sheet 51 of 55
Power Switch
Board for M76

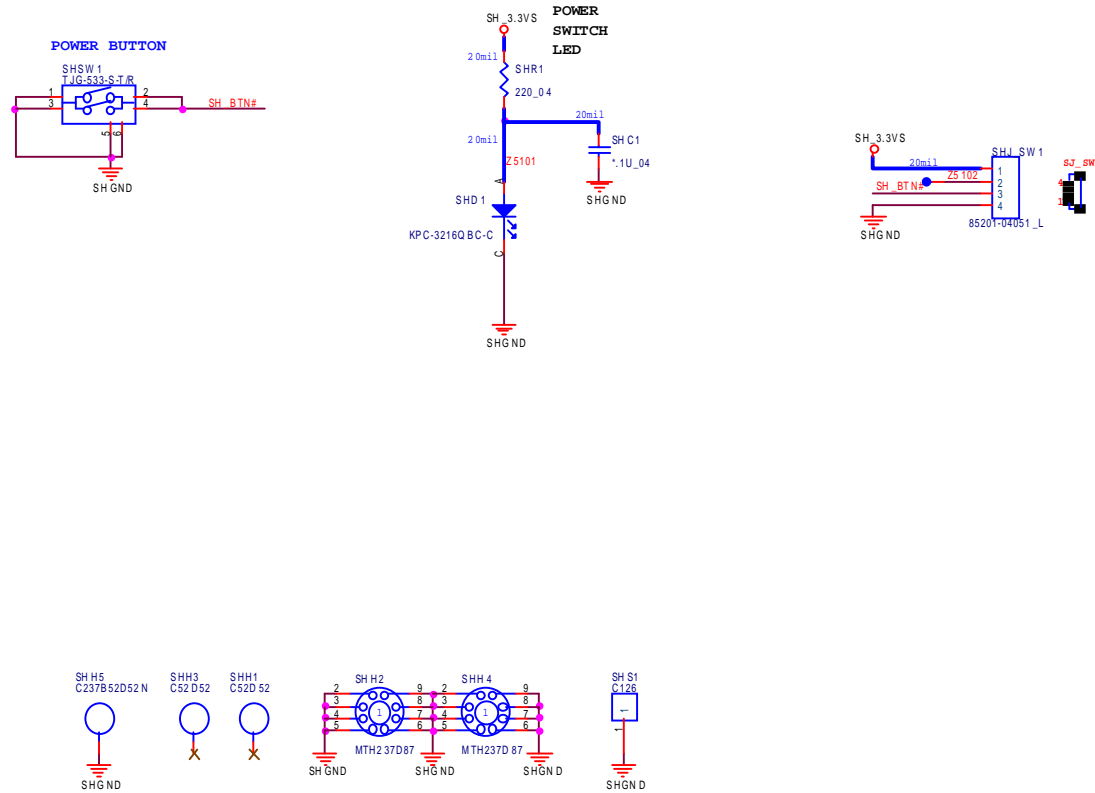

External ODD Board for W76

ODD BOARD FOR W76

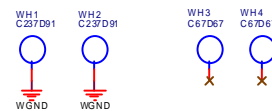
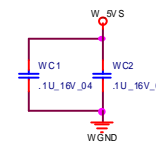
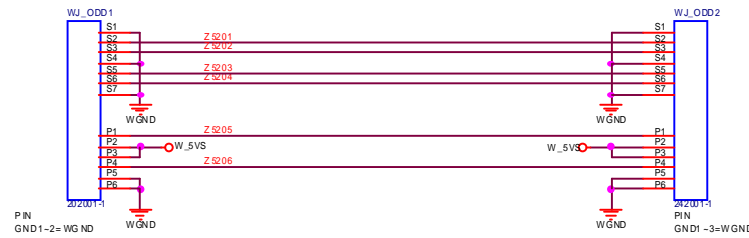

Sheet 52 of 55
External ODD
Board for W76

ODD Board for M760T

ODD BOARD

Sheet 53 of 55
ODD Board for
M760T

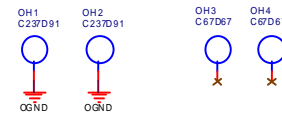
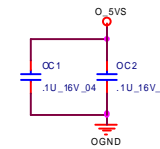
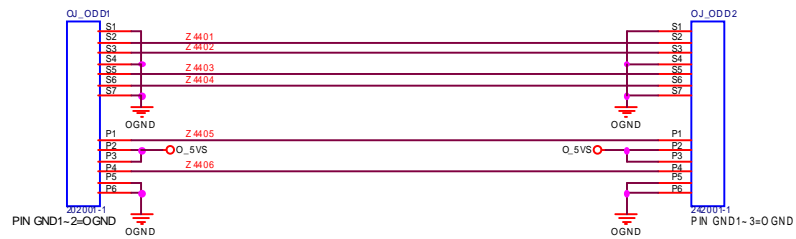

Click Finger Board for M77

CLICK BOARD

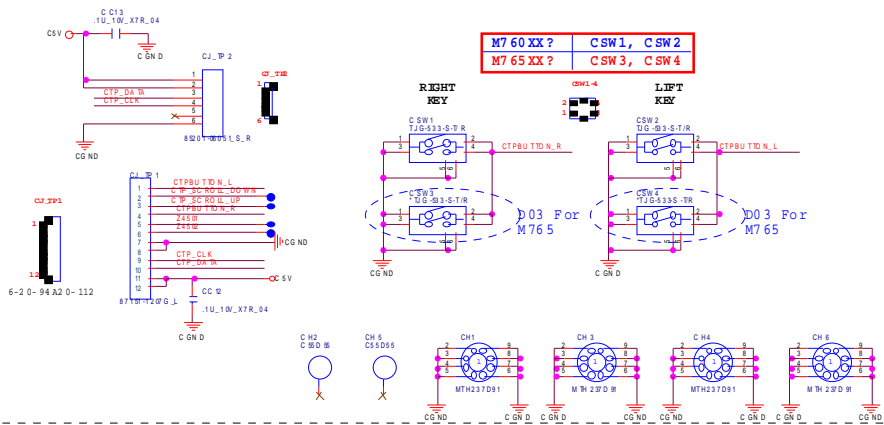

FINGER BOARD

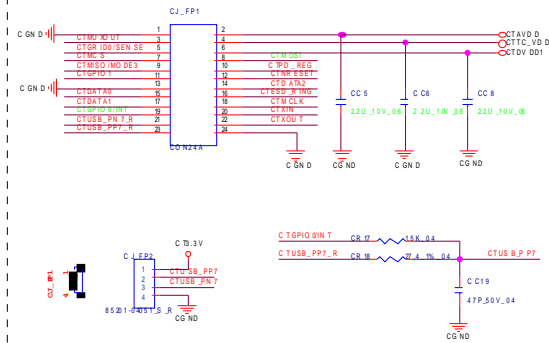

Sheet 54 of 55
Click Finger Board
for M77

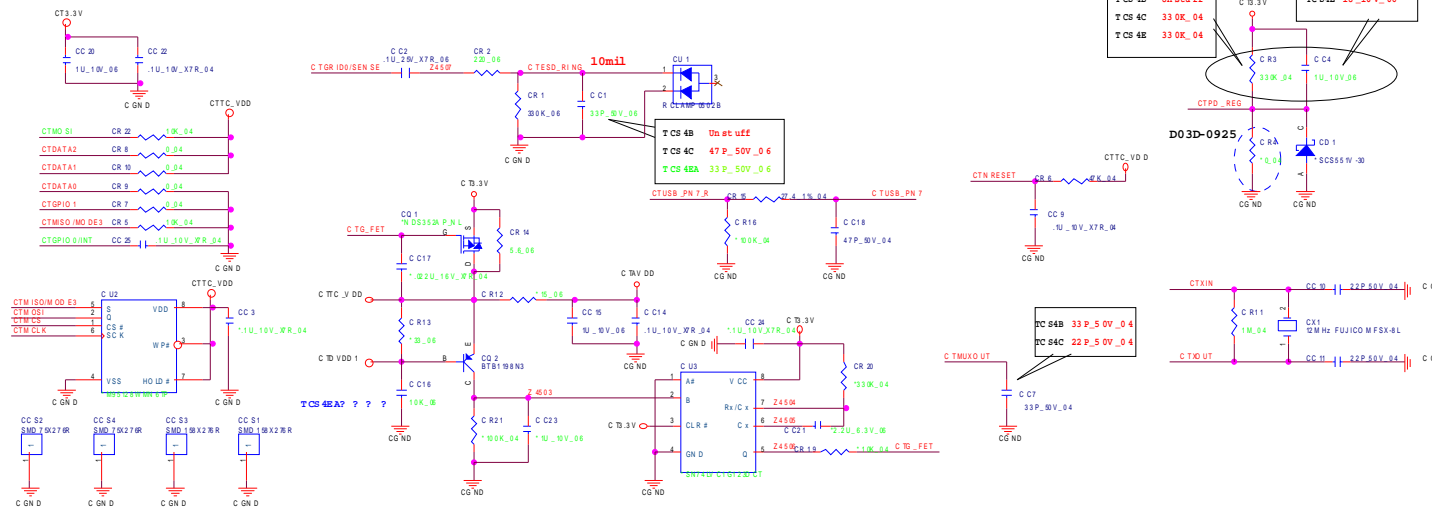

Multi Function Board

SPEAKER CONNECTOR

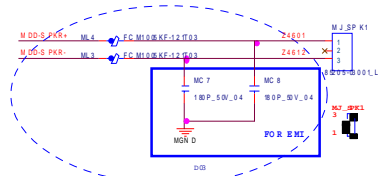

MULTI I/O CONN

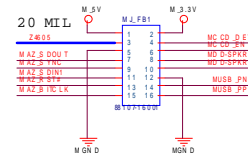

CCD

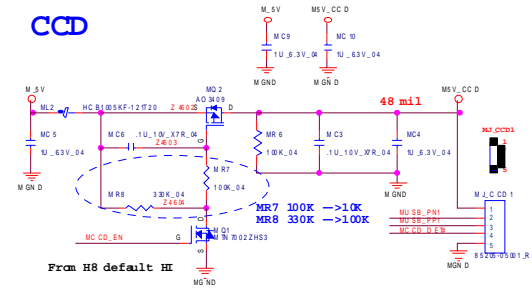

Sheet 55 of 55
Multi Function
Board

RJ-11

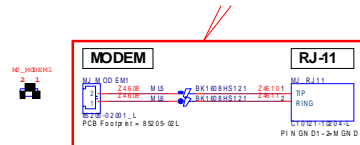

MDC MODULE

